



Ricerca di Sistema elettrico

Risultati relativi al grado di purezza del litio circolante nell'impianto Lifus 6 ed al funzionamento ed efficienza di dispositivi e procedure per la purificazione

P. Favuzza
A. Antonelli
M. Cuzzani
G. Fasano
S. Mannori

RISULTATI RELATIVI AL GRADO DI PUREZZA DEL LITIO CIRCOLANTE NELL'IMPIANTO LIFUS 6 ED AL FUNZIONAMENTO ED EFFICIENZA DI DISPOSITIVI E PROCEDURE PER LA PURIFICAZIONE

P. Favuzza	FSN-ING-QMN	Enea Firenze
A. Antonelli	FSN-ING-TESP	Enea Brasimone
M. Cuzzani	FSN-ING-TESP	Enea Brasimone
G. Fasano	FSN-ING-TESP	Enea Brasimone
S. Mannori	FSN-TECFIS-DIM	Enea Frascati

Settembre 2016

Report Ricerca di Sistema Elettrico

Accordo di Programma Ministero dello Sviluppo Economico - ENEA

Piano Annuale di Realizzazione 2015

Area: GENERAZIONE DI ENERGIA ELETTRICA CON BASSE EMISSIONI DI CARBONIO

Progetto: B.3.2 – Attività di Fisica della Fusione Complementari a ITER

Obiettivo: *B1 forniture ed implementazioni comuni per progettazione, costruzione ed operazioni riguardanti gli impianti a litio ELTL e Lifus6 per attività sperimentali su corrosione/erosione, purificazione, termoidraulica e cavitazione per IFMIF*

Responsabile del Progetto: A. Pizzuto, ENEA

Si ringraziano la dott.ssa Rita Traversi ed il dott. Mirko Severi del Dipartimento di Chimica dell'Università di Firenze per il supporto fornito nell'analisi cromatografica di soluzioni acquose di Cloruro di Ammonio.

Indice

SOMMARIO.....	4
1 INTRODUZIONE	5
2 DESCRIZIONE DELLE ATTIVITÀ SVOLTE E RISULTATI.....	7
2.1 RESISTIVITY METER (RM) FUNCTIONING.....	7
2.1.1 <i>Brief theoretical background</i>	7
2.1.2 <i>Deeper analysis of the contributions to the measured electrical resistance</i>	8
2.1.3 <i>Measurement with the Resistivity Meter filled by Lithium</i>	10
2.2 LITHIUM PURIFICATION OPERATIONS BEFORE THE START-UP OF THE EROSION-CORROSION TEST.....	12
2.3 PURIFICATION DEVICES BEHAVIOR DURING THE EROSION-CORROSION TEST	16
2.4 LITHIUM QUALITY AND PURIFICATION OPERATIONS AFTER THE FIRST EROSION-CORROSION TEST	20
2.5 OVERALL CONSIDERATIONS ON THE HOT TRAP EFFICIENCY	23
3 CONCLUSIONI.....	25
4 RIFERIMENTI BIBLIOGRAFICI	26
5 ABBREVIAZIONI ED ACRONIMI.....	27

Sommario

This report deals with the monitoring of the purity of Lithium flowing through Lifus 6 plant, a plant realized during the previous years in ENEA Brasimone centre in order to perform erosion-corrosion resistance tests of steels specimens, when exposed to flowing liquid Lithium at 330°C. Lithium purity and particularly very low concentrations of non metallic elements in Lithium is in fact mandatory for the execution of these tests, since non metals presence strongly enhances the corrosive behavior of the alkaline metal itself. For this reason, Lifus 6 plant was equipped with devices and solutions aimed both at monitoring Lithium purity during the experimentation, both at reducing, when necessary, the impurities below the admitted maximum values.

While during the last year Lithium purity was checked and confirmed during the commissioning of the plant, in this year it was monitored during the execution of the real erosion-corrosion tests, to guarantee the keeping of the test purity requirement, at the same time allowing to characterize the functioning of the purification devices and their efficiency.

In particular, this report presents a deeper characterization of the functioning of the Resistivity Meter, explaining how it is possible to get a more precise correlation between the measured Lithium electrical resistance and its overall impurities content and highlighting the good agreement between theoretical previsions and measured values; shows the trend of the main plant purification parameters (Cold Trap and Resistivity Meter temperatures, electrical resistance, flow rate in the purification pipe) during Lifus 6 experimental test, highlighting how they are intimately related; presents the results of Nitrogen concentration during the 2 performed erosion-corrosion test (the Short and the Mid Term Test: on the whole, about 3200 hours of experiment), as got from the dedicate offline chemical analysis of sampled Lithium; shows the ability of the Hot Trap, operated in the range 550-600°C, to significantly remove Nitrogen from Lithium, permitting it to comply with the test requirement (≤ 30 wppm) and promoting the Titanium sponge as a promising getter for future Lithium applications.

On the basis of all the presented results, Lifus 6 purification system was proven to satisfy very fine its task.

1 Introduzione

Lifus 6 plant was designed and constructed by ENEA during 2011-2014 in its research centre of Brasimone, in order to experimentally assess the resistance of Reduced Activation Ferritic-Martensitic (RAFM) steels to the erosion-corrosion mechanism exerted by flowing liquid Lithium: this investigation constitutes one of the validation activities underlying the future IFMIF facility (EVEDA phase of the IFMIF project, which is part of the Broader Approach). The main test operative conditions were defined as: Lithium linear speed in the Test Section (where it contacts the specimens) = 15 m/s; Lithium temperature = 330°C¹; Carbon (C) and Oxygen (O) concentration in Lithium ≤ 10 wppm; Nitrogen (N) concentration ≤ 30 wppm; Hydrogen (H) concentration ≤ 60 wppm.

The purity level of Lithium flowing inside the plant is hence a fundamental aspect to take into account: it is known in fact that the presence of non metals, like C, O, H and particularly N, in the form of anions solved by liquid Lithium, greatly enhances the chemical corrosion mechanisms affecting the steels [1,2]. Lithium purification is therefore mandatory and for this reason a specific IFMIF task (LF04-EU Procurement Arrangement) has been dedicated to its aspects. The fulfillment of this task has led, during the previous years to the implementation of specific procedures for the purification of Lithium and for the quantification of Nitrogen concentration in Lithium, as described in Rds/2013/125 [3], Rds/2013/126 [4] and Rds/2013/209 [5].

A summary of the Lifus 6 devices and solutions adopted for the purification purpose is reported in Table 1. A Cold Trap, operated at 200°C, removes C and O from Lithium and lowers H and N content too; an Hot Trap, operated at 550°C-650°C, is employed for the further reduction of N concentration to the target value of 30 wppm; a Resistivity Meter (RM), providing an online value of the Lithium electrical resistance, permits to gain info about the total impurities content; two samplers (small detachable containers, in two different positions of the plant), allow to take a minimal Lithium mass from the plant and to determine N concentration in it, after a specific chemical analysis procedure.

Table 1: main features of Lifus 6 purification elements (C_x = weight concentration of X element in Li)

Purification Element	Function	Note
Cold Trap (CT)	Reduces non metals impurities precipitating them at ~ 200°C as solid Lithium compounds.	It works continuously during operations. At 200°C: $C_C \leq 2$ wppm; $C_O \leq 7$ wppm; $C_H \leq 63$ wppm; $C_N \leq 1461$ wppm [6]
Hot Trap (HT)	Further reduces N concentration through the adsorption by the Titanium getter.	It works in static condition on the whole Lithium, at the beginning of the operation and whenever necessary.
Resistivity Meter (RM)	Continuously (online output) indicates total impurities concentration variation.	Particularly sensitive to H e N atoms, but with high uncertainty in the absolute value.
Sampler 1	Takes a Lithium sample (~25 mL) from the purification loop, during operations.	For the Nitrogen evaluation through the chemical analysis (accuracy: a few %).
Sampler 2	Takes a Lithium sample (~25 mL) from the Hot Trap, just after a purification step.	As above.

¹ This value, originally 350°C, was lowered to 330°C by the amended LF03 Procurement Arrangement.

In order to optimize the functioning of the many purification elements, Lifus 6 plant is composed of a main loop and a secondary loop, also called “purification loop”, which works in parallel with the main one. The purification loop hosts the Cold Trap, the Resistivity Meter and a sampler (1) for the offline Lithium analysis; the Hot Trap is instead outside Lifus 6 loop, being linked only to the Lithium storage tank, from which the main loop is charged and discharged; the second sampling point for the offline analysis is connected directly to the Hot Trap. The schematic Lifus 6 block diagram (Figure 1) highlights, for ease of clarity, the relative positions of the purification system components of the plant. The implemented Lifus 6 purification loop (before the thermal insulation) is instead shown in Figure 2. More details about the purification system components design and functioning can be found in [7] and [8].

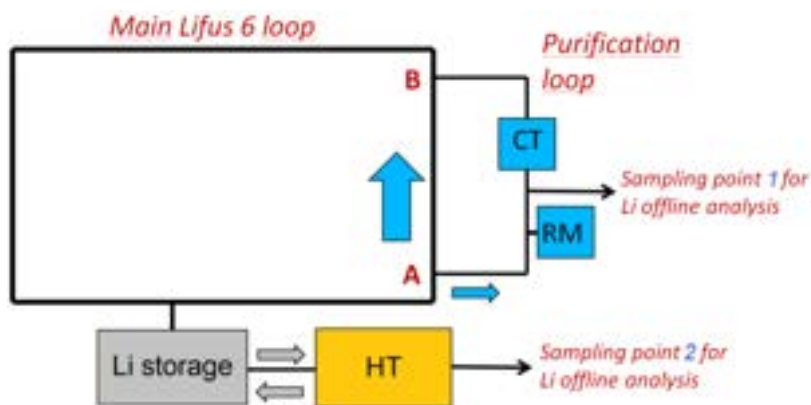

Figure 1: Block diagram of Lifus 6 purification system components. CT = Cold Trap; HT = Hot Trap; RM = Resistivity Meter. Arrows: Lithium flow directions

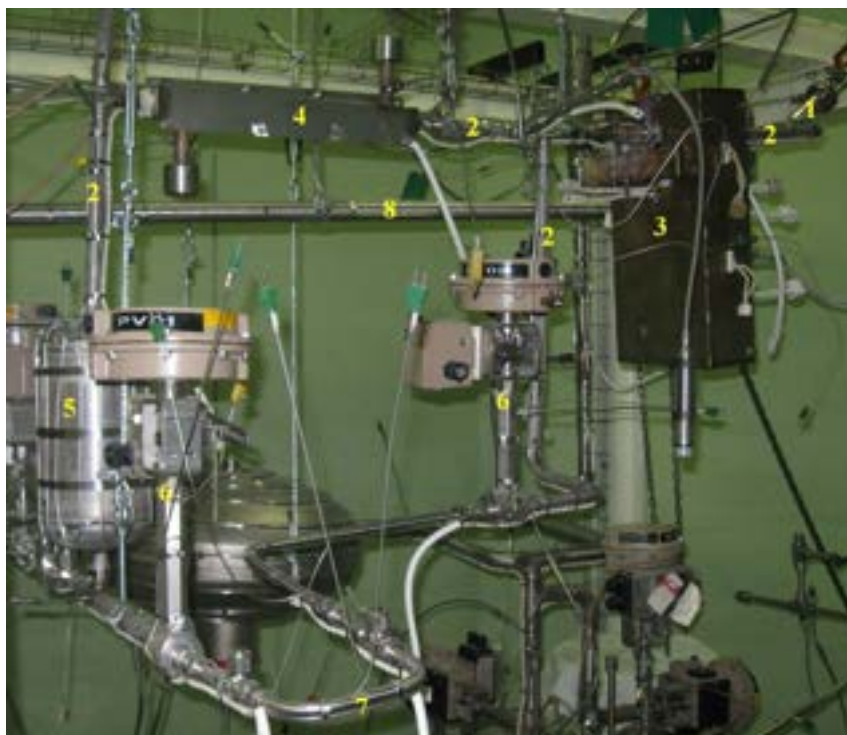

Figure 2: Overview of the purification loop. 1: regulating valve (connection to the main loop); 2: purification loop pipe; 3: Resistivity Meter; 4: Air cooler upstream of the Cold Trap; 5: Cold Trap; 6: pneumatic valves to permit/exclude Lithium circulation in the sampling tube; 7: Sampling “U” tube (Sampler 1); 8: pipeline of the main Lifus 6 loop (behind purification pipe, in the figure)

This report will present the results of Lithium purity achieved with the abovementioned solutions. Moreover, it will describe the behavior of the main purification elements during the execution of the erosion-corrosion test, providing a conclusive view on their advantages, limits and efficiency.

2 Descrizione delle attività svolte e risultati

2.1 Resistivity Meter (RM) functioning

The evolution of the status of Lithium circulating inside Lifus 6 plant can be monitored through the acquisition during time of the electrical resistance values of the metal. Below are summarized the main observations about the functioning of the Resistivity Meter, which follow from the ENEA experimentation performed during last year.

2.1.1 Brief theoretical background

The employment of the RM (shown in Figure 3 prior of its installation inside Lifus 6 plant) is based on the existence of an increasing trend of Lithium electrical resistivity (ρ_{Li}) with the impurities concentrations. Moreover, as reported by the University of Nottingham [9] for solutions of Nitrogen in liquid Lithium in the temperature range 200°-450°C, the resistivity-composition isotherms are characterized by a linear trend in a specific concentration range.

Of course, also temperature is an important parameter affecting the resistance value: for pure liquid Lithium, the following experimental relation was derived [10]:

$$\rho_{Li} [\Omega m] = 16.476 \times 10^{-8} + 4.303 \times 10^{-10} (T/^\circ C) - 2.297 \times 10^{-13} (T/^\circ C)^2 \quad (1)$$

Temperature variations may hence originate resistance variations which override variations due instead to variations in impurities concentrations, that is the information the RM is actually requested to lead to. Therefore, in order to get useful info about the Lithium purity, the temperature stability must be verified and guaranteed.

The functioning of the Resistivity Meter is monitored during time through the acquisition of 4 different temperature signals (each one related to a different Pt-100 sensor, installed along the RM capillary tube) and the electrical resistance signal, provided by the nano-ohm meter, joined to the RM electrodes. The 'RM temperature' is taken as the average of these 4 Pt-100 values, which are anyway close each other. The frequency of acquisition of all the signals is 1 Hz. In [8] it was shown that the maximum temperature oscillation for each Pt-100 sensors results $\leq 0.1^\circ C$ (in absolute value). From a theoretical point of view, taking into account the above equation and that the working temperature is $\sim 330^\circ C$, $0.1^\circ C$ translates into a resistance variation of $\sim 0.028 \text{ n}\Omega \text{ m}$, which, in turn, considering table 11 of [7], equals the one originated from a variation of $\sim 8 \text{ wppm}$ Nitrogen concentration in Lithium.

The other requirement for a meaningful resistance measurement is the knowledge of the resistance of the RM steel capillary alone (R_{cell}), without Lithium inside. This implies that the resistance must be measured also before the first circulation of Lithium, since, after that, it is not possible to completely remove Lithium from the RM capillary, even when completely draining the purification loop. Once filled by Lithium, the RM may only measure the total electric resistance exerted by the capillary section (R_{tot} : due to the parallel paths of Lithium and steel): if we want to know the real resistance value of the Lithium alone (R_{Li}), it is possible to obtain it through the expression for parallel resistances:

$$R_{Li} = R_{cell} \times R_{tot} / (R_{cell} - R_{tot}) \quad (2)$$



Figure 3: Real shot of the Resistivity Meter (prior of its installation inside Lifus 6 plant)

2.1.2 Deeper analysis of the contributions to the measured electrical resistance

As reported in [11], when the RM was operated at Brasimone room temperature ($\sim 11.7^\circ\text{C}$), the acquired value of electrical resistance of the empty capillary (R_{cell}) resulted $5.326 \text{ m}\Omega$. Taking into account the theoretical 316L steel resistivity at this temperature ($0.764 \mu\Omega \text{ m}$, as interpolated from Table 4 of [12]) and the geometry of the RM capillary (as presented in [7]: length = 150 mm; area: $2 \cdot \pi \cdot (2.4^2 - 1.5^2) = 22.05 \text{ mm}^2$), the theoretical resistance should have been about $5.20 \text{ m}\Omega$. The agreement of the measured/theoretical values is good and indicates the RM is giving values which make sense.

The trend of R_{cell} with temperature was then investigated: it is reported in Figure 4 (red plot). It is possible to see that the resistance is perfectly fitted by a parabolic curve (black plot). It is also possible to compare the experimental values of R_{cell} with the calculated ones, on the basis of the RM geometry and of the values of AISI 316L resistivity (ρ_{SS}) reported in literature [12], all over the temperature range ($\sim 20 \div 300^\circ\text{C}$): blue plot in Figure 4 is the graphical representation of these theoretical values.

It is evident that all over the temperature range the experimental values are higher than the theoretical ones. A partial reason of this discrepancy could be that the tabulated values of AISI 316L in [12] are affected by some degree of uncertainty (5%); another partial explanation could lie in the dimensional precision of the Resistivity Meter; finally the deformation of the RM capillary with temperature may partially justify the divergence with temperature of the blue and red plots (both an elongation of the capillary and a thinning of its thickness tend to increase the electrical resistance). Anyway, to improve the agreement between the experimental and the theoretical result, an additional contribution to the total measured resistance was considered, i.e. the resistance due to the steel plates where the electrical wires are connected (R_p). In this case, R_{cell} becomes the sum of 2 contributions: R_{SS} (due only to the RM capillary) + R_p .

Unfortunately, the theoretical calculation of R_p was very complex because of the geometry of the system. For such a problem, a finite element analysis program should be used to get an estimated value of R_p . The problem was therefore alternatively solved by ENEA by measuring R_p inside a specific electrical sub circuit, from a measured voltage drop and employing a known measurement current.

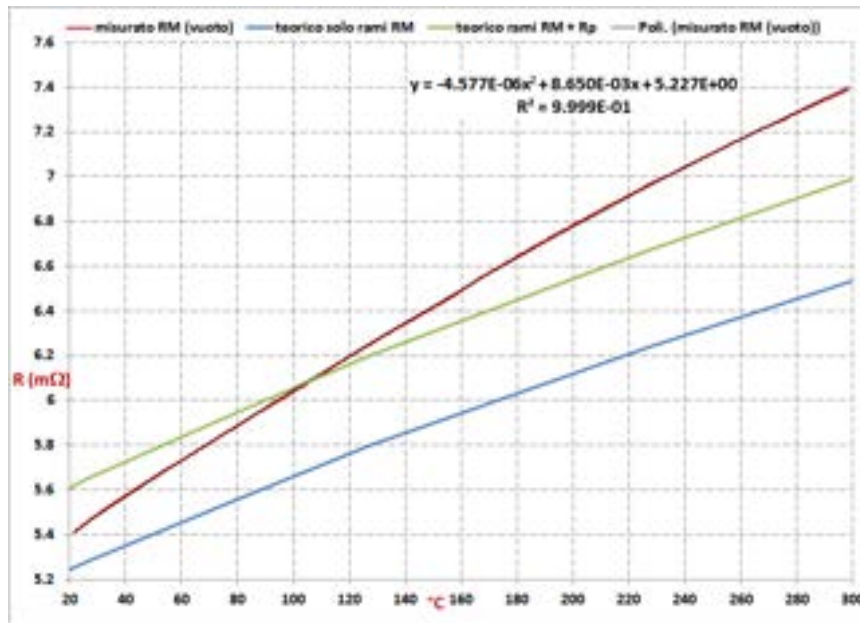

Figure 4: empty RM resistance values vs temperature. Red: experimental points; Black: fitting line of the experimental points; Blue: theoretical values for the steel capillary; Green: theoretical value of the capillary + R_p

At the Resistivity Meter temperature equal to 20.0°C, using a current $i=0.5$ A, the voltage drop was measured as 0.1766 mV. Therefore:

$$R_p = 0.1766 \text{ mV} / 0.5 \text{ A} = 0.3532 \text{ m}\Omega$$

Considering the geometry of the plate not affected by temperature variations, it was possible to estimate the value of R_p at each value of temperature, simply taking into account the AISI 316L resistivity variation with temperature [12]. For example, since

$$\rho_{SS} = 77.1 \times 10^{-8} \Omega\text{m} @ 20^\circ\text{C} \quad \text{and} \quad \rho_{SS} = 99.0 \times 10^{-8} \Omega\text{m} @ 350^\circ\text{C}$$

using the ratio of the resistivities at the two temperatures, the estimated value of R_p at 350°C is calculated as:

$$R_p = 0.3532 \text{ m}\Omega * 99.0 / 77.1 = 0.4535 \text{ m}\Omega$$

Applying this calculation to many selected values of temperature and adding this contribution to the theoretical resistance evaluated for the steel capillary alone at each respective temperature, it was possible to achieve a new set of 'corrected' values for the total resistance of the empty Resistivity Meter. The ensemble of these values is reported in graphical form as the green plot of Figure 4: it is evident that the agreement with the red 'experimental' one has been significantly improved respect to the blue one. This confirms that the supposition about the presence of an additional contribution to the resistance was right.

Inverting the argument, it is possible to know the resistance of the empty steel capillary alone (R_{SS}) at each temperature, by subtracting from the measured resistance (R_{cell}) the value of R_p at that temperature (violet plot in Figure 5).

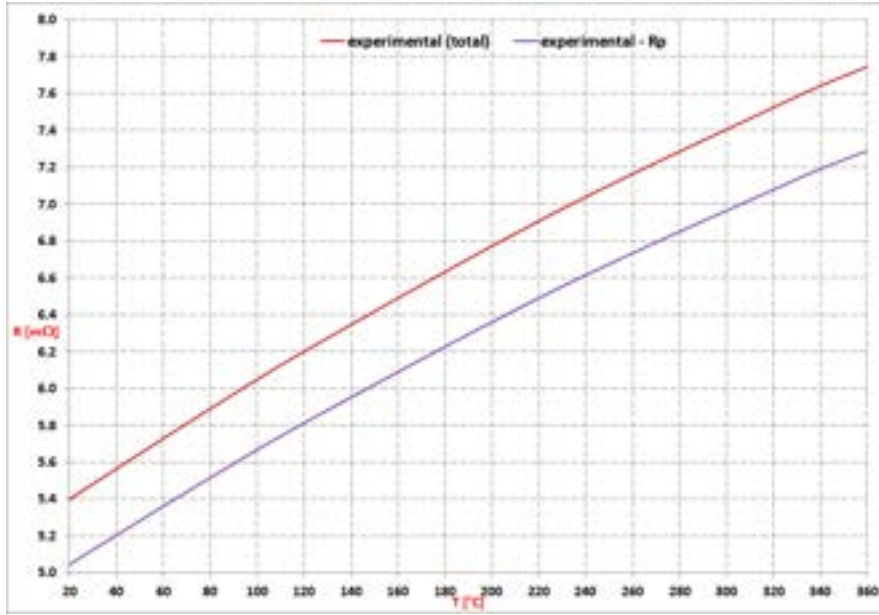

Figure 5: Empty RM resistance values vs temperature. Red: experimental points (same as in Figure 5); Violet: R_{SS} , after subtraction of R_p from R_{cell} .

For the practice of real measurements, when working with Lithium, we must consider the presence of R_p as well, and that R_{Li} is in parallel with R_{SS} . Assuming R_p doesn't change in presence or absence of Lithium (it is an external contribution, in series with the Lithium+steel capillary system), the total measured resistance (R_{tot}) is hence:

$$R_{tot} = R_p + (R_{SS} // R_{Li}) \tag{3}$$

where the symbol “//” means the two resistances must be added through the formula for parallel resistances. Equation (2) therefore becomes:

$$\begin{aligned} R_{Li} &= R_{SS} \times (R_{tot} - R_p) / [R_{SS} - (R_{tot} - R_p)] = (R_{cell} - R_p) \times (R_{tot} - R_p) / [(R_{cell} - R_p) - (R_{tot} - R_p)] = \\ &= (R_{cell} - R_p) \times (R_{tot} - R_p) / (R_{cell} - R_{tot}) \end{aligned} \tag{4}$$

2.1.3 Measurement with the Resistivity Meter filled by Lithium

The trend of the resistance values at the moment of the first filling of the RM with Lithium is shown in Figure 6. Blue plot is actually the electrical resistance, while the red plot is the RM temperature, divided by 50 in order to get values close to the resistance ones and have a contemporary look at both the quantities (therefore the maximum red value in the graph, ~ 6, corresponds to 299.43°C). X axis is time expressed in seconds, where each span (43200 s) corresponds to 12 hours.

The left part of Figure 6, up to the resistance value of 7.399 mΩ, corresponds to the empty Resistivity Meter and is not but the trend already presented in Figure 5 on a compressed scale. After about 200ks anyway Lifus 6 plant (hence the RM) was filled by Lithium: this fact is properly reflected by a sudden decrease in the resistance, which gets down to an average (not stable) value of ~ 2.43 mΩ, which is in good agreement with the theoretical one at that temperature (~ 2.48 mΩ) considering Lithium and steel capillary in parallel plus the R_p contribution. Temperature is then lowered and it is possible to see another sudden decrease of resistance around the Lithium solidification. During the transition period the average registered temperature alone is not able to justify the resistance trend, since many other factors play a role, mainly

the latent heat and the volume reduction during the solidification, the delay in the thermal stabilization, the parasitic current due to the on/off state of the RM EMP (electromagnetic pump).

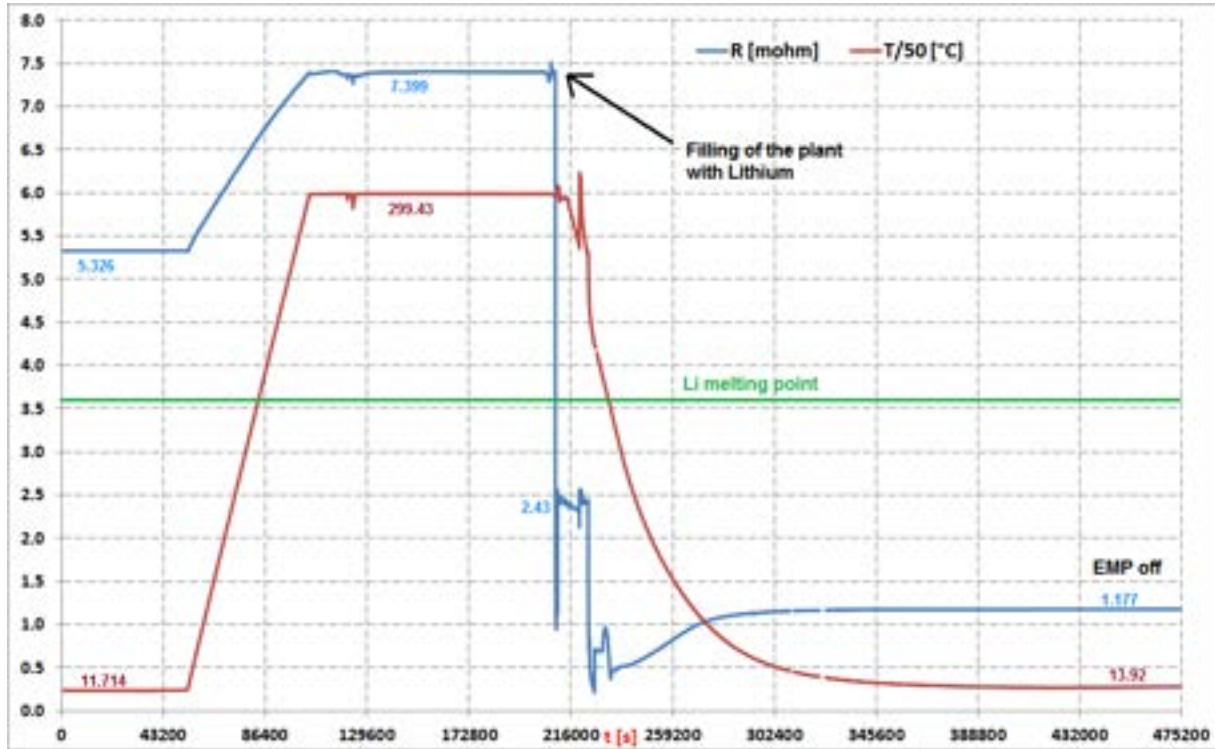

Figure 6: Resistance and temperature variation at the moment of the first filling of RM with Lithium

It is anyway possible to analyze the final state of the system, on the right, corresponding to the RM filled by solid Lithium at 13.92°C and with the EMP off. The theoretical resistance of solid Lithium is given by [10]:

$$\rho_{Li} [\Omega m] = 8.685 \times 10^{-8} + 3.261 \times 10^{-10} (T/^{\circ}C) + 1.821 \times 10^{-13} (T/^{\circ}C)^2 \quad (5)$$

At 13.92°C, this equation gives: $R_{Li} = 0.9700 \text{ m}\Omega$. At the same temperature $R_{cell} = 5.347 \text{ m}\Omega$, while $R_p = 0.351 \text{ m}\Omega$. Putting together these values, the theoretical value for R_{tot} results 1.163 mΩ. The measured value is 1.177 mΩ. The agreement is very good and witnesses the soundness of the adopted model and equations.

When working with liquid Lithium, which is actually our field of application, many complications emerge. During the many months of experimentation and study of the behavior of the system, the following elements have been pointed out.

The first important fact is that a proper resistance reading, stable, affected by a limited noise and comparable during time, can be obtained only when both the RM and the upstream purification pipeline (to which the RM is linked) are set and operating at the same temperature, i.e. in isothermal conditions. If this condition is not respected, the real temperature of Lithium in the RM may not exactly correspond to the value registered by the 4 Pt-100 sensors, being affected to some extent also by Lithium temperature upstream of the RM. Additionally, also changes in Lithium flow rate in the purification loop may introduce fluctuations in the local temperature. For all these reasons, resistance values can be compared only when acquired at the same RM temperature, with the same 'upstream' temperature and with the same flowrate in the purification loop (from which the RM spills a trivial fraction of Lithium).

The other key aspect of the measurement is the setting (on/off) of the mini Electromagnetic pump (EMP) of the Resistivity Meter, the one that drives Lithium through its capillary (see Figure 3). After a long experimentation it was concluded that, despite a small additional contribution to the signal noise, the EMP must always be on. Conversely in fact, if the pump was always off, it would cause Lithium to be static inside the RM and not to be representative of all the Lithium flowing inside the plant; if the pump was instead stopped only at the moment of execute a measure and then restarted (alternate on/off), it would not be possible anyway to restore equilibrium conditions inside the RM capillary on a small time scale after the measure (long drift; 1-2 hour at least required for the new stabilization of the parameters).

Figure 7 is an example of a resistance measurement obtained working with the above expedients. It is possible to see that during the investigated period (50') the difference between the highest and lowest resistance values is only $\sim 0.9 \mu\Omega$, with oscillations around the average value not exceeding $\pm 0.5 \mu\Omega$. This order of magnitude of oscillations was confirmed in all the experimentation and is considered acceptable for a qualitative Lithium monitoring: $0.5 \mu\Omega$ corresponds to ~ 30 wppm of Nitrogen concentration in the surrounding of 350°C .

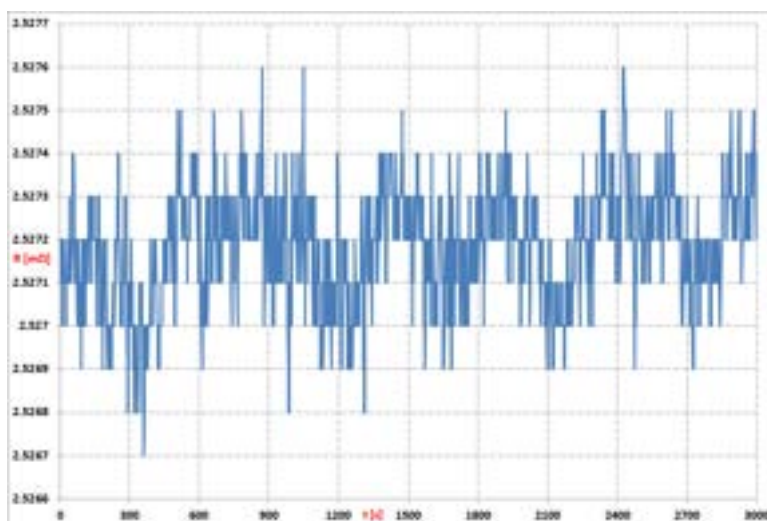

Figure 7: Electrical Resistance values vs time (online measure)

To conclude, it must be said that it is not possible to get from the RM a precise knowledge of the absolute composition of the flowing Lithium at a given temperature (the RM is very sensitive to too aspects), but it is anyway possible to have a rough estimation of the overall impurities content and mostly to investigate the relative resistance variation with time. In practice, small deviations of the resistance value can be easily detected and indicate if the composition is even slightly changing (a variation of 10 wppm in Nitrogen/Hydrogen concentration would theoretically produce a variation respectively of $\sim 0.16/1.2 \mu\Omega$).

2.2 Lithium purification operations before the start-up of the erosion-corrosion test

As already described in [11], Lithium was purified from Carbon, Oxygen and partly Hydrogen during the long Lifus 6 commissioning phase. This phase, completed at the beginning of August 2015, lasted many months, during which Lithium was allowed to flow also through the Cold Trap. C, O and H concentration in Lithium cannot be evaluated, since a specific analytical procedure is not foreseen for these elements, anyway their removal from Lithium at the end of this phase can be assumed on the basis of the theoretical evaluation related to the efficiency of the Cold Trap [7]. What was possible to measure, and it's also the most important purity information, is instead the concentration of Nitrogen. For this reason, the "U" shaped sampler (Sampler 1, see Table 1) installed along the purification loop was filled by Lithium; after

draining the plant (for safety reason) and cooling the sampler in order to solidify the metal inside, the sampler was detached from the plant and brought to the laboratory analysis. Operating inside the glovebox, the sampler was cut in two different positions and in correspondence of the cuts 0.6-0.8 g of Lithium were taken, to be subjected to the chemical analysis for the quantification of Nitrogen concentration, according to the procedure deeply described in section 5.3 of [8]. The details of the analysis result are reported in Table 2 below; Nitrogen concentration in Lithium was: **55.1 ± 9.0 wppm**.

Table 2: details of the analysis result of sampled Lithium at the end of the Cold Trap purification phase

Analysis n°	Lithium mass [g]	Nitrogen concentration found in the analysed solution [mg/L]	Nitrogen mass [mg] *	Nitrogen concentration in Lithium [wppm]
1	0.8015	0.1681	0.0370	46.2
2	0.6325	0.1819	0.0405	64.0
Mean				55.1
Systematic error (2.5% of the uncorrected)				1.56
Std. dev.				12.6
Random uncertainty				8.90
Total uncertainty				9.04

* after subtracting the blank value (5.0 µg)

Being this value higher than the requirement of the erosion-corrosion test (≤ 30 wppm), it was necessary to execute a purification step, this time employing the Hot Trap. Lithium was therefore transferred from the Storage Tank to the Hot Trap and its temperature increased to 550°C. Actually, the Hot Trap had been designed and realized to be able to work up to 650°C, but in its first employment it was decided to set a relatively low temperature, to minimize the possible corrosion action by Lithium on the construction material of the trap and to get results comparable to those achieved by the IFMIF Japanese partner, who selected 550°C as working temperature. After 30 hours of Lithium staying in contact with Titanium sponge getter inside the trap, the temperature was reduced and the Lithium sampler installed directly above the Hot Trap [7] (Sampler 2, see Table 1) was filled by Lithium. The Lithium was then transferred back from the Hot Trap to the Storage Tank for safety reason and after the complete cooling of the sampler (and the solidification of Lithium inside it), the sampler was detached from the trap and brought to the chemical lab for the analysis.

The ‘mushroom’ shaped sampler removed from the Hot Trap is larger and heavier than the ‘U’ tube sampler along the purification loop, moreover it is not completely filled by Lithium, but it is filled only in its bottom part (about 25 mL), while the volume above Lithium remained filled by Argon gas. To take a part of Lithium for the chemical analysis, the sampler must not be cut (in a destructive way), but opened, since the sampler is composed by two parts, a lower cylindrical container and a flanged lid, airtight closed with bolts; moreover the sampler must be recycled after the usage (after, of course, a complete cleaning). Since the bolts had been strongly tightened at the moment of the installation, it was necessary to partially loosen them with the proper utensil before introducing the sampler in the glovebox, where movements and applicable force are limited; after the insertion, the complete opening of the sampler was realized with the right spanner.

Lithium removal from the open container was not very easy, because Lithium formed a very compact block, hence it could be removed only by chiseling and digging with a sharp screwdriver and collecting it in several small pieces. To get an amount of at least 0.5g, almost half an hour of operation was necessary. Unfortunately, this implied that the Lithium surface exposed to the glovebox atmosphere (measured Oxygen concentration ~ 10 ppm; Nitrogen concentration supposed to be 4 times the Oxygen one) tended to be contaminated to some extent during this long operation time. The sampled Lithium (in the bowl) and the remaining one in the sampler are shown by Figure 8. It is possible to note the surface of the exposed Lithium in the bottom of the container is partially darkened, while where the surface was digged Lithium appears shining.



Figure 8: Lithium transferred in the bowl and remained in the sampler (inside the glovebox)

Lithium taken from the sampler was then analyzed according to the same chemical procedure [8], even if, being not feasible to exclude the contact of Lithium inside the sampler with the glovebox atmosphere after the opening of the sampler, it was not possible to replicate the analysis during the following days: a higher contamination affected the metal, which was completely covered by a whitish patina, very sticky and still harder to remove from the container. Therefore, only one chemical analysis was performed. The details of its result are reported in Table 3; Nitrogen concentration in Lithium was: **25.6 ± 2.7 wppm**.

Table 3: Details of the analysis result of Sampler 2 Lithium after the first step of the Hot Trap purification

Analysis n°	Lithium mass [g]	Nitrogen concentration found in the analysed solution [mg/L]	Nitrogen mass [mg] *	Nitrogen concentration in Lithium [wppm]
1	0.5303	0.0704	0.01360 ± 0.0010	25.6 ± 1.9
			Systematic error (2.5% of the uncorrected)	0.83
			Blank uncertainty	1.9
			Total uncertainty	2.7

* after subtracting the blank value (4.0 ± 1.0 µg).

Two considerations require now to be done. The first one is that, as a general rule, the direct sampling from the Hot Trap could not lead to proper result, due to the more difficult handling and the possible higher contamination of Lithium. The analysis from the 'U' tube along the purification (sampler 1) is not affected instead by this risk of contamination, since Lithium fills the entire sampler and the second taking is done in correspondence of a new cut of the sampler, far from the first one, where Lithium hadn't the possibility yet to come in contact with external atmosphere. The sampling and analysis from the Hot Trap sampler could therefore give only a single trustable result, not a second one, at least with the above described procedure.

The second consideration is that the found value of 25.6 ± 2.7 wppm already corresponded to a Lithium good for the erosion-corrosion test, since it was lower than 30 wppm. Of course, considering that only one analysis result indicated this compliance, it was decided to verify it again and, in view of the previous consideration, to perform this time the sampling of Lithium from sampler 1.

Before the sampling, it was decided anyway to perform an other purification step by the Hot Trap. In this case the duration of the purification was ~ 381 hours, while Lithium temperature in the trap was the same of the previous step (550°C). After lowering the temperature to 250°C and transferring back Lithium to Lifus 6 loop, Lithium was sampled was done from sampler 1 in the purification loop. Lithium was then analyzed twice, according to the usual procedure. The details of the analysis result are reported in Table 4; Nitrogen concentration in Lithium was: 31.9 ± 5.3 wppm.

Table 4: details of the analysis result of Sampler 1 Lithium after the second step of Hot Trap purification

Analysis n°	Lithium mass [g]	Nitrogen concentration found in the analysed solution [mg/L]	Nitrogen mass [mg] *	Nitrogen concentration in Lithium [wppm]
1	0.8014	0.1267	0.02398 ± 0.0032	29.9 ± 4.0
2	0.8533	0.1465	0.02893 ± 0.0032	33.9 ± 3.75
Mean				31.9 ± 3.87
Systematic error (2.5% of the uncorrected)				1.03
Syst + blank				4.90
Std. dev.				2.82
Random uncertainty				2.00
Total uncertainty				5.29

* after subtracting the blank value (7.7 ± 3.2 μg). Unfortunately the blanks performed in correspondence of this sample were characterized by high and rather unreproducible values.

This result is close the previous one (25.6 ± 2.7 wppm); if the estimated uncertainties around both of them are considered, it is also possible to see an overlap of values in the range (26.6-28.3) wppm. What is clear, anyway, is that the Hot Trap didn't further reduce Nitrogen concentration during these additional 381 hours and that Nitrogen concentration remained around the value at the end of the first 30 hours of purification. On the other side, even if the Hot Trap appeared to be ineffective, it's rather unlikely that it led to an increase of Nitrogen concentration, so it's likely instead that the small difference between the 2 results can be ascribed to the uncertainties in the analyses.

Summarizing the Nitrogen concentration results presented in this section, it must be observed that they all were rather low in absolute values, since the highest was around 55 wppm. From one side, this fact can be considered negative, since working with this 'good quality' Lithium didn't permit to sufficiently characterize the Hot trap efficiency, being registered concentration variations very small and consequently the number of requested samplings limited to only 3. On the other side, this fact was positive, since the overall time required for the purification phase was short and the purity goal (≤ 30 wppm) easily achieved. It was so possible to start the first erosion-corrosion test (short term test).

2.3 Purification devices behavior during the Erosion-Corrosion Test

The first erosion-corrosion test (Short Term Test) realized the exposition of RAFM specimens to flowing liquid Lithium at 330°C for 1222 hours, by inserting them in the Test Section of Lifus 6 plant.

It must be said that no significant problem occurred during the Test period, the only one was an unexpected stop of the electricity supply to the plant, due to a problem of the external (public) grid. This event, which occurred around the 15th day of the Test, lasted only for about a couple of hours and provoked the stop of the pump and the heating/cooling elements of the plant, even if the electronics (like RM) and the Data Acquisition and Control System remained active, since fed by an UPS system.

The test was perfectly accomplished, for what concerns the thermal and dynamic conditions of Lithium in the Test Section: temperature inside the Test Section, where the investigated specimens are located, was registered in the range of 330-331°C during the entire test period; the Lithium flow rate was always in the range of 28-30 L/min (a part from the 2 hours mentioned stop), value which assures a metal linear speed of about 15 m/s [7].

Let's focus now on the behaviour of the purification devices during the test. Figure 9 reports the values assumed by the electrical resistance of Lithium flowing through the Resistivity Meter during the 51 days of the test. The graphic is characterized by the presence of almost constant tracts (the longest one lasts about 18 days, from ~ day 15 to ~ day 33), even if there are visible also sudden increases and also a decreasing trend after day 35. Since we know that the RM is actually sensitive to many experimental parameters, to rationalize the resistance values it's convenient to look also at the registered values of the temperature around the RM (Figure 10), as well as at the Lithium flow rate in the purification loop (Figure 11) and at the Cold Trap temperature (Figure 12).

The first thing to note is that all these trends clearly indicates a discontinuity in correspondence of day 15, when the electricity supply was momentarily arrested. The flow rate of Lithium in the purification loop in fact went down to 0 (out of Figure 11 scale), but the stop is reflected also by Figure 12, when, being the Cold Trap Air cooler momentarily out of service, the Cold Trap temperature significantly increased, up to around 250°C. Of course a discontinuity is present also in the RM zone temperatures (Figure 10), where the stop of electricity provoked a small decrease of temperature, and also in the electrical resistance, which was similarly decreased by the decrease of temperature. These sudden drops in the registered values were followed by likewise sudden increases in each of the registered quantities, when the system tried to restore as fast as possible the conditions before the stop.

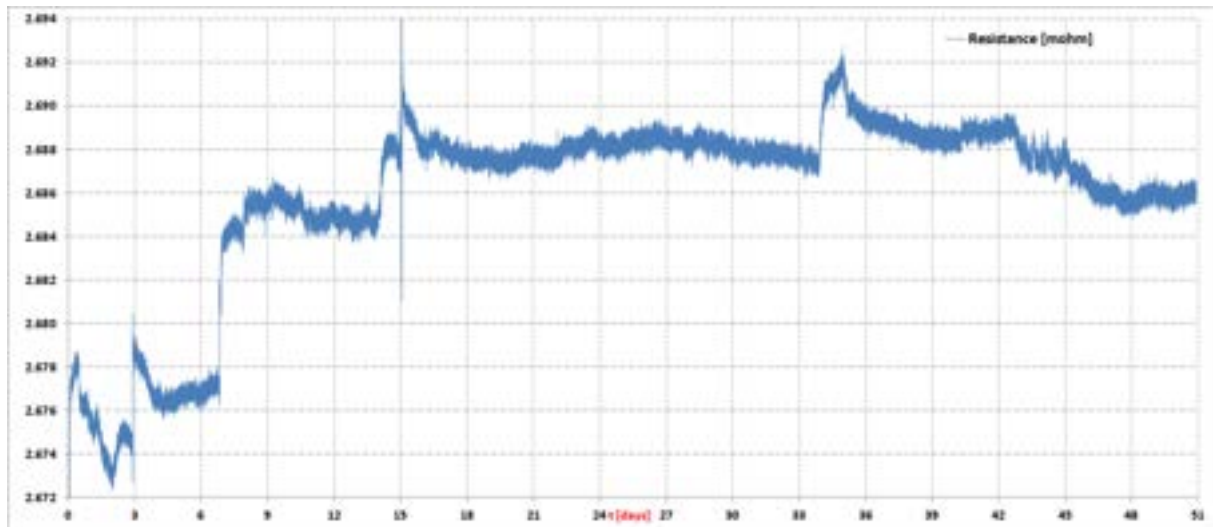

Figure 9: trend of the Lithium electrical resistance during the 51 days of the Short Term Test

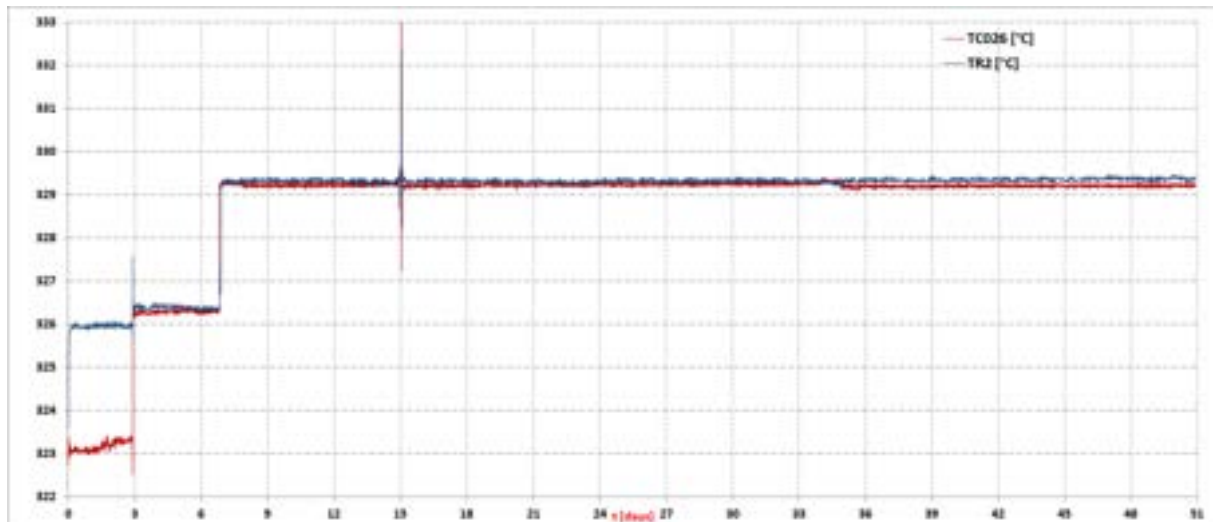

Figure 10: trend of the temperature of the RM measurement capillary (TR2, blue plot) and of the purification pipe just upstream of the RM (TC026, red plot) during the 51 days of the Short Term Test

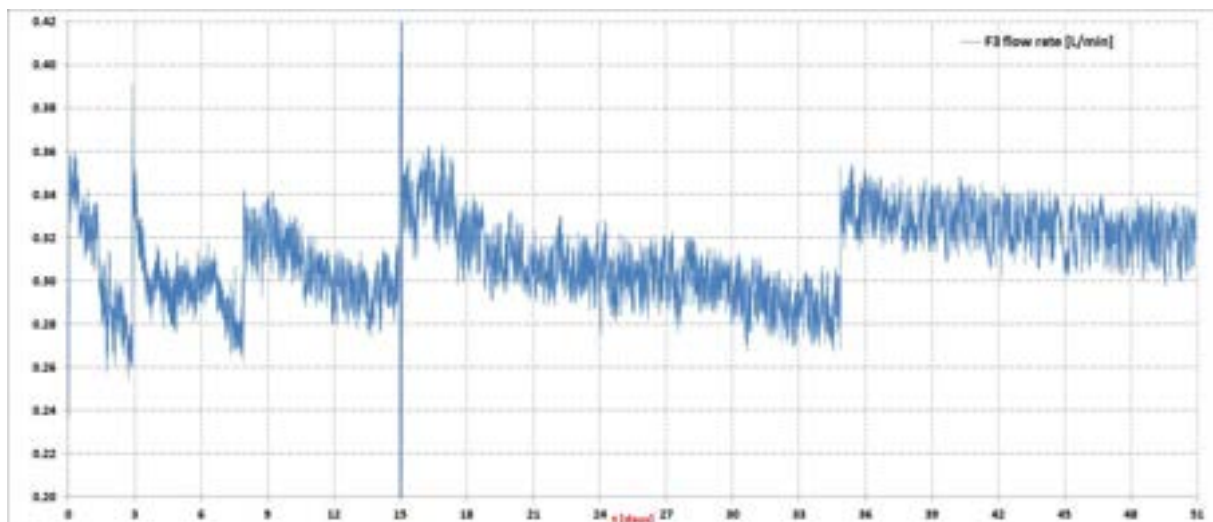

Figure 11: trend of the Lithium flow rate (F3) in the purification loop during the 51 days of the Short Term Test

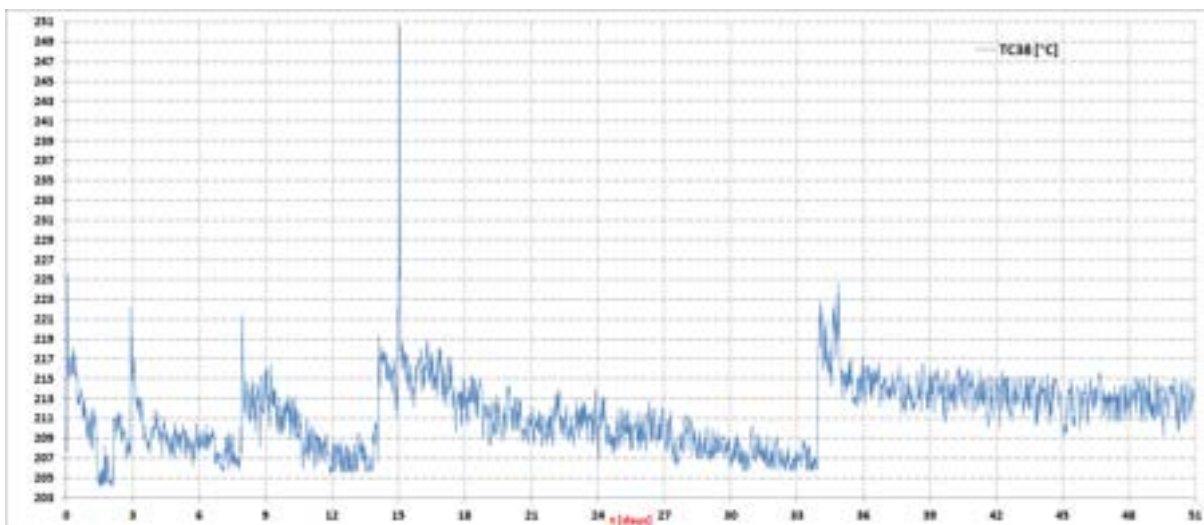

Figure 12: trend of the Cold Trap temperature (TC038) during the 51 days of the Short Term Test

Another thing to mention is that the first days of the test, until about day 7, were necessary to find stable and optimal Lifus 6 working conditions. In fact, it must be emphasized that the valve which regulates the flow rates of Lithium through the purification loop – this valve is asked to reduce the flow rate of Lithium from the value in the main loop (~ 30 L/min) to about 1% in the purification loop (~ 0.30 L/min) – is a manual one. Therefore it must be progressively adjusted at the beginning, to compensate density and viscosity variations of Lithium with temperature, until Lithium temperature has stabilized to the test correct value. At the same time, a variation in the flow rate in the purification loop, hence across the Cold Trap Air cooler and the Trap itself, affects the Lithium temperature in the Cold Trap, since, the higher the flow rate, the smaller the time available to Lithium to be cooled from 330°C . This is clearly seen by comparing the entirety of Figure 11 and Figure 12: the trends of the plots are very similar. On the whole, we can say that the Cold Trap temperature operated, during the test, in the range of $205\text{-}220^{\circ}\text{C}$, with an average value of $\sim 211^{\circ}\text{C}$: this value, a part from the oscillations, is a bit higher than the test specifications (200°C), anyway it must be said that the thermocouple is not in direct contact with Lithium, therefore the real Lithium temperature is estimated to be some $^{\circ}\text{C}$ smaller. Due to the difficulty of assuring a long time stability of the trap temperature, it was decided to keep a few degrees margin above 200°C , in order not to risk Lithium solidification inside the trap.

Coming back to the trend of the electrical resistance and putting together all the above considerations, we can infer:

- the abrupt increases of resistance at day 3 and day 7 arise from the abrupt increases in the TR2 and TC026 temperatures, which are derived by a similar increase of Lithium temperature in the main loop. These resistance increases are also in good quantitative agreement with the theoretical previsions on the effect of temperature. In fact, from the beginning of the test to day 7, these temperatures grew on the whole by about 6°C , while Resistance appears to grow by about $12\ \mu\Omega$: this corresponds to $\sim 2\ \mu\Omega$ for every $^{\circ}\text{C}$, in accordance with what already foreseen [7].
- The increases of resistance at day 14 and day 34 can be related to similar increases in the flow rate and in the Cold Trap temperature. Mostly, considering that the electricity stop at day 15 provoked the Cold Trap jump to almost 250°C , it can be argued that a partial re-dissolution of the solid impurities precipitated in the trap took place. Since all the non metals impurities and particularly Hydrogen are able to affect Lithium electrical resistance, it is likely that the increased value of resistance after day 15 may be actually ascribed to the occurrence of a slightly higher impurity level in Lithium. Even if the trap temperature tended to decrease immediately after day 15, a similar trend

cannot be retrieved in the electrical resistance, mainly because the re-precipitation of solved impurities requires longer time. The long range functioning of the Cold Trap can be anyway inferred by the fact that at the end of the test (day 51), resistance assumes about the same value of day 9, in absence of a diminution of the RM temperature (Figure 9) and having been not performed by the Hot Trap any purification of Lithium from Nitrogen. From a quantitative point of view, a jump in the Cold Trap temperature of about 15°C, like the one around day 34, would theoretically produce an increase in the Hydrogen solubility of about 30 wppm, which in turns would translate into a resistance increase of ~ 3.6 $\mu\Omega$ [7]: this value agrees well with the jump observed in the resistance value at the same moment (~ 4 $\mu\Omega$), moreover considering that a small additional contribution could be given by Oxygen and Carbon possible re-dissolution.

- On the whole, the electrical resistance trend doesn't indicate an increase in Nitrogen concentration in Lithium during the test. The variations of resistance, however limited to less than 20 $\mu\Omega$, have been explained in terms of small variations in temperatures and flow rates of Lithium, but the fact that at the end of the test the resistance value comes back to day 9 value (same RM temperature) excludes a significant contamination from Nitrogen, to which the RM is particularly sensitive. Only a minor contamination from other impurities can be supposed (they cannot be directly measured), but it was in case suppressed by the long time range action of the Cold Trap.

The offline chemical analysis was anyway executed at the end of the test, to confirm the previous conclusion on the keeping of a low value of Nitrogen concentration. After filling sampler 1 with Lithium and cooling it to room temperature, it was detached from the plant and brought to the chemical lab. Two analyses were executed on this Lithium, by cutting in two different points the sampler and taking ~ 0.6-0.7 g of metal in correspondence of each cut. The details of the analysis result are reported in Table 5; Nitrogen concentration was **28.7 ± 2.7 wppm**.

Table 5: details of the result of the analysis of Lithium sampled just after the conclusion of the Short Term Test

Analysis n°	Lithium mass [g]	Nitrogen concentration found in the analysed solution [mg/L]	Nitrogen mass [mg] *	Nitrogen concentration in Lithium [wppm]
1	0.7739	0.1159	0.02388 ± 0.0005	30.9 ± 0.6
2	0.6132	0.08555	0.01629 ± 0.0005	26.6 ± 0.8
Mean				28.7 ± 0.7
Systematic error (2.5% of the uncorrected)				0.90
Syst + blank				1.6
Std. dev.				3.04
Random uncertainty				2.15
Total uncertainty				2.68

* after subtracting the blank value (5.1 ± 0.5 μg).

This value is perfectly aligned to the ones related to the condition of Lithium at the start of the test, as reported in Table 3 and 4. Therefore it can be concluded, as already deduced from the electrical resistance trend, that no Nitrogen contamination occurred during the test and that the Nitrogen concentration complied with the LF03-PA requirement for the entire test duration.

2.4 Lithium quality and purification operations after the first erosion-corrosion test

Later, it was necessary to open the Test Section of Lifus 6 plant to remove the specimens exposed to Lithium and to replace them with fresh ones aimed at the Mid Term Test (2000 hours). The operation was performed flowing Argon inside the Test Section, from the bottom, to avoid air entering the plant. Anyway, before starting the new erosion-corrosion test, Nitrogen concentration in Lithium was checked again, to exclude possible contamination happened during this time. Sampler 1 was employed, performing as usual two separate analysis on the Lithium inside. The details of the analysis result are reported in Table 6; Nitrogen concentration was **123.0 ± 17.2 wppm**.

Table 6: details of the result of the analysis of Lithium after the replacement/maintenance operation

Analysis n°	Lithium mass [g]	Nitrogen concentration found in the analysed solution [mg/L]	Nitrogen mass [mg] *	Nitrogen concentration in Lithium [wppm]
1	0.6713	0.3956	0.09381 ± 0.0005	139.7 ± 0.7
2	0.6559	0.2994	0.06976 ± 0.0005	106.4 ± 0.8
Mean				123.0 ± 0.75
Systematic error (2.5% of the uncorrected)				3.27
Syst + blank				4.0
Std. dev.				23.6
Random uncertainty				16.7
Total uncertainty				17.2

* after subtracting the blank value (5.1 ± 0.5 µg).

This result, a part from its rather large error bar, indicates that unfortunately some air entered the plant, increasing Nitrogen concentration in Lithium to a value surely not suitable for the next erosion-corrosion test. For this reason, Lithium was transferred again in the Hot Trap and left in contact with the Titanium getter for about 139 hours, this time at 600°C. Then, after cooling the Hot Trap, Lithium was transferred back to the plant loop, where it was allowed to fill sampler 1. Once cooled, the sampler was detached from the plant and brought to the chemical lab for the Nitrogen analysis. Two analyses were executed on this Lithium, by cutting in two different points the U-tube sampler and taking ~ 0.6-0.7 g of Lithium in correspondence of each cut. The details of the analysis result are reported in Table 7; Nitrogen concentration resulted **35.7 ± 6.3 wppm**.

Table 7: details of the result of the analysis of Lithium sampled after 139 hours in the Hot Trap at 600°C

Analysis n°	Lithium mass [g]	Nitrogen concentration found in the analysed solution [mg/L]	Nitrogen mass [mg] *	Nitrogen concentration in Lithium [wppm]
1	0.6135	0.09711	0.01813	29.6
2	0.6489	0.1336	0.02719	41.9
Mean				35.7
Systematic error (2.5% of the uncorrected)				1.14
Std. dev.				8.73
Random uncertainty				6.17
Total uncertainty				6.27

* after subtracting the blank value 6.2 µg.

It appears that the Hot Trap step was able to actually reduce Nitrogen concentration in Lithium. The found value was slightly higher than the PA requirement (30 wppm), anyway, considering also the error bars, it was agreed to consider it not so far from the target and therefore to start the next corrosion test with such an impurity level.

Similarly, at the end of the Mid Term erosion-corrosion test (2000 hours), even if the electrical resistance trend registered during the test indicated no important Lithium contamination should have occurred, Nitrogen concentration in Lithium was checked with the offline chemical analysis. Again, the sampling of Lithium was executed employing sampler 1; this time, it was possible to perform only one single analysis of the sampled metal. The details of its result are reported in Table 8; Nitrogen concentration was: **31.1 ± 1.0 wppm**. This value is aligned to the one at the start of the test (35.7 ± 6.3 wppm) and confirms the good Lithium quality during the whole experiment.

Table 8: details of the result of the analysis of Lithium sampled just after the conclusion of the Mid Term Test

Analysis n°	Lithium mass [g]	Nitrogen concentration found in the analysed solution [mg/L]	Nitrogen mass [mg] *	Nitrogen concentration in Lithium [wppm]
1	0.7197	0.1135	0.02237	31.1
Systematic error (2.5% of the uncorrected)				0.99
Total uncertainty				0.99

* after subtracting the blank value 6.0 µg.

Later, it was necessary to open the Test Section of Lifus 6 plant to remove the specimens exposed to Lithium and to replace them with the fresh ones aimed at the last erosion-corrosion test (Long Term Test: 2000 hours more). Also in this case, before starting the new test, Nitrogen concentration in Lithium was checked, to exclude possible contamination happened during this time. Sampler 1 was employed, performing as usual two analysis on the Lithium inside. The details of the analysis result are reported in Table 9; Nitrogen concentration was **56.0 ± 5.9 wppm**.

Table 9: details of the result of the analysis of Lithium after the insertion of the Long Term test specimens

Analysis n°	Lithium mass [g]	Nitrogen concentration found in the analysed solution [mg/L]	Nitrogen mass [mg] *	Nitrogen concentration in Lithium [wppm]
1	0.6775	0.1603	0.03408	50.3
2	0.6655	0.1882	0.04106	61.7
Mean				56.0
Systematic error (2.5% of the uncorrected)				1.62
Std. dev.				8.06
Random uncertainty				5.7
Total uncertainty				5.9

* after subtracting the blank value 6.0 µg.

This result shows that, also in this case, some small Lithium contamination took place at the moment of opening the Test Section of the plant and replacing the specimens. For this reason, Lithium was transferred again in the Hot Trap and left in contact with the Titanium getter for about 169 hours at 600°C. The double chemical analysis of Lithium taken from sampler 1 after this purification step gave as result a Nitrogen concentration in Lithium equal to **14.1 ± 2.1 wppm**, as detailed in Table 10. The good quality of Lithium was hence restored by the Hot Trap purification step.

Table 10: details of the result of the analysis of Lithium sampled after 169 hours in the Hot Trap at 600°C

Analysis n°	Lithium mass [g]	Nitrogen concentration found in the analysed solution [mg/L]	Nitrogen mass [mg] *	Nitrogen concentration in Lithium [wppm]
1	0.6954	0.06904	0.01123	16.1
2	0.6123	0.05378	0.00741	12.1
Mean				14.1
Systematic error (2.5% of the uncorrected)				0.58
Std. dev.				2.59

Random uncertainty	2.02
Total uncertainty	2.10

* after subtracting the blank value 6.0 µg.

It can be concluded that Nitrogen concentration in Lithium was kept more or less constant during both the erosion-corrosion steps performed until now (the short and the mid term one), while a small contamination took place only at the moment of opening the plant for specimens replacement and other general maintenance operation. In any case, the Hot Trap proved its efficiency being able in both cases to lower in about a week Nitrogen concentration below the target value (≤ 30 wppm), in the second case down to even ~ 14 wppm.

2.5 Overall considerations on the Hot Trap efficiency

In this section, a summary of the results related to the purification of Lithium by the Hot Trap is presented, both during the first phase (commissioning of the plant and activities before the start of the first erosion-corrosion test) and during the second one (during the experimental tests, until the start of the Long Term one).

It must be firstly underline that a proper characterization of the Hot Trap and hence of its heart, the commercial Titanium getter in pellets, is not possible, due to the limited number of experiments performed and also to the rather small concentration variations registered in the analysed Lithium samples.

Lithium transferred in Lifus 6 from the old Lifus 3 plant appeared in fact to be already a 'good quality' Lithium, being the first measured Nitrogen concentration value, before any purification activity, around 55 wppm. It would be anyway ungrateful to the fate to complain about this fact, since the main purpose of Lifus 6 plant is the execution of the erosion-corrosion test and such a Lithium surely permitted to achieve the purity target for the test (30 wppm) in a short time.

Therefore only some qualitative consideration can be done at the moment. Since the Lifus 6 erosion-corrosion campaign will continue till about the end of 2016, it cannot be excluded anyway that some additional experimental data on the trap efficiency will be acquired and that some more quantitative consideration will be possible at the end of the entire campaign.

Let's start with the observation of the action exerted by the Hot Trap at 550°C. Table 11 summarizes the values of Nitrogen concentration measured in Lithium sampled just after each step of the Hot Trap purification.

Table 11: summary of the Nitrogen concentration values resulting from the Hot Trap action at 550°C.

Total purification time [hours]	Lithium/plant condition	Measured Nitrogen concentration [wppm]
0	End of the Cold Trap phase	55.1 ± 9.0 wppm
30	After 30 hours in the Hot Trap at 550°C	25.6 ± 2.7 wppm
411	After 381 hours more in the Hot Trap at 550°C: start of the Short Term test	31.9 ± 5.3 wppm

What is clear from the above table is that, even if the absolute values of concentrations are small, the Hot Trap plays a positive role in reducing Nitrogen concentration. After 30 hours of purification at 550°C, Nitrogen concentration was reduced in fact by 29.5 wppm, which, taking into account Lifus 6 Lithium inventory (~ 10.2 Kg), corresponds to the adsorption of ~ 300 mg of Nitrogen by the getter. It seems, on the other hand, that no additional reduction of Nitrogen was gained during the next purification step, in that the value after 381 hours more resembles the previous one (considering the error bars around the two values, they can be considered actually the same one). So, it can be inferred that, working at 550°C, the getter was not able to lower Nitrogen concentration in Lithium below about 30 wppm: maybe the few Nitrogen atoms adsorbed by Titanium were already enough to create a surface layer which hindered the prosecution of the adsorption, being scarce the residual Nitrogen concentration in Lithium and the temperature, hence the diffusion coefficient, which act as driving force for the gettering process.

Let’s look now at the behaviour of the Trap when operated at 600°C, at the end of the Short Term Test and in all the following operation. Table 12 summarizes the values of Nitrogen concentration measured in Lithium sampled just after each step of the Hot Trap purification.

Table 12: summary of the Nitrogen concentration values resulting from the Hot Trap action at 600°C.

Total purification time [hours]	Lithium/plant condition	Measured Nitrogen concentration [wppm]
0	End of the Short Term test	28.7 ± 2.7 wppm
0	After the replacement of the specimens aimed at the Mid Term Test	123.0 ± 17.2 wppm
139	After 139 hours in Hot Trap at 600°C: start of the Mid Term test	35.7 ± 6.3 wppm
0	End of the Mid Term test	31.1 ± 1.0 wppm
0	After the replacement of the specimens aimed at the Long Term Test	56.0 ± 5.9 wppm
169	After 169 hours in Hot Trap at 600°C: start of the Long Term test	14.1 ± 2.1 wppm

The 1st of purification step at 600°C (139 hours, before the start of the Mid Term Test), produced a tangible variation of Nitrogen concentration, corresponding to a diminution of 87.3 wppm, which, taking into account the mass of purified Lithium, corresponds to an adsorption by the getter of about 890 mg of Nitrogen. It is important to note that raising the temperature to 600°C allowed the Hot Trap to rescue its gettering function, that seemed lost or momentarily shelved at the last stage of 550°C operations. So, that apparent saturation could be overcome by raising the temperature, which translated into a speedup of the kinetics of the adsorption and diffusion of Nitrogen in Titanium.

The 2nd step of purification at 600°C (169 hours, before the start of the Long Term Test) was able to reduce again Nitrogen concentration, by 41.9 wppm, which taking into account the mass of purified Lithium, corresponds to an adsorption by the getter of about 427 mg of Nitrogen. It is important in this case to observe that the final value (14.1 wppm) is significantly lower than the minimum value achieved at 550°C (~ 28-30 wppm) and it cannot be excluded that, allowing Lithium to stay in contact with the getter for additional time, could lead to even lower concentration values. At least for the moment, a minimum achievable Nitrogen concentration value wasn’t hence found working at 600°C, promoting Titanium sponge as a promising getter also for future Lithium applications.

3 Conclusioni

Since the purpose of Lifus 6 purification system is to guarantee that the purity level of Lithium during the erosion-corrosion tests complies with the IFMIF LF03 task requirement, it can be concluded, on the basis of both the registered electrical resistance trend and mostly the offline chemical analyses, that the purification system fulfilled his duty for what concerns the Nitrogen contamination, in that the Nitrogen concentration requirement (≤ 30 wppm) was matched all over the first and the second test period (the third and last one has just started, the 30th of August), giving in turn validity to the result of the test itself.

Some uncertainty is instead kept for what relies to the presence of other non metallic impurities in Lithium (Carbon, Hydrogen, Oxygen), for which a specific analytical technique is not available, but this is a limit we already knew, therefore we are forced to trust in theoretical estimations. It cannot be excluded that during the experimental erosion-corrosion test a small increase of the total amount of this type of impurities could have occurred, as a consequence of the accidental raise of the Cold Trap temperature: anyway, looking in depth at the main purification parameters trend, it seems that the slightly bigger concentrations of these non metals in Lithium were progressively re-conducted to their respective values at the start of the test, being the final resistance value very close to the starting one (at the same temperature).

This last observation permits also to state that the Cold Trap, even if a direct instrument to assess its efficiency is lacking, produces however to some extent the removal of many elements from the flowing liquid Lithium, being continuously operated on a fraction ($\sim 1\%$) of the total circulating metal, therefore realizing the contact with the entire Lithium only through iterative mixings steps.

For what concerns the Resistivity Meter, this device has been widely investigated, both performing prior theoretical evaluations on its efficiency and on the soundness of the produced results, both making a lot of experimental tests aimed at finding out its optimal measurement conditions. Here it can be concluded that the absolute value of the measured electrical resistance of Lithium appeared to be in good numerical agreement with the theoretical previsions, considering the resistivity of pure Lithium and of the steel constituting the pipe of the capillary, the geometry of the measurement cell and also the presence of external contributions to resistance due to the sequence of conductors along the chain of electrical connections. Even the effect of the temperature on the resistance was shown to agree with theory, producing a change of $\sim 2\mu\Omega$ for each $^{\circ}\text{C}$ change in the surrounding of the Lifus 6 test/commissioning temperature (330/350 $^{\circ}\text{C}$).

An absolute quantification of the impurities concentration in Lithium remains anyway not possible with the Resistivity Meter, but once a starting value has been acquired at the beginning of an experiment, even small changes of Lithium conditions are easily detectable by this device: if all the other parameters are constant, resistance variations can be therefore ascribed to the total impurities variations. Unfortunately a precise correlation of the RM signal with the Nitrogen concentration in Lithium has been impossible until now, being all the available Lithium samples characterized by rather similar (and small in absolute value) Nitrogen concentrations. This correlation, and maybe even a kind of calibration curve, could be gained in future, if the RM will continue to find application in experimental Lithium plants, or it will be employed in small scale apparatus, in which measured Lithium will be expressly contaminated by Nitrogen gas to produce an higher concentration sample. It must be finally remarked that, being the RM very sensitive to any experimental parameters, the absolute values of electrical resistance achieved during different experiments can be directly compared only if those experiments were performed with the device installed on the same plant and operating at the same temperature, pressure and flow rate.

For what concerns the Hot Trap, its capability of reducing Nitrogen concentration has been demonstrated, both when operated at 550 $^{\circ}\text{C}$ and at 600 $^{\circ}\text{C}$; at 600 $^{\circ}\text{C}$, in particular, the trap was able to reduce Nitrogen down to ~ 14 wppm, reducing it from ~ 56 wppm in about 1 week of purification, overcoming the apparent limit of ~ 30 wppm found at 550 $^{\circ}\text{C}$. Again, if in future experimentations Lithium samples with higher Nitrogen content will be available, it will be possible to verify the capability of the Trap to remove larger Nitrogen amounts and eventually define the kinetics of the gettering process.

It must finally be said that at the end of Lifus 6 scheduled activities it will be also possible to open both the Cold and the Hot Trap and inspect the interior of these tanks. In the case of the Cold Trap, solid particles possibly retained by the three dimensional mesh could be collected and analysed to roughly quantify their amount and verify their chemical nature; in the case of the Hot Trap, the Titanium getter will be instead removed to permit an inspection of its surface state and a better evaluation of its interaction with Nitrogen.

4 Riferimenti bibliografici

1. K. Natesan, "Influence of nonmetallic elements on the compatibility of structural materials with liquid alkali metals", *Journal of Nuclear Materials*, 115 (1983), 251-262
2. O.K. Chopra, D.L. Smith, "Influence of Temperature and Lithium purity on corrosion of ferrous alloys in a flowing lithium environment" *Journal of Nuclear Materials*, 141-143 (1986), 584-591
3. P.Favuzza, A.Antonelli, "Rapporto sulla procedura offline di analisi chimica della concentrazione di azoto in litio", Report Rds/2013/125, settembre 2013
4. P.Favuzza, "Rapporto sulla validazione del sistema di purificazione del litio all'interno di Lifus 6 e del sistema di monitoring online di tali impurezze", Report Rds/2013/126, settembre 2013
5. P.Favuzza, A.Antonelli, R.Traversi, M.Severi, "Validazione sperimentale della procedura di analisi offline della purezza del litio e stima della cinetica di purificazione", Report Rds/2013/209, settembre 2014
6. M.G. Down, Proc. 2nd. Int. Conf. Liquid Metals Technology and Energy Production, Richland, Wash., Vol. 2 (1980), 14-16
7. P. Favuzza, A.Aiello, A.Tincani, M. Muzzarelli, "Engineering Design Report of Lifus 6 Purification System" IFMIF Deliverable LF 4.4.1, February 2014
8. P.Favuzza, S.Mannori "Acceptance Test Report of the Lifus 6 Purification System" IFMIF Deliverable LF 4.4.3, May 2015
9. A.S. Bailey, D.H. Gregory and P.Hubberstey "Design, technical specification and proof of concept of the nitrogen resistivity meter" Tech. report N°5 for contract proposal N°64 (2004)
10. G.K. Creffrey, M.G. Down and R.J. Pulham, "Electrical Resistivity of Liquid and Solid Lithium", *J. Chem. Soc., Dalton Trans*, (1974), 2325-2329
11. P.Favuzza, A.Antonelli, M.Cuzzani, G.Fasano, S.Mannori, "Risultati relativi alla prima fase di purificazione del Litio circolante all'interno dell'impianto Lifus 6 e verifica ed ottimizzazione contestuale del suo funzionamento", Report Rds/2014/055, settembre 2015
12. C.Y.Ho, T.K.Chu, "Electrical resistivity and thermal conductivity of nine selected Aisi stainless steels", *Cindas Report 45*, September 1977

5 Abbreviazioni ed acronimi

AC	Aircooler
C_x	Concentration of the X element
CT	Cold Trap
EMP	Electromagnetic Pump
EVEDA	Engineering Validation and Engineering Design Activities
HT	Hot Trap
IFMIF	International Fusion Materials Irradiation Facility
PA	Procurement Arrangement
R	Electrical Resistance
RAFM	Reduced Activation Ferritic Martensitic
RM	Resistivity Meter
Std. dev.	Standard Deviation
T	Temperature
t	Time
wppm	Weight Parts per Million
ρ	Electrical Resistivity