



Ricerca di Sistema elettrico

Progettazione, realizzazione e test del dispositivo di pulizia per la rimozione di litio solido per il Target Assembly di IFMIF

Gioacchino Micciché, Fabrizio Frascati, Luciano Lorenzelli

PROGETTAZIONE, REALIZZAZIONE E TEST DEL DISPOSITIVO DI PULIZIA PER LA RIMOZIONE DI LITIO SOLIDO PER IL TARGET ASSEMBLY DI IFMIF.

Gioacchino Micciché ENEA Brasimone
Fabrizio Frascati ENEA Brasimone
Luciano Lorenzelli ENEA Brasimone

Settembre 2016

Report Ricerca di Sistema Elettrico

Accordo di Programma Ministero dello Sviluppo Economico - ENEA

Piano Annuale di Realizzazione 2015

Area: GENERAZIONE DI ENERGIA ELETTRICA CON BASSE EMISSIONI DI CARBONIO

Progetto: B.3.2 – Attività di Fisica della Fusione Complementari a ITER

Obiettivo: *B2 Forniture ed implementazioni comuni per sviluppo e qualifica di sistema di manipolazione remotizzata e della progettazione completa del target assembly di IFMIF*

Responsabile del Progetto: A. Pizzuto, ENEA

Indice

SOMMARIO.....	4
1 INTRODUCTION.....	5
2 DESIGN AND CONSTRUCTION OF THE CLEANING TOOL PROTOTYPE.....	5
2.1 MAIN REQUIREMENTS FOR THE DESIGN OF THE CLEANING TOOL.....	5
2.2 THE BASIC IDEA OF THE RIBBON CLEANING TOOL.....	6
2.3 DESIGN OF THE RIBBON CLEANING TOOL.....	6
2.4 RIBBON CLEANING TOOL PROTOTYPE AND INTEGRATION IN DRP.....	8
2.5 THE CONTROL SYSTEM OF THE CLEANING MACHINE AND ITS INTEGRATION IN DRP.....	12
2.6 RIBBON TOOL PREPARATION.....	13
2.7 CLEANING TOOL TUNING.....	13
3 TESTING OF THE CLEANING TOOL.....	14
3.1 PREPARATION OF THE TEST.....	15
3.2 TESTS EXECUTION.....	15
4 CONCLUSIONS.....	19
5 REFERENCES.....	19
6 ACRONYMS.....	19

Sommario

Il sommario contiene una breve sintesi del documento (200-500 parole) ed include eventuali conclusioni.

1 Introduction

The International Fusion Materials Facility (IFMIF) will be provided of a Lithium Target Assembly (TA) to generate the neutron flux required for the irradiation of samples material to be adopted for the construction of future fusion power plants. Two TA concepts were designed and investigated during the EVEDA phase : the Integral target (IT) and the Target based on the so called removable backplate. The first one has been developed in Japan while the other in Europe. This report deals only with the EU concept of the TA for IFMIF.

One of the most technically challenging activities of the IFMIF facility is the maintenance and the refurbishment of its components, and among these the TA appears to be critical since it is located in side of the Test and Target Cell (TTC) which is the most severe region of neutron irradiation. The EU TA design is based on a removable backplate[1,2], which is also the most heavily exposed component to the high neutron flux and, thus, its substitution is expected to be carried out at least every year, together the TA, if not more frequently. Then an effective and efficient remote handling (RH) replacement of the backplate and of TA becomes a precondition to fulfill the stringent requirement of IFMIF plant availability. The achievement of such high effectiveness of the remote handling operations to be performed requires the validation of the implemented maintenance procedures with the scope to evaluate their feasibility and potentials improvements.

The annual preventive maintenance of IFMIF plant, whose duration has been fixed in 20 days, during which the TA is substituted or refurbished is the main parameter to be fulfilled, and according to the RH maintenance strategy for IFMIF all maintenance operations for the TA have to be completed with 7 days[2]. To satisfy this ambitious requirement all maintenance procedures for the components to be maintained must be fully validated.

Among the maintenance operations to be performed for the refurbishment of the TA critical appears the cleaning of the surfaces, from solid lithium, that are in contact with the sealing system of Backplate of the TA.

To validate the cleaning operation a new tool have been designed, manufactured and tested. Description of this tool and outcomes of the experimental test campaign are given in this report.

The experimental test campaign has been performed in the Divertor Refurbishment Platform (DRP) facility at ENEA CR Brasimone.

2 Design and construction of the cleaning tool prototype

To validate the cleaning procedures for the removal of the lithium solid deposited on the surfaces of the interface frame of the TA a cleaning machine has been designed, manufactured and tested. This removal operation is performed thanks the high capability of the liquid solution adopted for dissolving the lithium. The developed machine is based on a simple concept: "Spray" the surfaces to be cleaned always with fresh dissolving solution. According to this concept the designed machine is based on a pre wet rotating tape

The cleaning operation of the supporting frame of the TA is considered critical for the following reasons:

- 1) The TA is installed in the TTC that is highly activated.
- 2) The space available is reduced;
- 3) The duration of this operation is expected very long and the end effector of the cleaning device is in contact with the surfaces to be cleaned.

The above mentioned topics entail that the final cleaning machine has to be designed by using rad-hard technology, that today is not fully available.

2.1 Main requirements for the design of the cleaning tool

The cleaning operation for the removal of lithium solid deposited on the frame support of the Target assembly of IFMIF is one of the most challenging maintenance operation. Sealing of the backplate, as well as of the connecting flanges, can be ensured only if the surfaces in contact with the gasket complies with the standards characteristics defined by the supplier. This means that after the annual operation

of IFMIF if the supporting frame of the backplate will be reused all the surface characteristics have to be reset to the original one.

According to this the following main requirements and technical specifications have been taken into account for the design of the cleaning tool:

- 1) To have the ability to remove any traces of lithium deposited in the surfaces;
- 2) Cleaning dripping is not allowed: no pollution is admitted in the area where the machine operates;
- 3) Cleaning solution must not contain water;
- 4) Minimum size: the size of the device has to be compatible with the space available for the execution of the cleaning task.
- 5) Remotely controllable: start and stop operations of the device must be performed from the control room

In addition the following requirements have been considered for the selection of the ribbon:

- 1) Robustness: during the cleaning operations no tears must occur to the tape;
- 2) Use of antiabrasive material: tape material does not provoke damages to the surfaces on which it operates;
- 3) High absorption capability and adequate capacity to release the solution.

2.2 The basic idea of the ribbon cleaning tool

The basic idea of the ribbon cleaning tool is based on the use of continuous ribbon that is driven to “clean” to “dirt” spool with a drive motor. A dispensing head add cleaning solution to the ribbon before the cleaning head.

A conceptual layout of this configuration of cleaning tool is shown in Fig. 1. Cleaning solution dispensing head is in blue while cleaning wheel is in red.

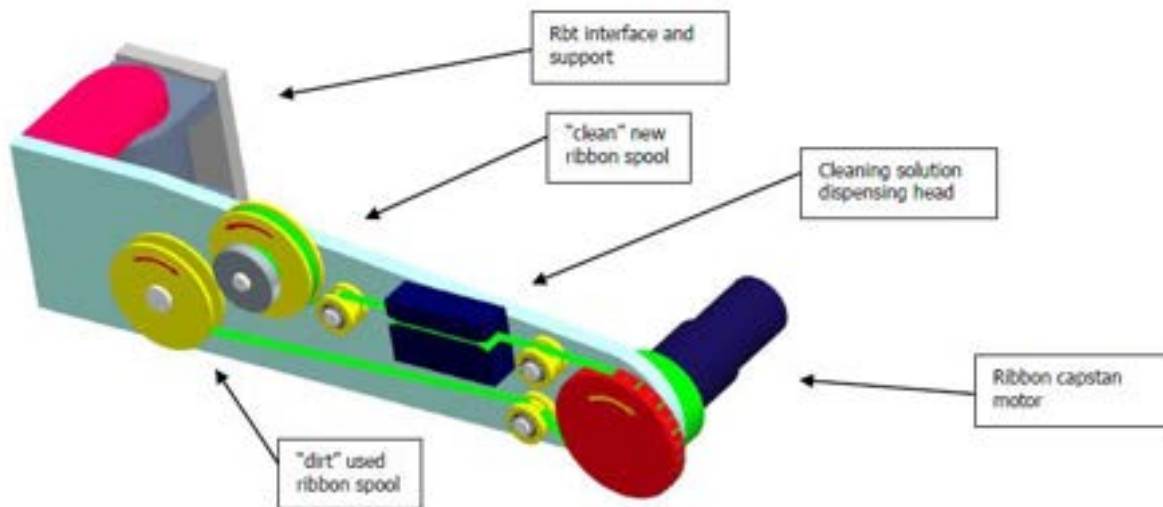

Fig. 1. Basic concept of the Cleaning tool

The main advantage of this configuration is that a virgin tape is always in contact with the surface to be cleaned and this allows that the cleaning surface is continuously kept clean, while the main drawback is that to keep the ribbon in place on the cleaning wheel the cleaning direction must always stay in the cleaning wheel plane. In particular no or very low transverse displacement is admitted, between the cleaning wheel plane and the plane surface to be cleaned, to avoid ribbon run out of the wheels.

2.3 Design of the Ribbon Cleaning tool

Starting from the above reported conceptual design a custom ribbon cleaning tool was developed. The reel to reel concept with a clean ribbon sprayed with cleaning solution was further developed and a 3D

model of its final arrangement is shown in Fig. 2. Here the same functional groups of the conceptual design are clearly identified.

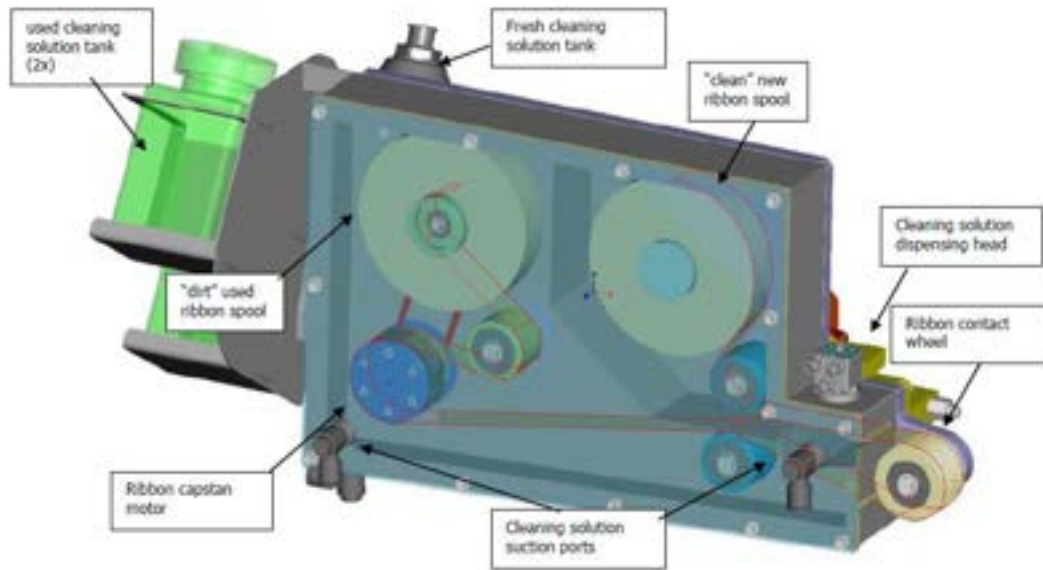

Fig. 2 3D Model of the cleaning tool prototype.

As shown in Fig. 2 the entire ribbon path is inside the machine body so to reduce as far as possible cleaning solution spillage. Furthermore two suction ports sets are located in the machine carter for recovering the unused cleaning solution.

The ribbon is pulled by the capstan motor where the ribbon is kept tensioned thanks to a friction clutch between the "used" reel and the capstan itself.

The "clean" ribbon reel is frictioned so to ensure an even ribbon tension all along its path.

Idle wheels are convex so to keep straight ribbon and the contact wheel as the capstan wheel have some surface features which increase the ribbon grip.

In Fig. 3 the CAD model of the cleaning tool is shown where dashed colored lines identify three different confined areas:

- The red area is considered dry and clean and is where the clean ribbon is loaded;
- The yellow area is where the solution is sprayed on the ribbon
- The magenta area is where the use and wet ribbon is stored

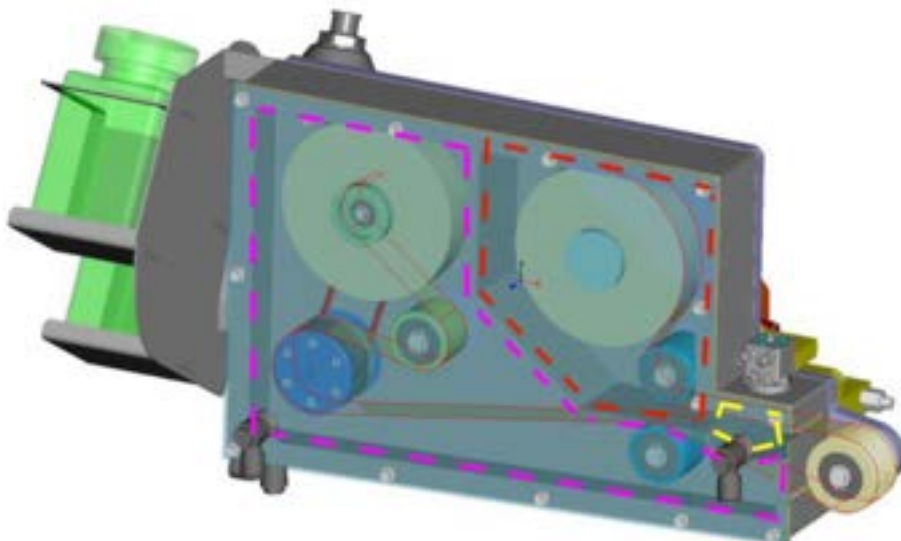

Fig. 3 3D Model of the cleaning tool prototype (confined areas)

The cleaning device is provided of three tanks:

- The cleaning solution pressurized tank that is filled with a solution of ethylene, acetic acid an hydrogen peroxide($\text{CH}_3 \text{CHOOH} + \text{CH}_3 \text{CH}_2 \text{OH}$) with ratio of 1:1:1. It supplies the cleaning solution to the dispensing head at the right pressure;
- The used cleaning tanks that collect any residual of solution by the two suction ports

The flow of the cleaning solution between the three tanks, the dispensing head and the suction ports is ensured by means a pneumatic circuit as shown in Fig. 4.

In the pneumatic diagram the main components are identified:

- “a” is the cleaning solution tank that is pressurized with the relief valve “pt”.
- Cleaning solution is then sprayed by switching the “sp” valve.
- Cleaning solution flow is then tuned by thanks to the relief valve “ps”.
- The “su” valve activates the two venture “v1” and “v2” that drains the solution from the suction ports “s1”, “s2” and “s3” to the two tanks “b1” and “b2”.

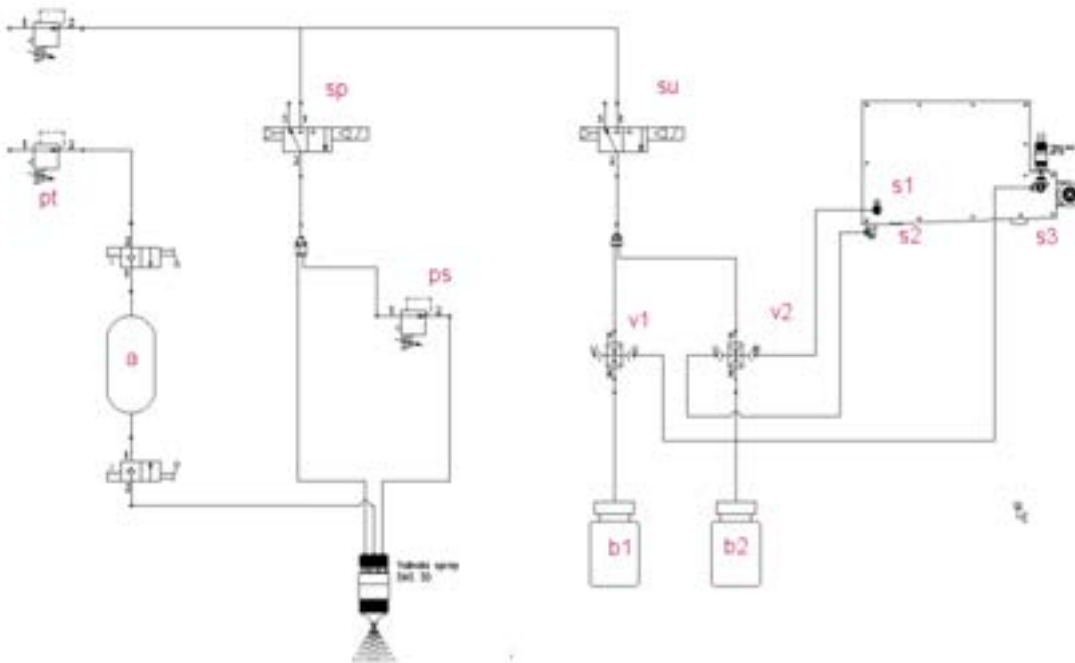

Fig. 3 3D Model of the cleaning tool prototype (Confined area)

One of the main parameter to be set up for the success of the cleaning operation is the rotation velocity of the ribbon wheel speed. It is clear that the rotational speed of this wheel has to be higher of the translational speed of the robotic arm that is used to move the cleaning machine all along the area to be cleaned. For this reason the ribbon nominal feeding speed is tuned at 40 mm/s (the max translational speed of the robotic arm is 30mm/s). A dimmer is located on the tool to reduce if needed the feeding speed.

2.4 Ribbon cleaning tool prototype and integration in DRP

In Figs. 5, 6 and 7 the manufactured prototype of the cleaning machine is shown.

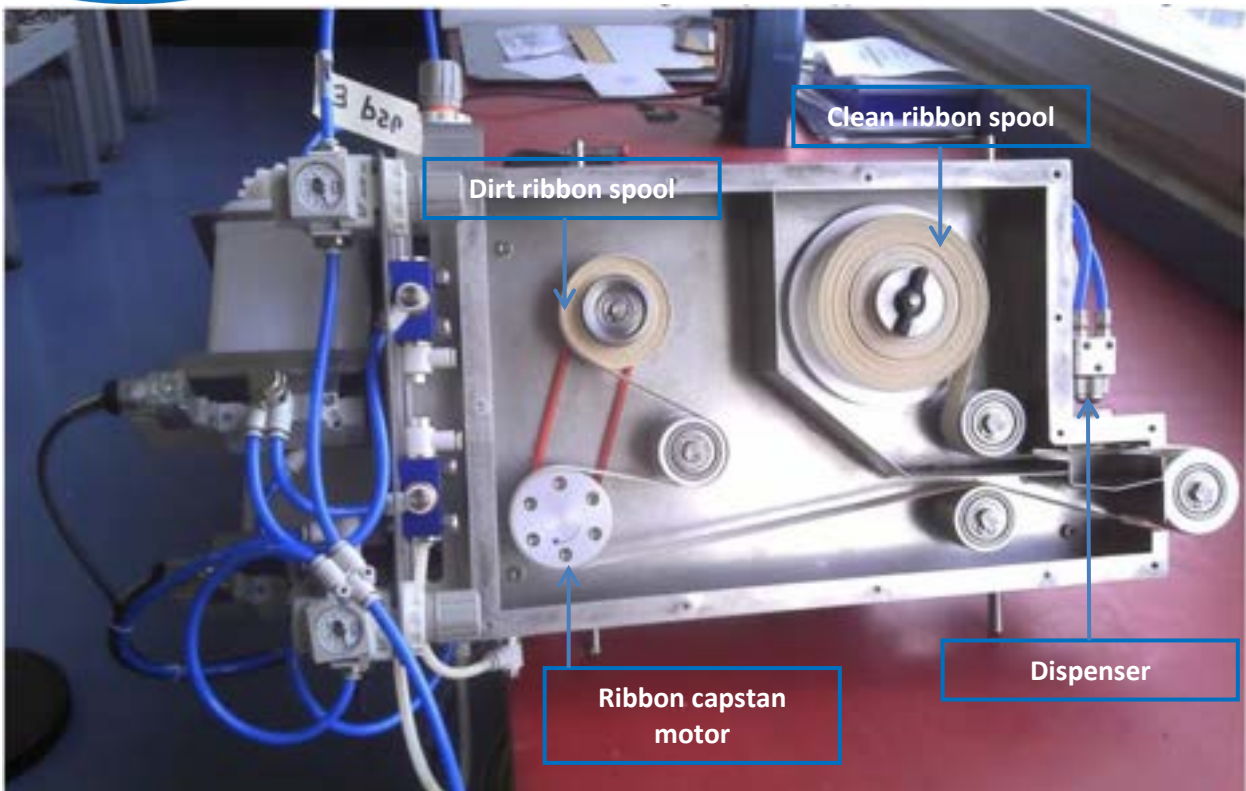

Fig. 5 Ribbon clean tool loading side (cover removed)

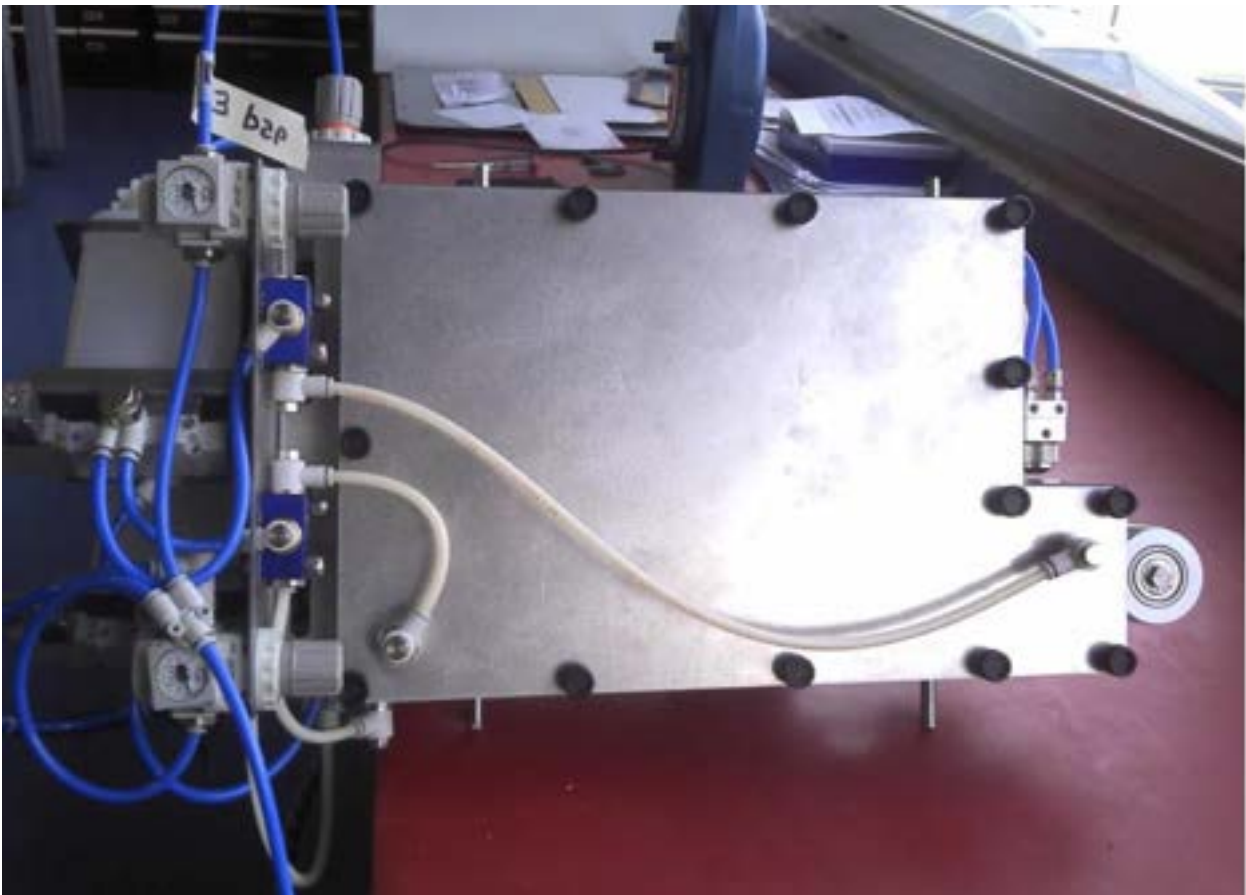

Fig. 6 Ribbon cleaning tool (cover in place)

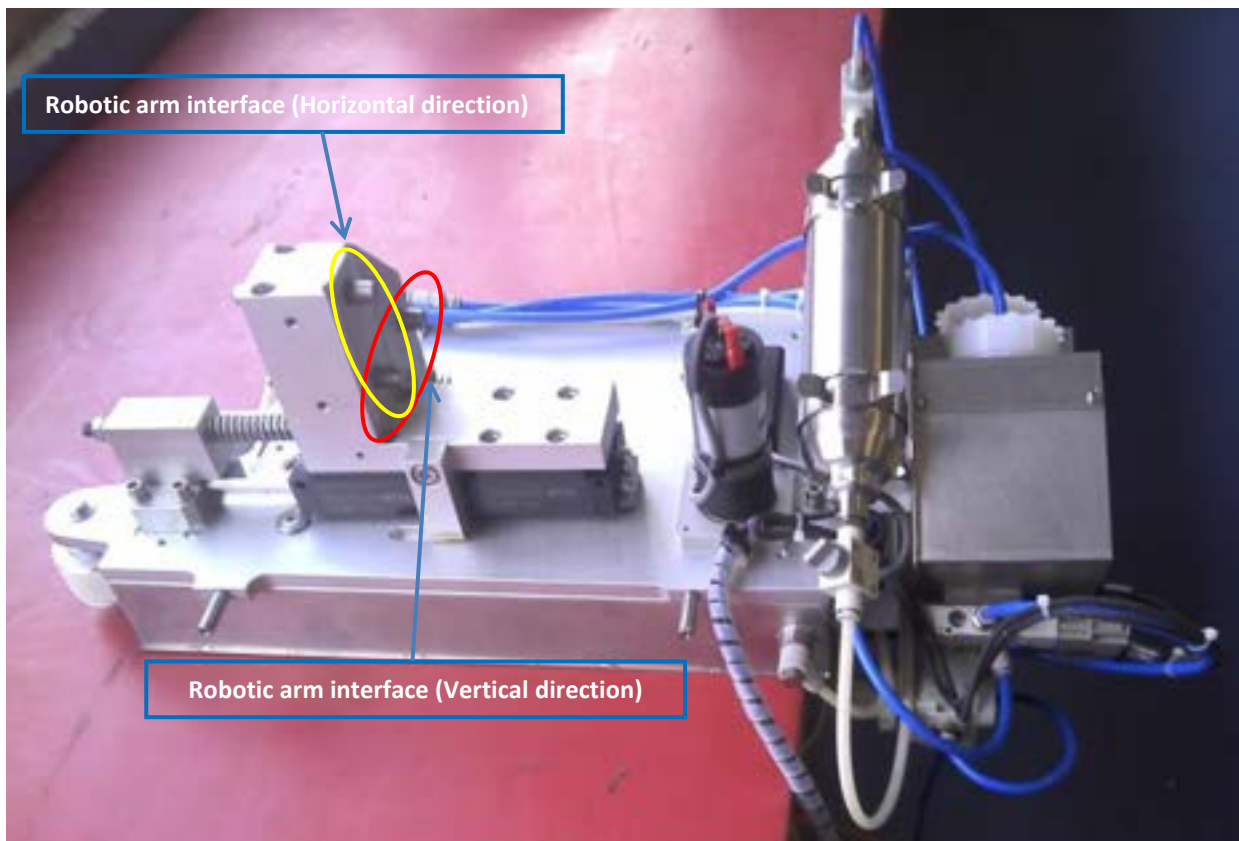

Fig. 7 Ribbon cleaning tools robot loading side

It should be noted, see Fig. 7, that the machine is provided with the interfaces for the gripper of the robotic arm that is used to keep in position and to move the machine while it is performing the cleaning operation. In particular the interfaces allow the manipulator to pick up the cleaning machine and clean the edge of the supporting frame in the vertical direction and in the horizontal one. To change the directions (horizontal and vertical) the robotic arm has to release the machine on the storage support and then change the pickup point. In Figs. 8,9, 10 and 11 a simulation of the handling of the cleaning machine during the operations are illustrated.

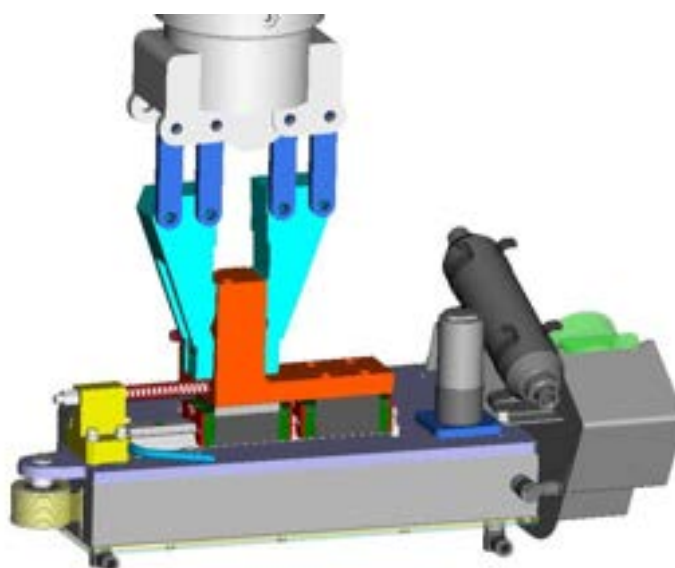

Fig. 8 Horizontal configuration of the cleaning machine

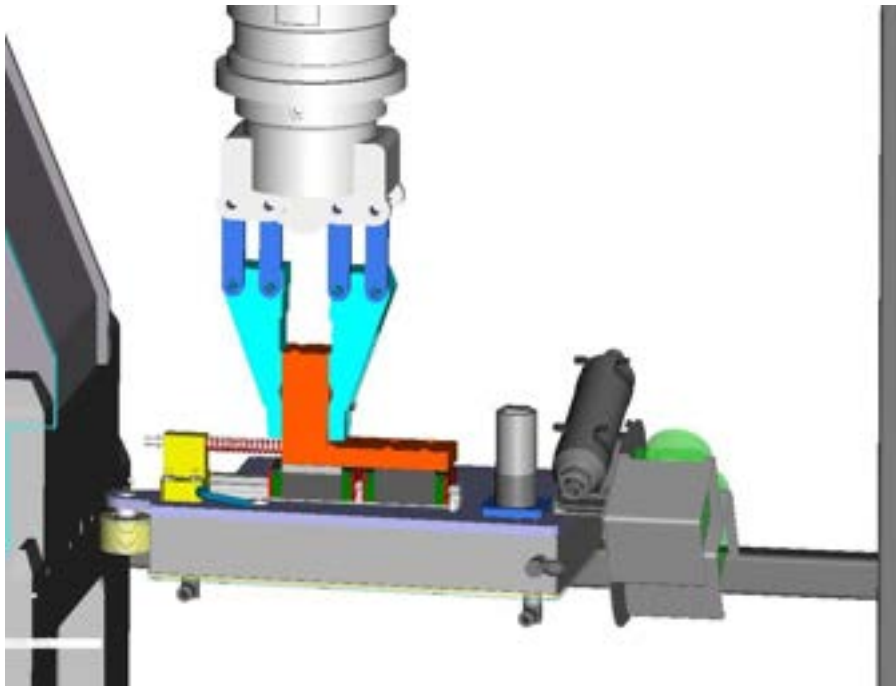

Fig. 9 Removal operation of lithium in the upper part of the supporting frame (horizontal direction)

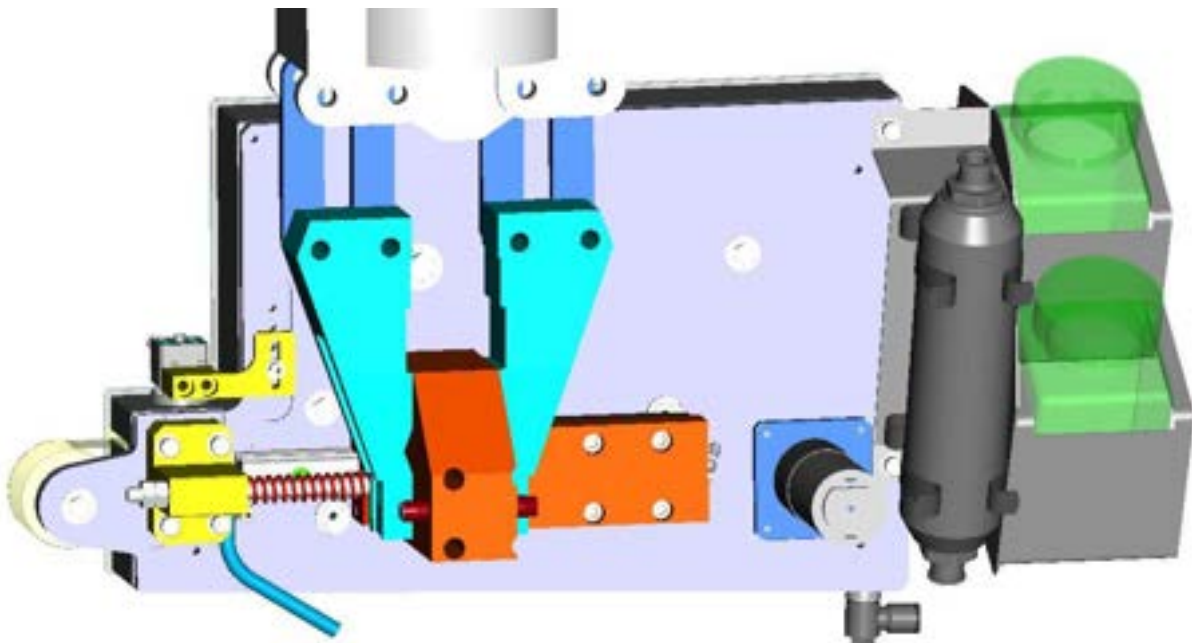

Fig. 10 Vertical configuration of the cleaning machine

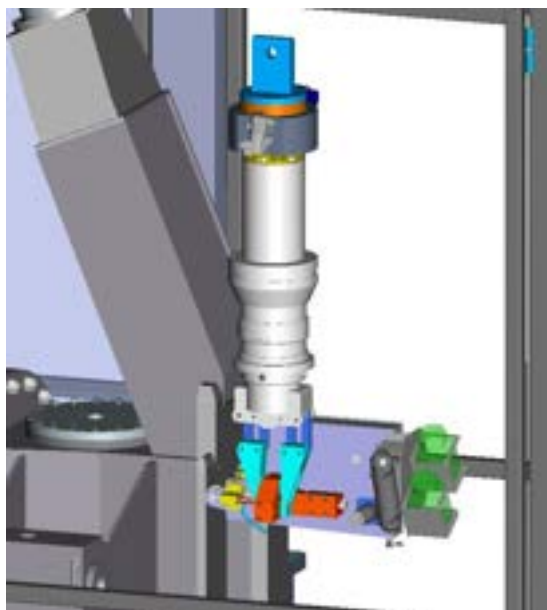

Fig. 11 Removal operation of lithium in the side part of the supporting frame (vertical direction)

2.5 The control system of the cleaning machine and its integration in DRP

For ribbon cleaning tool control the PLC SW already available in the DRP has been updated. Ribbon cleaning tool is connected both mechanically, pneumatically and electrically to the high payload DRP robotic arm.

Electrical integration of the cleaning device has been made connecting a local compressed air line and a CAN open terminal directly to the arm.

The motor and valves are controlled with the local CAN IO module located at the DRP arm shoulder level.

The PLC located in the DRP console has a dedicated menu for ribbon cleaning tool control.

Fig. 12 shows a screenshot of the added page on the PLC GUI specifically developed to control the cleaning tool.



Fig. 12 New PLC GUI integrated in the exiting control system of the DRP facility

The tool actuation sequence is below reported (the SW check the coherence of the tool status at every step).

Start of the clean tool:

- Enable drain tank aspiration (Suction On) ;

- Start ribbon motor(Motor On);
- Start solution spray(Spray On).

To stop the tool the sequence is the inverse of the one above reported.

2.6 Ribbon tool preparation

Two main operations have to be performed for the tool preparation:

- 1) Installation of the new tape
- 2) Filling the charging tank with the solution.
- 3) Drain the tank used for the used solution.

All these operations have to be repeated for each cleaning cycle. It is expected that one new ribbon reel is enough to cover one cycle of cleaning, as well as the charging tank has enough capacity to contain the solution to be used at least in one cleaning cycle.

Accordingly the main steps to prepare ribbon cleaning tool before use are below listed.

Installation of a new ribbon reel:

- Open the tool front panel;
- Insert the new ribbon reel on the “clean” shaft and route the ribbon inside the machine following the path shown in Fig. 13 (lock the ribbon end to the “dirt” shaft with some adhesive tape).
- Close the front panel

The preparation of the ribbon tool is easily performed hand on and take about 20 min. However it should be pointed out that in the real environment this operation cannot be performed hands on (To be confirmed) due to the dirt spool that will be contaminated. According a decontamination procedure has to be implemented.

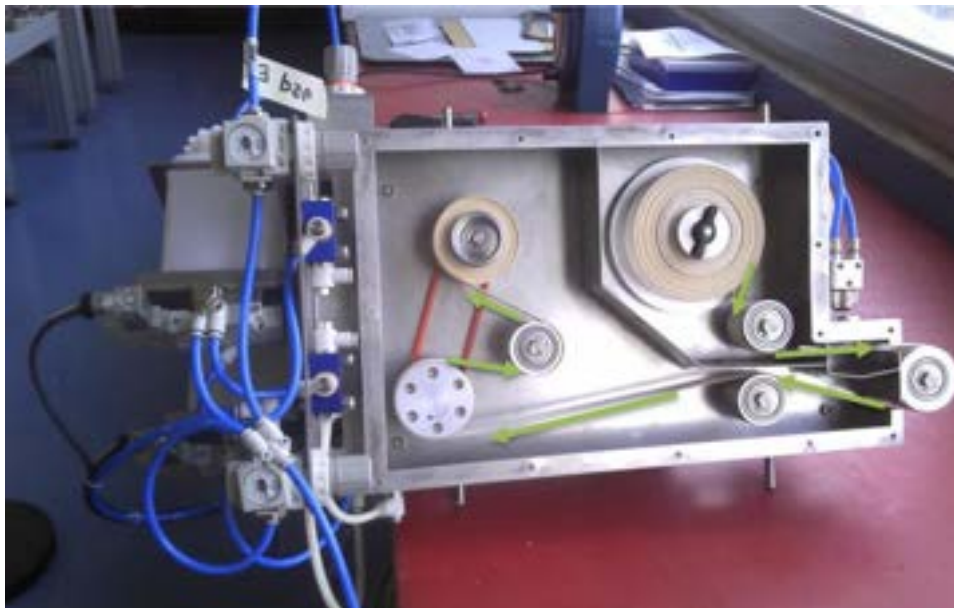

Fig. 13 Installation of a new ribbon reel of the cleaning machine

2.7 Cleaning tool tuning

The effectiveness of the cleaning tool depend from the correct configuration/calibration of the working parameters.

The following parameters have to be tuned to modify the tool performances:

- 1) Cleaning solution tank pressure with “pt” valve (MAX 3 bar);
- 2) Spray pressure with “ps” relief valve;
- 3) Spray head needle stroke (micrometer screw on the top of the dispensing head).

All these tuning operations are performed on board the machine.

3 Testing of the cleaning tool

The validation and testing of the manufactured cleaning tool has been carried out in the DRP facility. A full size prototype of the supporting frame of the backplate was used to verify the cleaning capability of the device. It should be pointed out that during the test, for safety reason, no lithium was used. To simulate the solid lithium deposited on the surface a film of molykote has been sprayed of the frame mockup. The supporting frame mock up used for the test is shown in Fig. 14.



Fig. 14 Full size mockup of the supporting frame for the backplate.

Ten cleaning tests have been carried out and for each test the cleaning times have been measured. In addition fulfillment of the following features were also observed:

- 1) Capability to complete one cleaning phase from “dirt” to “clean” with one ribbon reel;
- 2) Capability to complete one cleaning phase from “dirt” to “clean” with the solution contained in the pressurized tank.

The area to be cleaned is highlighted in yellow in Fig. 15. The surface to be cleaned is of about 26400 mm².

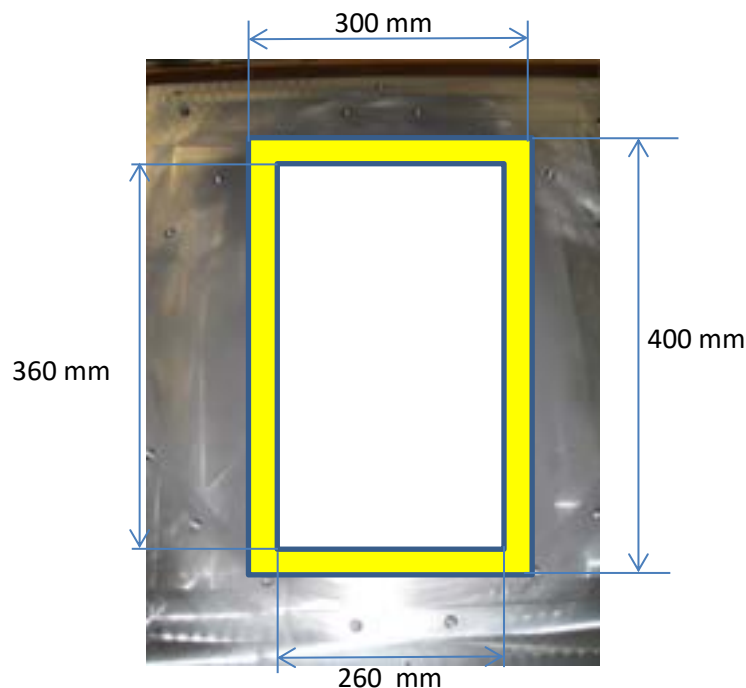

Fig. 15 Area to be cleaned in Yellow.

3.1 Preparation of the test

The preparation of the test campaign consists of three steps:

- 1) the loading of the new ribbon reel in cleaning machine. This operation is performed by using the procedure illustrated in the CH# 2.6 in this document;
- 2) the filling of the pressurized tanks and the draining of the two storage tanks;
- 3) the tuning of the cleaning machine parameters as described in the CH#2.7. At the beginning of the test flow pressure and speed of the motor were set up at the nominal values (i.e. 3 Bar and 40 mm/s).
- 4) finally the surface of frame support to be cleaned was sprayed to deposit a very thin layer of molykote (the expected thickness of the lithium layer is of the order of a few μm).

Fig. 16 Shows the frame mockup already sprayed with molykote



Fig. 16. Backplate support frame mockup sprayed with molykote

3.2 Tests Execution

Ten cleaning trials were performed. All occurred event were recorded together the intervention times for cleaning. Tuning of the cleaning machine operational parameters were modified during the trials to improve its performances. In particular after the completion of the first cleaning phase, carried out on the right side of the frame in vertical direction, speed of the motor has been changed.

In Fig. 17 the starting of the cleaning operation is shown. Here the cleaning machine is attached to the robotic arm which moves the machine in any directions and that push the ribbon against the surface to be cleaned. It should be pointed out that since no control of the pushing force is implemented, positioning of the end effector of the machine on the surface is performed with the help of the operator (see Fig. 18).



Fig. 17 Starting of cleaning operation

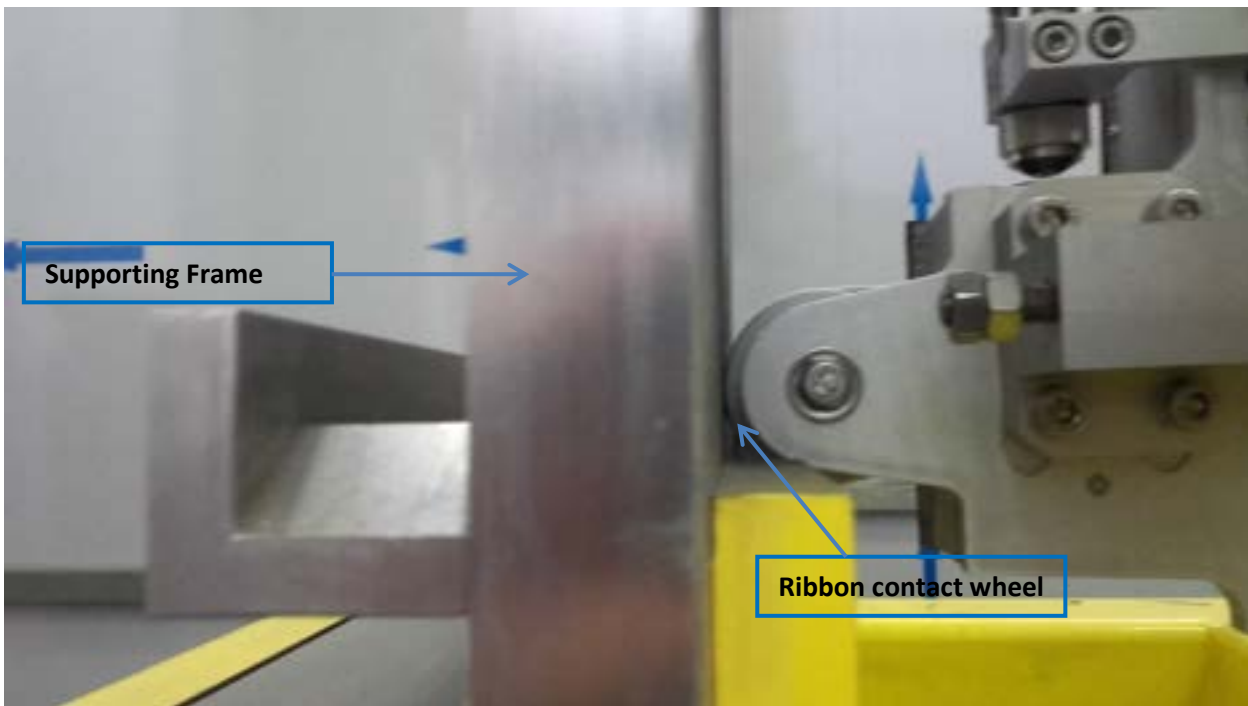

Fig. 18 Positioning of the end effector of the cleaning machine

The status of the surface after the first step of cleaning procedure is shown in Fig. 19. Here it is clear that molykote has not been removed homogeneously. This issue has been imputed to the speed velocities of the robotic arm and of the motor of the cleaning machine. According to this The speed of the robotic arm has been reduced to 15 mm/s and the rotational speed of the ribbon at 20mm/s. With this configuration cleaning operations proceeded better than before.

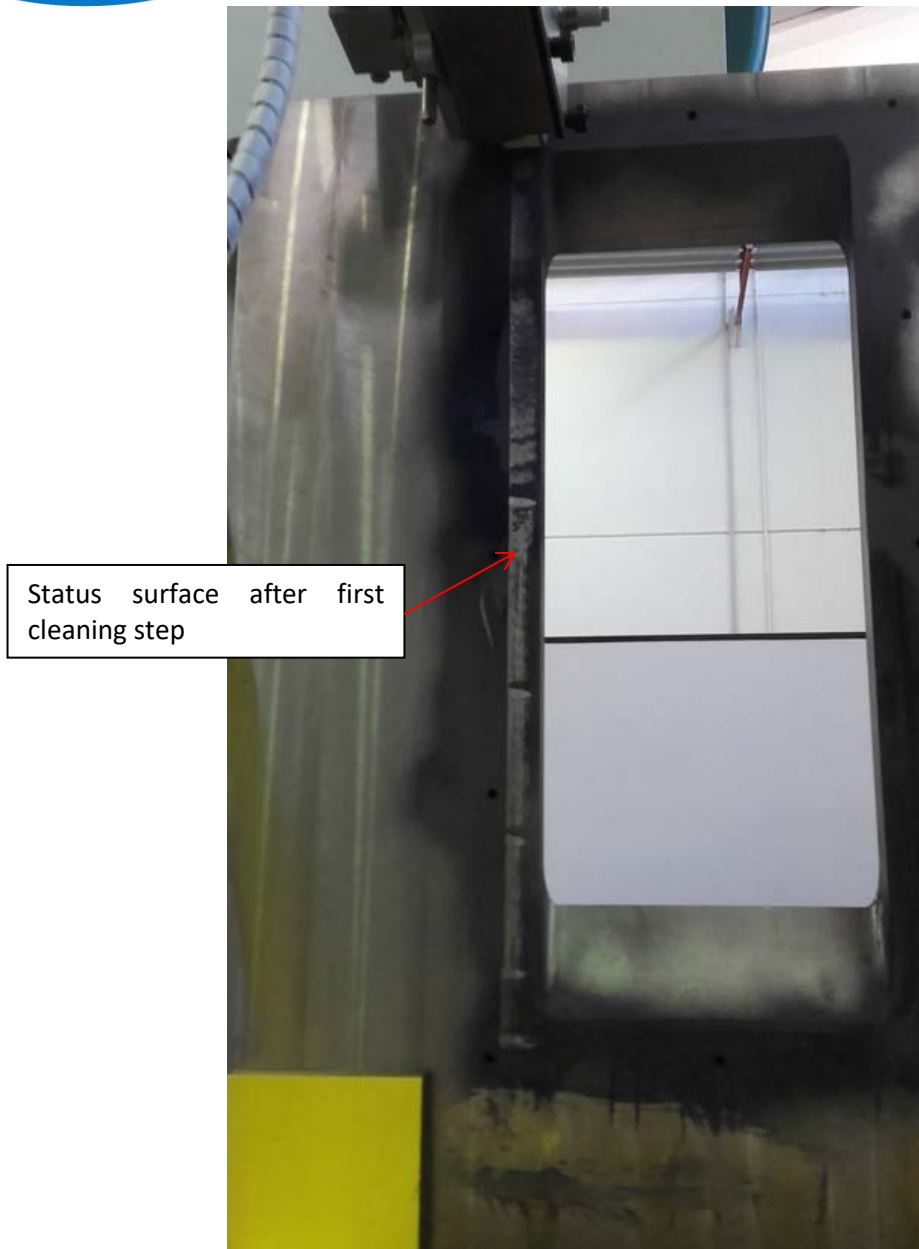

Fig. 19 Status of the frame surface after the first cleaning step

A few pictures of different cleaning steps are shown in Figs. 20, 21, 22 and 23. Five cleaning steps were required to achieve an acceptable degree of cleaning of the supporting frame. Dripping of the cleaning solution occurred in a few cases during the cleaning in the horizontal path in the lower side of the supporting frame. However the loose of solution due to the dripping was not relevant.

The visual inspection on the cleaned surface doesn't registered any damages to the surface. A summary of the results of the tests are included in the table 1.

Based on these results the average of number of cleaning steps, required to fully clean the surface, is of 4,5 steps while the average of the intervention time is of 210 min.

According to these results the maintenance intervention time for the refurbishment of the target assembly of IFMIF(i.e. the intervention time for the installation of the backplate) has been updated. In tab. 2 the new intervention times for the installation of the Backplate are reported. The main results in that case is that the backplate replacement of the TA of IFMIF can be replaced during the annual preventive maintenance period, whose duration has been established to be 7 working days. This time the intervention time for maintenance of the backplate includes also a realistic estimation of the duration of the cleaning operation.



Fig.20 2nd cleaning phase



Fig.21 3rd cleaning phase



Fig.22 Fourth cleaning phase



Fig.23 End cleaning phase

Tab. 1 Record of the test results.

Test N°	Number of steps	Time required (min)	Visual inspection	Note
1	5	235	Ok	
2	5	265	Ok	Small Dripping
3	5	220	Ok	
4	4	195	Ok	
5	4	190	Ok	
6	5	210	Ok	
7	4	190	Ok	
8	4	205	Ok	
9	5	210	Ok	Small Dripping
10	4	185	Ok	

Tab. 2 Maintenance Intervention time for the Backplate installation

Installation of the Bacplate	Cleaning of the supporting frame (min)	Backplate positioning (min)	Bolting of the skates (min) (*)	Bolting of screws (min) (*)	Intervention time (h:min)
Average time (10 tests)	210	26	8	6	10:06

(*) Bolting sequence: 20% of the nominal torque for each steps (five bolting steps)

4 Conclusions

On the Basis on the results of the preliminary tests performed the designed machine is suitable to perform the required cleaning operation via RH. Despite it was not tested in lithium, for safety reasons, it was able to clean the entire surface from this thin layer of molykote. However the cleaning solution adopted is the same used to dissolve lithium in an efficient way.

Further investigations and developments are still required, as follows:

- 1) final polishing of the surface, that could require an additional tool
- 2) design of the machine in Radhard version is mandatory
- 3) perform the tuning of the machine parameters from the control panel, and
- 4) the development of a new cleaning machine for the connecting flanges of the TA.

5 References

1. G. Miccichè, B. Riccardi, Design, manufacture and testing of the IFMIF lithium target bayonet concept, Fusion Engineering and design 75-79(2005) 807-811.
2. G. Miccichè, "Report on the design of the dummy target assembly mock up and the related ancillary systems for the experimental activities" , (ref. IDM: IFMIF –BA_D_23V67X rev. 1.0)
3. G. Miccichè, F. Frascati, L. Lorenzelli," Risultati delle prove di manutenzione remotizzata per il ricondizionamento e per la sostituzione del target assembly di IFMIF", Report RdS/PAR2013/210

6 Acronyms

BP Back Plate
DRP Divertor Test Platform

IFMIF International Fusion Materials Facility
RH Remote Handling
TA Target Assembly
TTC Target and Test Cell