



Ricerca di Sistema elettrico

Aggiornamento del layout dell'area denominata Access Cell per la manutenzione remotizzata dei componenti di IFMIF

Gioacchino Miccichè, Luciano Lorenzelli

AGGIORNAMENTO DEL LAYOUT DELL'AREA DENOMINATA ACCESS CELL PER LA MANUTENZIONE REMOTIZZATA DEI COMPONENTI DI IFMIF

Gioacchino Miccichè, Luciano Lorenzelli (ENEA)

Settembre 2017

Report Ricerca di Sistema Elettrico

Accordo di Programma Ministero dello Sviluppo Economico - ENEA

Piano Annuale di Realizzazione 2016

Area: GENERAZIONE DI ENERGIA ELETTRICA CON BASSE EMISSIONI DI CARBONIO

Progetto: B.3.2 – Attività di Fisica della Fusione Complementari a ITER

Obiettivo: *Progettazione e qualifica ingegneristica del target IFMIF – subtask b2. Forniture ed implementazioni comuni per sviluppo e qualifica di sistema di manipolazione remotizzata e della progettazione completa del target assembly di IFMIF*

Responsabile del Progetto: A. Pizzuto, ENEA

Si ringrazia l'Ing. Daniele Martelli dell'Università di Pisa per il supporto fornito nella modellazione 3D del nuovo layout dell'AC di IFMIF.

Indice

ABSTRACT	4
1 INTRODUCTION.....	5
2 THE PRESENT AC DESIGN OF IFMIF	5
2.1 PROPOSAL FOR A NEW CONFIGURATION OF THE AC OF IFMIF	7
2.1.1 <i>Main modifications of the AC</i>	7
2.1.2 <i>Sizing of the AC</i>	8
2.1.3 <i>Modification of the RHS</i>	9
2.1.4 <i>Decontamination and maintenance area for cranes and rails</i>	11
2.1.5 <i>Modifications of the Surrounding areas</i>	13
3 CONCLUSIONS	14
4 REFERENCES	14
5 ACRONIMS	15

Abstract

The International Fusion Materials Irradiation Facility (IFMIF) is a demanding facility in terms of systems reliability and plant availability. Each system of DONES is designed to guarantee an availability of more than 90% to achieve the goal of an availability of 70% for IFMIF plant. According to this, the systems must be monitored, inspected and maintained so that they function as per design. In IFMIF due to the neutron activation there are several components, like the Target Assembly (TA) and the Test Modules (TMs) and those of the Accelerator Systems as well, whose maintenance is considered critical and that can compromise the regular functioning of the plant.

Maintenance for critical components installed in the Test Facility (TF) and in the Lithium Facility (LF) will be performed in a dedicated area, namely Access Cell (AC), provided with all Remote Handling Equipment (RHE) and tooling to be used for the execution of the remote handling maintenance tasks.

A new proposal for the layout and configuration of this area has been conceived taking into account almost all the maintenance to be performed in the TC and in the Accelerator Facility (AF) as well. The new AC concept is based on a T shape covering also two additional areas: the Target Interface Room (TIR) and the Radiation Isolation Room (RIR). This extension allows to perform all the maintenance from the same area and working out in parallel.

1 Introduction

The International Fusion Materials Irradiation Facility (IFMIF) is a demanding facility in terms of systems reliability and plant availability. Each system of IFMIF is designed to guarantee an availability of more than 90% to achieve the goal of an availability of 70% for IFMIF plant[1]. According to this, the systems must be monitored, inspected and maintained so that they function as per design. In IFMIF, due to the neutron activation there are several components, like the Target Assembly (TA) and the Test Modules (TMs) and those of the Accelerator Systems as well, whose maintenance is considered critical and that can compromise the regular functioning of the plant.

Maintenance for critical components installed in the TF and in the AF will be performed in a dedicated area, namely Access Cell (AC), provided with all RHE and tooling to be used for the execution of the remote handling maintenance tasks.

A new proposal for the layout and configuration of this area has been conceived taking into account almost all the maintenance to be performed in the TC and in the AF. The new AC concept is based on a T shape layout covering also two additional areas: the TIR and the RIR. This extension allows to perform all the maintenance from the same area and working out in parallel. This latter topic is considered of preminent importance to fulfill one of the most challenging requirements of the maintenance duration that has been fixed in 20 working days per year.

This document deals with a review of the AC configuration of IFMIF. After a brief description of the present AC configuration a detailed description of the new layout of this area, including the surrounding areas, is given.

2 The present AC Design of IFMIF

Almost all the remote handling maintenance of IFMIF components, belonging to TF and to LF will be performed from the AC of the TF. List of components to be maintained from the AC is reported in the Tabs. 1, 2.

Tab. 1 List of components to be maintained in the LF

Lithium System					
Component	Zone	Zone classification	Frequency of maintenance (year)	Class of component	Maintenance Type
Target assembly	TC	Prohibited	2	1 st	RH
Removable Backplate	TC	Prohibited	1 (TBC)	1 st	RH
FDSs	TC	Prohibited	Not planned	3 rd	RH
Cardan Join	TC	Prohibited	Not planned	3 rd	R RH HRH
Quench tank	TC	Prohibited	Not planned	3 rd	RH
Beam Duct	TC	Prohibited	Not planned	3 rd	RH
Plugs	TC/Li loop	Prohibited	Not planned	3 rd	RH
Inlet pipe(vertical part)	TC	Prohibited	Not planned	3 rd	RH

Tab. 2 List of components to be maintained in the TF

Test System					
Component	Zone	Zone classification	Frequency of maintenance (year)	Class of component	Maintenance Type
TTC covers	Access cell	Restricted	1	1 st	RH(*)
Seal of the TTC Vessel Cover	Access cell	Restricted	1	1 st	RH(*)
Upper Top Shielding Plugs	Access cell	Restricted	1	1 st	RH(*)
Lower Shielding Plug	Test Cell	Prohibited	1	1 st	RH
TC liner	Test cell	Prohibited	Not scheduled	3 rd	RH
PCPs	Test Cell	Prohibited	Non scheduled	3 rd	RH
High Flux Test Module (TM)	Test Cell	Prohibited	1	1 st	RH
Medium Flux Test Module (MFTM)	Test Cell	Prohibited	1	1 st	RH
Low Flux Test Module (LFTM)	Test Cell	Prohibited	1	1 st	RH

The present design of the AC of IFMIF is illustrated in Fig. 1. It includes two cranes: the Access Cell Mast Crane (ACMC) and the Heavy Rope Overhead Crane (HROC). The ACMC is provided of a telescopic mast to support and locate the several end effectors to be used for the maintenance of components in the TC. The HROC is designed to transfer heavy components, weighting several tens of tons, in the area where the TC is located. In addition two arms located sideways to the TC (not include in FIG. 1) cooperate with the other RHE for the maintenance of in-TC components. However this configuration is useful only for the maintenance of components located in the TC but for other components, located in areas adjacent to the TC, requiring regular preventive maintenance, an independent set of RHE needs to be implemented. This entails additional costs, several common RHE and tooling have to be duplicated, and an increase of the complexity of the control system for the RHS of IFMIF. In addition it was observed that maintenance of the RHE in the AC was quite impossible with the present configuration.

A proposal for a new layout and organization of the AC has been proposed and the main outcomes of this activity are discussed in the next.

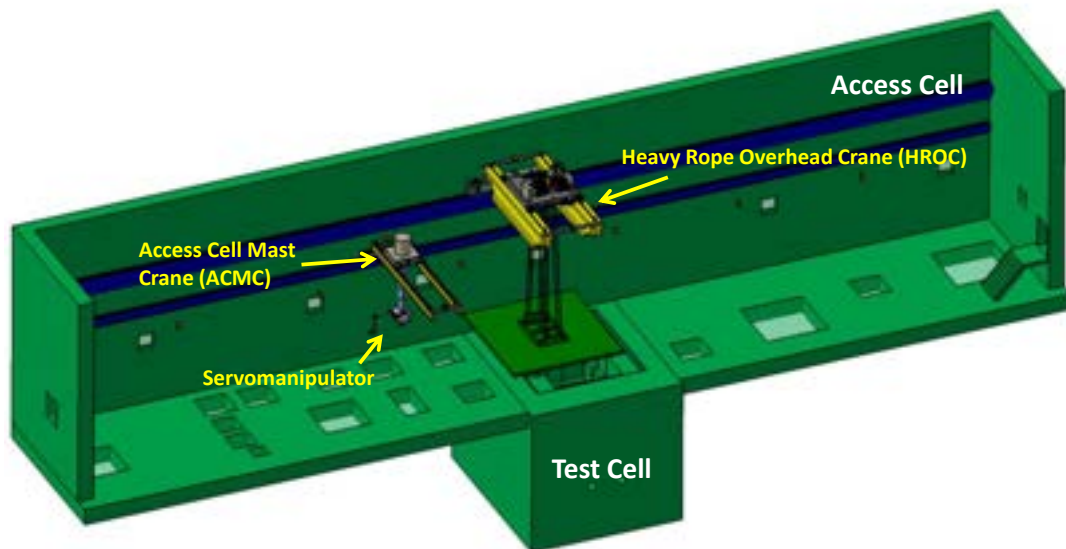

Fig. 1–Section of Access Cell with the two cranes installed

2.1 Proposal for a new configuration of the AC of IFMIF

The main requirement for the new AC configuration is to cover also the maintenance to be performed for components in the AF and in particular components installed in the TIR and in the RIR, both located at the end of the High energy Beam Tube (HEBT) of the accelerator.

2.1.1 Main modifications of the AC

The new AC concept is based on a T shape layout. It is located just above the TC, the TIR and RIR areas, and is designed to accommodate all the RHE and tools to be used during the RH maintenance tasks. It is sized to temporary store also all removable components, like the Test Cell Cover Plate (TCCP), the two TC shielding plugs (USP and LSP), while the TC is open, as well as for the shielding plugs of the hatches of the TIR and the RIR.

An overview of the NEW AC plant is given in Fig. 2.

The main modifications introduced by this new concept are:

- 1) Extension of the AC to cover the TIR/RIR area;
- 2) A couple of rails placed in the longest side of the AC
- 3) Two pair of rails placed on the extension of the AC
- 4) Maintenance and decontamination area for the RHE
- 5) Only one loading station (in the previous design there were two loading stations)
- 6) Only two hatches for the communications with the Storage room and the Irradiating Waste Treatment Cell (IWTC).

In addition slightly modifications to the surrounding areas to the AC were introduced.

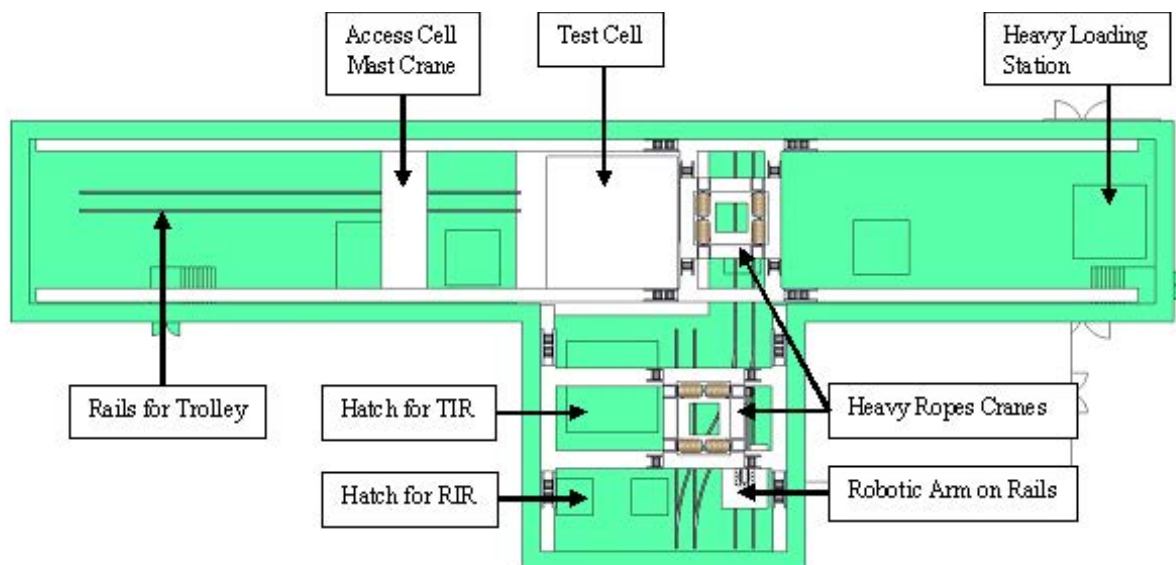

Fig. 2 Top view of the AC configuration

2.1.2 Sizing of the AC

Sizing of the AC takes into account the flow of materials in the AC itself during maintenance.

This AC configuration allows to perform the following maintenance tasks:

- Opening and closing of the TC including plug/unplug of electrical and cooling pipes connections
- High Flux Test Module (HFTM) exchange and its transportation to the IWTC for its dismantling
- TA exchange and its transportation to the IWTC for its dismantling
- TIR and RIR components replacement, like: vacuum pumps, valves, bellows, collimator and diagnostics.

In addition, exceptionally, also RH operations on components belonging to the 3rd class could be required, like the exchange of:

- The Interface Shielding Plugs (ISP) for the lithium inlet and outlet pipes to the TC
- The steel framework double liner of the TC
- The cooled walls of the TC
- The five Piping and Cabling Plug (PCPs)
- The TA positioning and support structure
- The Quench Tank (QT)

In Fig. 3 a plan view of the AC at the start time of the maintenance process is given. As it is shown, the new AC it is able to temporary store all removable plugs, including the storage of tooling. In addition flow of materials, like new TA and HFTM as well as the used one, can be easily managed.

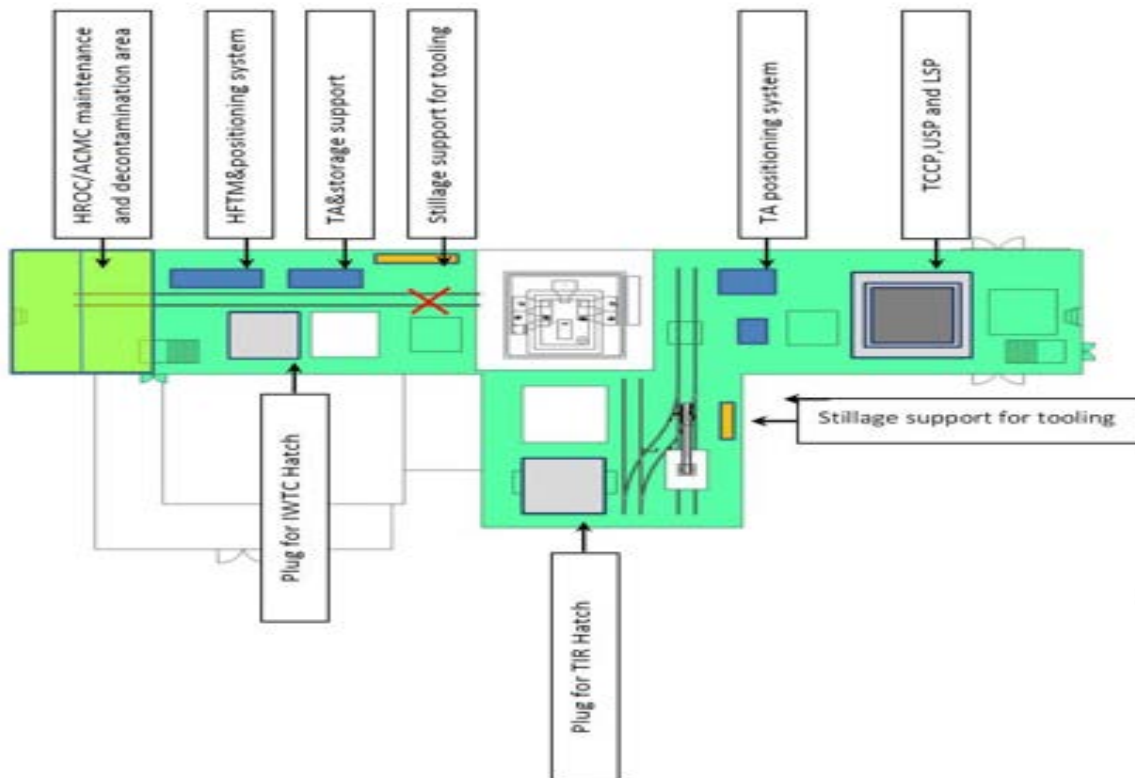

The accomplishment of all maintenance tasks entailed also the modifications of the RHS in the AC, that is briefly discussed in the next.

2.1.3 Modification of the RHS

The remote handling activities required for the maintenance of components installed in the TC, in the TIR and in RIR foresee the use of a number of common equipment and tools. Almost all equipment needed for the RH activities will be special purpose, hence not commercially available or at least based on commercial products requiring modifications. A preliminary list of equipment and tools that will be used in this context, including the expected maintenance tasks to be performed by each of them, is reported in Tab. 3. Equipment and devices listed in this table are related to maintenance of components belonging to the 1st class while it doesn't include those to be used for components of the 3rd class. According to the new AC organization, in Tab. 3 the new RHE and tooling required for the maintenance of the TIR and the RIR components are highlighted in green.

It should be pointed out that the list doesn't take into account of RHE and tooling for the accomplishment of the maintenance tasks required by the TC itself, like exchange of the cooled walls, because the design of the modifications to be implemented for the new TC concept is still ongoing, as well as all the equipment to be provided for the decontamination and maintenance of the cranes installed in the AC. However the listed one are fully consistent with the preventive maintenance requirements of IFMIF.

Tab. 3 Preliminary RHS in the AC of IFMIF

Remote Handling System	Maintenance Task	Maintenance Operation
RH equipment for the TS		
Heavy Ropes Crane_1	Open/close the TC	Removal/installtion of the TCCP, USP and LSP + plugs
Access Cell Mast Crane	TA+HFTM Exchange	Bring tooling inside the TC
Robotic Arm on Rail	TA+HFTM Exchange	Bring tooling inside the TC
Trolley for plugs transportation	Move plugs in the AC	Move plugs in storage position and vice versa
Lifting Frame for TCCP	Opening/closing TC	Pick up the TCCP
Lifting Frame for USP and LSP	Opening/closing TC	Pick up the USP/LSP
Positioning system for HFTM	HFTM replacement	HFTM precise positioning
Support for HFTM	HFTM replacement	Temporary storage of the new HFTM
Tooling for HFTM	HFTM replacement	Plug/unplug connectors and pipes
Support structure for tooling	NONE	NONE
Camera System	Support operators in the maintenance tasks	Provide view of the execution of the maintenance operations
RH equipment for LS		
Parallel Kinematics Manipulator	TA replacement	TA positioning
Robotic Arm for TA	TA replacement	Bring tooling inside the TC
Cleaning machine	TA installation	Cleaning of the connecting flanges
Lifting frame for TA	TA replacement	TA positioning
Inspection System	TA installation	Inspection of the flanges
Bolting Tools	TA replacement	Screw/unscrew the FDS
Temporary support for TA	TA replacement	Temporary storage of the new TA
Testing machine (vacuum pump and leak detection measurement)	TA installation	Final acceptance tests for the new target once installed
RH equipment for the AS (TIR)		
Heavy Ropes Crane_2	Open/close the TIR	Removal/installation of the plug of the hatches of TIR and RIR
Robotic Mast Arm (deployed in the TIR)	Replacement of beam line components	Connection/disconnection of components
Lifting system (integrated in the RAR)	Pump replacement	Lifting and lowering of components
Tooling	Pump replacement	Bolting/unbolting FDS
Camera system		Provide views of the execution of the maintenance operations

An open 3D view of the new AC with the main RHE is shown on Fig. 4.

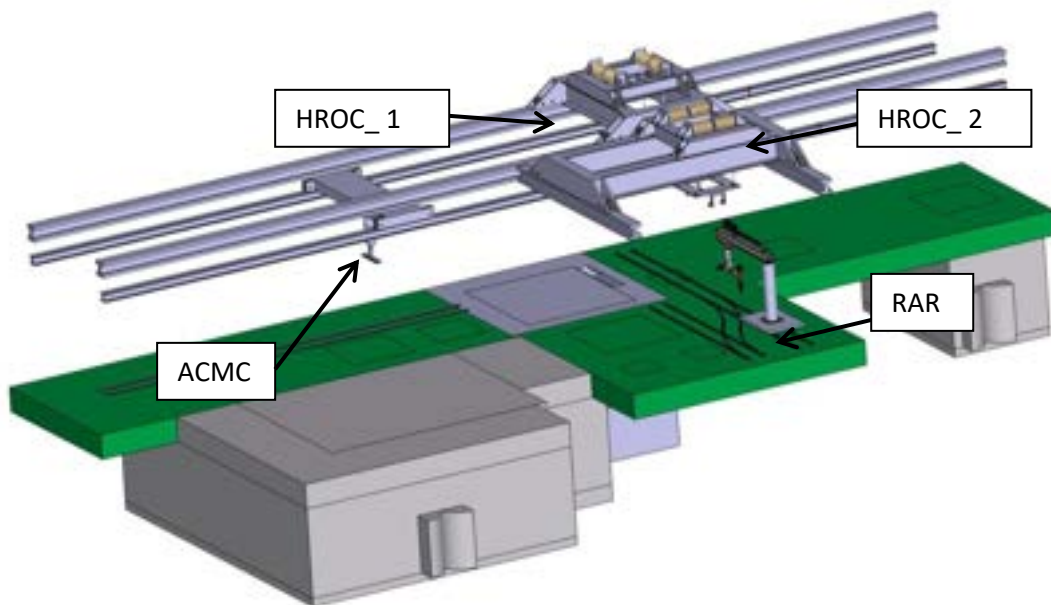

Fig. 4 Open view of the AC configuration

The RHS of the AC has been updated with an additional HROC_2 which serves the extension of the AC over the TIR and the RIR area and with a Robotic Arm on Rails (RAR) that can run between the TIR/RIR area and the TC area. This latter robotic device is used for the preventive maintenance and in case of rescue procedure as well.

2.1.4 Decontamination and maintenance area for cranes and rails

To allow the maintenance of the HROC and of the ACMC , the AC has been divided in three volumes as shown in Fig. 5 .

Room number 1 is dedicated to the preventive and corrective maintenance operations for the cranes , room number 2 is devoted to the cranes decontamination. The position of the floor of room 1 and 2 is to be defined according to the dimensions of the cranes (not yet specified) installed in the AC. Room 1 and 2 will be provided of sliding doors to separate the decontamination area from the AC and from the maintenance area (see Fig. 6).

Moreover, on the floor of the AC a series of trolley rails are foreseen as shown in 5. Rails introduced on the left side of the AC are considered for the transportation of components in the longest side of the AC, while the rails positioned on the right side of the AC are considered for transport of incoming components from the TIR/RIR area (see Fig. 7).

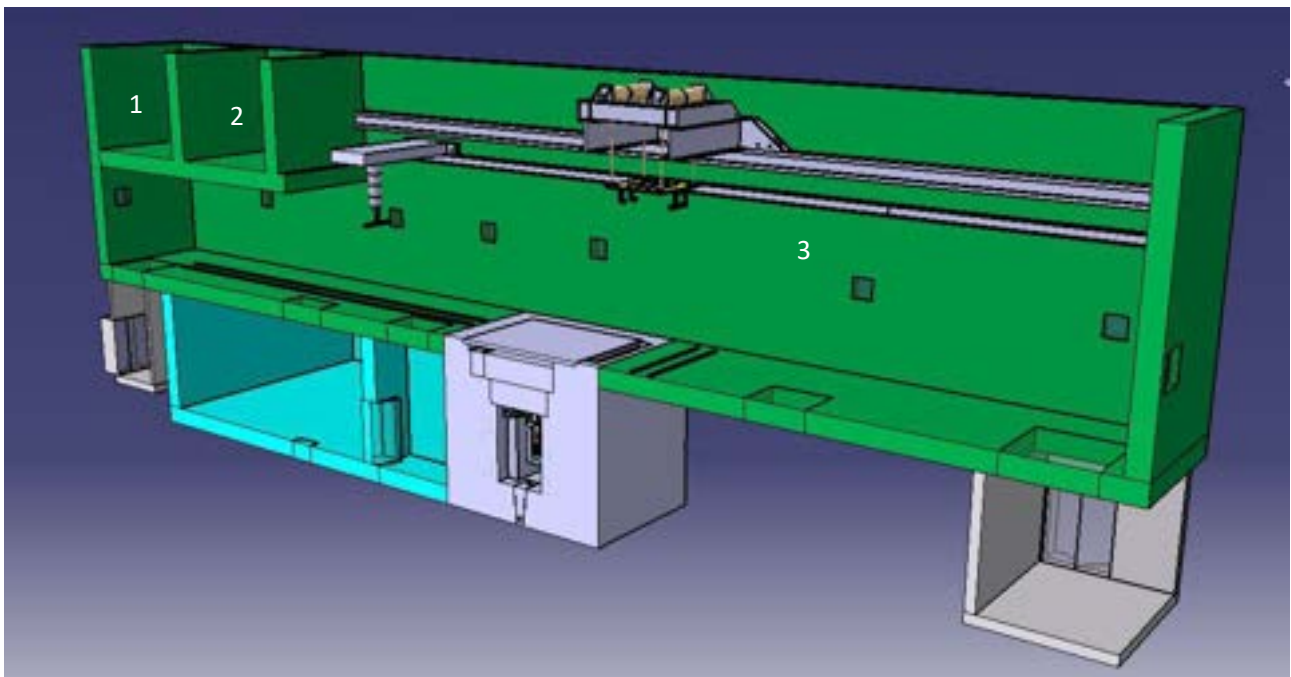

Fig. 5 Areas included in the new AC layout

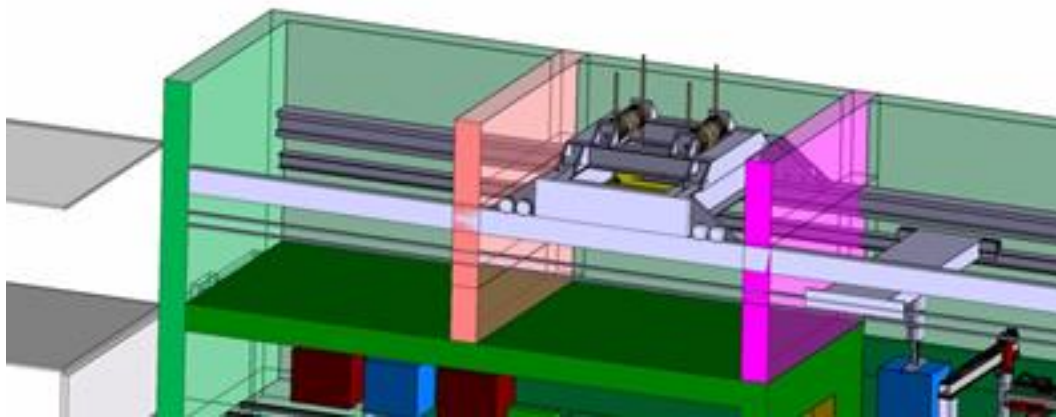

Fig. 6 Decontamination and maintenance areas for Cranes

Modifications introduced in the extension of the AC (this part of IFMIF building in the past was the High-Bay Hot cell) are depicted in Fig. 7. In particular, the floor of the High-Bay Hot Cell is lowered to the same level of the AC. This modification allows to connect the AC and the High-Bay with rails for handling of components coming from the High-Bay.

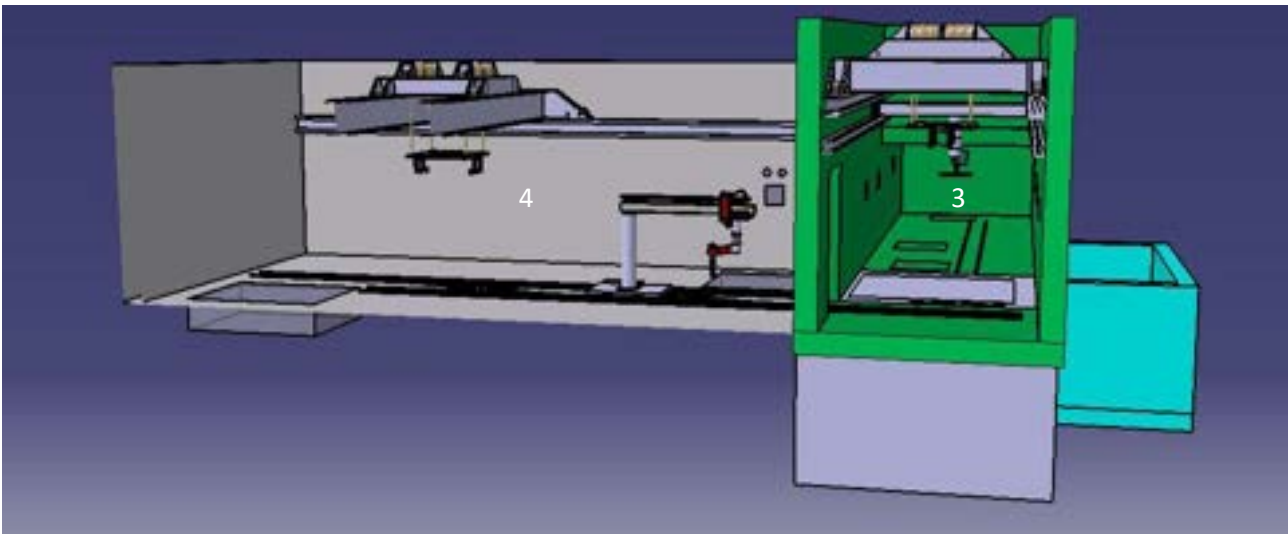

Fig. 7 AC modifications (Section view)

2.1.5 Modifications of the Surrounding areas

Main modifications of the surrounding areas to the AC are shown in Fig. 8. In particular the following area have been introduced/modified:

- 1) A temporary storage area for used components (7). This area is used to store components coming from the TC prior the dismantling process starts.
- 2) The Irradiating Waste Treatment Cell (IWTC) (6): dimension of this room has been increased to allow also dismantling operations of critical components;
- 3) The light Components loading station is suppressed, while the Heavy components loading station(8) is kept.

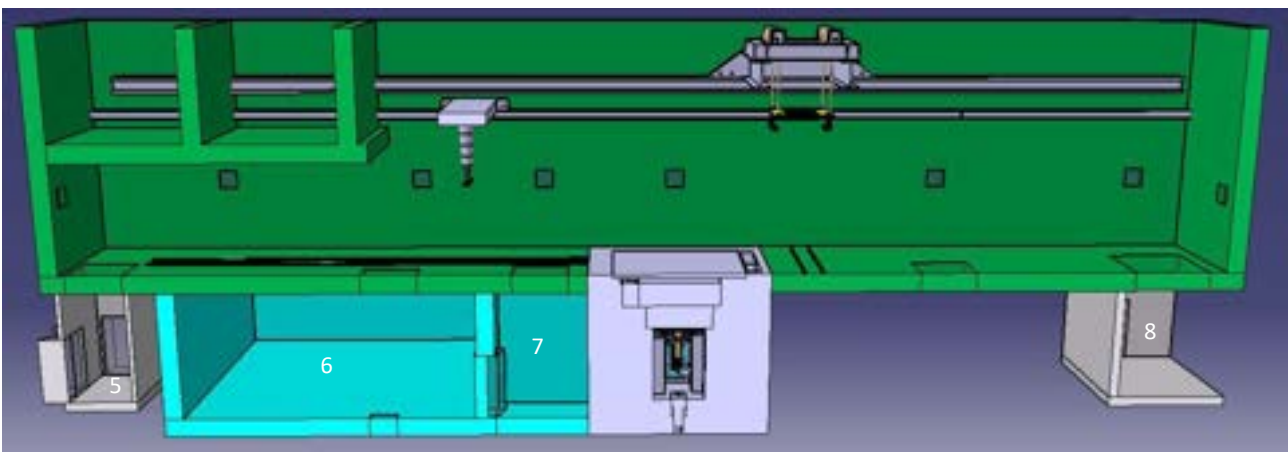

Fig. 8 Modifications of surrounding areas to the AC

In addition a new area has been included to host the High Level Control system (HLCS) for the RHS .

A 3D view of the final layout of the AC including the surrounding areas is shown in Fig. 9.

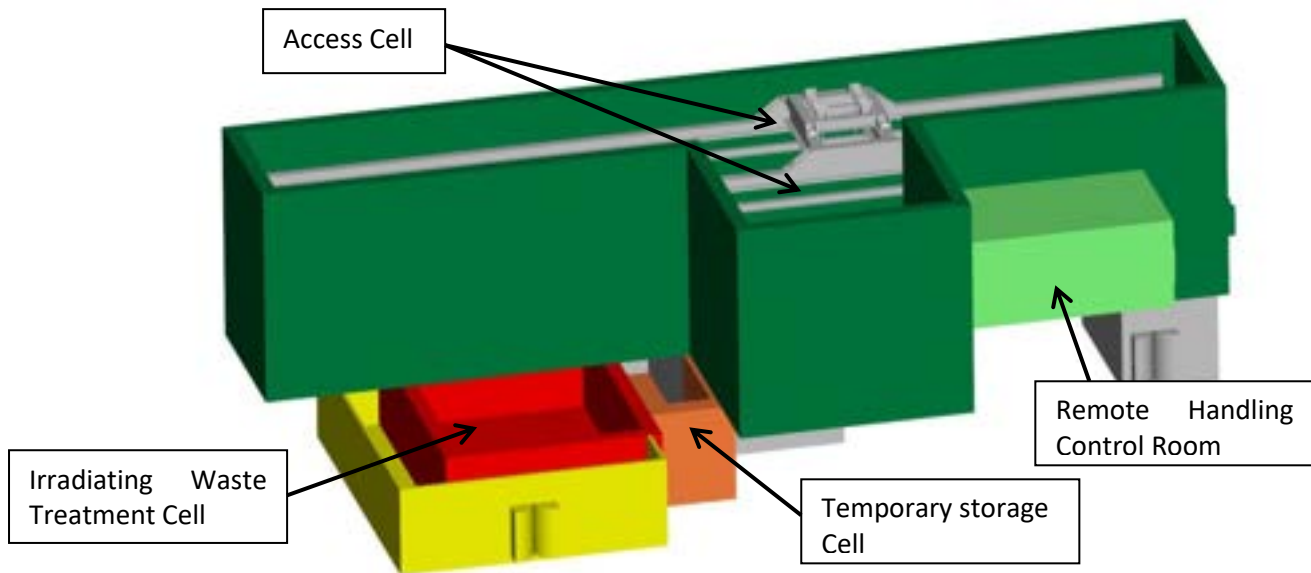

Fig. 9 3D view of AC and surrounding area.

3 Conclusions

A new lay out of the AC of IFMIF has been conceived. This new concept enables to perform almost all the maintenance operations to be performed for critical components belonging to the LF, the TF and the AF.

In details the following modifications have been proposed for the optimization of this area:

- 1) The new AC is based on a T shape. With this configuration it is now possible to perform the maintenance of components in the TIR and in the RIR
- 2) A maintenance and decontamination areas have been included in the AC for the maintenance of the cranes
- 3) A storage cell aimed at temporary store irradiated components coming from the TC has been resized
- 4) An IWTC aimed at store and at dismantling irradiated components has been rearranged
- 5) A separate area for the HLCS for the RHS of IFMIF has been included.

4 References

1. IIEDR-Plant_Design_Description_Document__23ECMR_v1_0 (2013)

5 ACRONIMS

AC	Access Cell
ACMC	Access Cell Mast Crane
AF	Accelerator Facility
EVEDA	Engineering Validation and Engineering Design Activities
HROC	Heavy Rope Overhead Crane
HFTM	High Flux Test Module
IFMIF	International Fusion Materials Irradiation Facility
ISP	Interface Shielding Plugs
IWTC	Irradiating Waste Treatment Cell
LF	Lithium Facility
LSP	Lower shielding plug
PCP	Piping and Cabling Plug
PKM	Parallel Kinematics Manipulator
QT	Quench Tank
RA	Robotic Arm
RAR	Robotic Arm on Rail
RH	Remote Handling
RHE	Remote Handling Equipment
RHS	Remote Handling System
RIR	Radiation Isolation Room
RM	Remote Maintenance
TA	Target Assembly
TBC	To Be Confirmed
TBD	To Be Defined
TC	Test Cell
TCCP	Test Cell Cover Plate
TIR	Target Interface Room
TF	Test Facility
TM	Test Module
TTC	Test and Target Cell
USP	Upper shielding plug