



Ricerca di Sistema elettrico

Caratterizzazione di edifici in clima mediterraneo ai fini della connessione ad una rete energetica

R. Fedrizzi, C. Dipasquale, M. Cozzini

EURAC
research

EUROPÄISCHE
AKADEMIE

ACCADEMIA
EUROPEA

EUROPEAN
ACADEMY

BOZEN - BOLZANO

Report RdS/PAR2015/153

CARATTERIZZAZIONE DI EDIFICI IN CLIMA MEDITERRANEO AI FINI DELLA CONNESSIONE AD UNA RETE ENERGETICA

ASSESSMENT OF BUILDINGS IN MEDITERRANEAN CLIMATE TOWARDS THEIR INTEGRATION IN DISTRICT HEATING AND COOLING NETWORKS

R. Fedrizzi, C. Dipasquale, M. Cozzini (EURAC)

Settembre 2016

Report Ricerca di Sistema Elettrico

Accordo di Programma Ministero dello Sviluppo Economico - ENEA
Piano Annuale di Realizzazione 2015

Area: Efficienza energetica e risparmio di energia negli usi finali elettrici e interazione con altri vettori energetici

Progetto: Tecnologie per costruire gli edifici del futuro

Obiettivo: B. Reti termiche distribuite

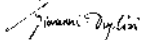
Responsabile del Progetto: Giovanni Puglisi, ENEA 

Il presente documento descrive le attività di ricerca svolte all'interno dell'Accordo di collaborazione per una attività di ricerca dal titolo: "Caratterizzazione di edifici in clima mediterraneo ai fini della connessione ad una rete energetica".

Responsabile scientifico ENEA: Giovanni Puglisi

Responsabile scientifico EURAC: Roberto Fedrizzi

1 Indice

1	INTRODUCTION.....	4
2	FEATURES OF THE BUILDING STOCK IN EUROPE WITH A FOCUS ON THE MEDITERRANEAN CLIMATE .	6
2.1	SIZE OF THE RESIDENTIAL STOCK	7
2.2	AGE OF THE RESIDENTIAL STOCK	8
2.3	BUILDING TYPE AND CONSTRUCTION	9
2.4	THERMAL PERFORMANCE AND U-VALUES	9
2.5	ENERGY CONSUMPTION AND DEMAND BY END USE	11
3	HEATING AND COOLING SYSTEMS SUITABLE FOR BUILDINGS IN THE MEDITERRANEAN CLIMATE.....	12
3.1	HEATING AND COOLING SYSTEMS DEFINITION	12
3.1.1	<i>Solar systems</i>	14
3.1.2	<i>Thermal storages</i>	16
3.1.3	<i>Buffer tank</i>	16
3.1.4	<i>Energy distribution systems</i>	17
4	PERFORMANCE FIGURES FOR SYSTEMS COMPARISON.....	17
4.1	PERFORMANCE INDICATORS FOR HEATING AND COOLING GENERATION UNITS.....	17
4.2	PERFORMANCE INDICATORS FOR HEATING AND COOLING (GENERATION AND DISTRIBUTION) SYSTEMS.....	18
4.3	PERFORMANCE INDICATORS FOR SOLAR THERMAL FIELD.....	22
4.4	PERFORMANCE INDICATORS FOR PHOTOVOLTAIC FIELD	22
4.5	PERFORMANCE INDICATORS FOR ECONOMIC ANALYSIS.....	23
5	ENERGY SOURCES AND SINKS FOR “NEUTRAL” DHC NETWORKS	25
5.1	WASTE HEAT FROM INDUSTRY	26
5.2	WIND AND SOLAR ENERGY	27
5.3	ENVIRONMENTAL HEAT SOURCES/SINKS	28
6	ROLE OF SHORT-TERM AND SEASONAL STORAGES IN “NEUTRAL” DHC NETWORKS	31
6.1	CATEGORIZATION OF HEAT STORAGES	31
6.2	STORAGE TANKS (TTES).....	32
6.3	PIT THERMAL ENERGY STORAGE (PTES)	34
6.4	BOREHOLE THERMAL ENERGY STORAGE (BTES)	36
7	CLASSIFICATION OF THE THERMAL NETWORK DISTRIBUTION CONFIGURATIONS	40
7.1	TWO PIPES IN COUNTERFLOW	41
7.2	TWO PIPES IN PARALLEL FLOW (WITH INVERSE RETURN)	41
7.3	ONE PIPE DISTRIBUTION	42
8	CONCLUSIONS.....	43
9	REFERENCES.....	44

1 Introduction

In Europe, the heating and cooling demand in the residential sector is responsible for a share of about 40% of the overall final energy usage [1]. However, the regulations introduced by the European Commission on the energy performance of new buildings in 2010 [2] and on the refurbishment of existing building stock in 2012 [3] could open new future scenarios. According to a study of the RHC Technology Platform (2011), a reduction is expected in the heating demand that will reach a value between -20% and -30% in 2050 compared with 2006. On the contrary, they maintain that the cooling demand could follow a remarkably different trend with a growth by a factor of 3 with respect to the current situation [1].

Researchers in this field acknowledge that district heating and cooling network (DHC) is a promising technology that could have an important role in the reduction both of primary energy consumptions and local pollution emission for space heating and cooling [4], [5]. Nevertheless, Connolly et al. (2013) claim that only 13% of the current heat market for the residential and service sector in Europe is covered by district heating [6], while the DHC+ Technology Platform (2012) reports that district cooling systems supply only a share of 2% of the overall cooling market [7]. The paradox is that district cooling systems are more widespread in the North than in the South of Europe. This is because “Southern countries have less experience with district energy systems and thus less courage to start a district cooling system” according to the results of the European project RESCUE [8]. These remarks are confirmed from the spatial distribution of the existent district heating and district cooling networks in Europe shown in Figure 1.

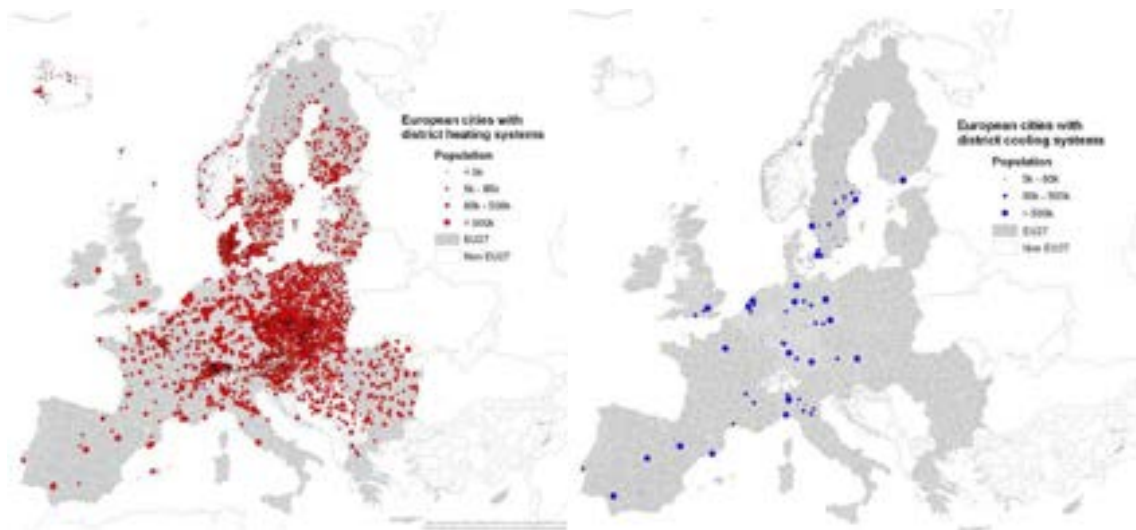

Figure 1: Maps showing European district heating and district cooling systems in 2011, respectively. Source: The European DHC database at Halmstad University (Urban Persson).

The standard way of thinking about district heating is that a centralised power station feeds hot water or steam into pipes that allow them to distribute thermal energy around a city. Unfortunately, current systems suffer from significant heat losses and high installation costs. These issues, together with the expected reduction in heating demand due to building stock refurbishment, could compromise the economic profitability of the existent infrastructures [9]. The absence of District Heating systems in areas of the southern Europe characterized by a Mediterranean climate could be due also on the shorter period of the winter season with respect to the northern countries. The lower heating demand entails a lower quantity of heat to sell and consequently a higher payback time of the investment, once fixed the same conditions for what concern e.g. the number of customers and the length of the network.

This fact has led to the adoption of individual heating and cooling systems like the ones shown in Figure 2: an air conditioner unit and a gas boiler to cover the space heating, space cooling and domestic hot water demands of the same building.



Figure 2: Typical individual heating and cooling systems in the southern Italy (Sven Werner) [10].

Therefore a technology that is able to provide both heating and cooling to different buildings simultaneously has a big potential in areas characterized by a Mediterranean climate. This is the challenge of “neutral” district heating and cooling networks called also “cold district heating” networks that are under investigation within the EU H2020 project “FLEXYNETS” [11]. This technology consists mainly in a network extended at a district level which is able to work at a temperature between about 10°C and 30°C. The main advantage of this solution is to minimize the thermal losses by working at a temperature level close to the ground. On the other hand, this advantage is paid with the need of invertible water source heat pumps which are already a mature technology. In this way it is possible to provide space heating, space cooling and domestic hot water at a suitable temperature to the final customers. The concept of such technology derives from Ground Source Heat Pump systems (GSHP) as well as Water Loop Heat Pump systems (WLHP). These latter are mainly widespread in the USA and Japan for commercial buildings where they are conveniently applicable when heating and cooling loads simultaneously occur [12]. In this way different loads could themselves balance the network for most part of the year.

Other strong points of this new technology are connected to the concept of sustainability: the very low temperature of the network allow recovering all waste heat available at higher temperature and also a better use of renewables (e.g. solar thermal). Moreover, this technology is able to be integrated with pre-existing DHC networks and also with the grids of different energy carriers. For instance, Fischer et al. (2014) emphasise how the utilization of electric driven heat pumps (EDHP) with appropriate control rules can be consider an opportunity for balancing fluctuations in the power grid due to renewable energy generation like wind and photovoltaic (PV) [13].

Until now, the utilization of electric driven low temperature heat pumps in small DHC networks is mainly related to individual big buildings or small residential neighbourhood where the application of Borehole Thermal Energy Storages (BTES) and Aquifer Thermal Energy Storages (ATES) is hydrogeological suitable or where deep lake water is available like in Geneva [14] and Toronto [15]. For instance, a low temperature DHC network launched at the end of 2014 in

Zürich provides heat and cool to about 400 households and a data centre through centralised heat pumps coupled to large borehole fields [16].

2 Features of the building stock in Europe with a focus on the Mediterranean climate

The total residential floor area in the EU-27 is approximately 17.6 billion m². Of this 15.1 billion m² is estimated to be heated. Almost three-quarters of this, 72%, lies in the ‘big six’ countries; Spain, Italy, France, Germany, UK and Poland.

The total heated floor area in each of the climate regions that have been defined to sub-divide the EU-27 countries is reported in Table 1. The age profile of the residential stock varies from country to country, but across all EU-27 countries the age of both single family houses (SFHs) and multi-family houses (MFHs) is broadly similar. The rate of new build has been slowing since the 1970s, with the most dramatic reduction occurring since 2000.

However, the residential mix between SFHs and MFHs differs widely between the EU-27 countries. Denmark, Ireland, Netherlands and United Kingdom have the highest proportions of SFHs (all above 70%) whereas Estonia, Italy, Latvia and Spain have the lowest proportions of SFHs (all below 40%).

Table 1 – Climatic regions, countries and associated residential heated and cooled floor area m²

Region	Countries (big six in bold)	Total floor area Mm ²	Heated floor area Mm ²	Cooled floor area Mm ²
Southern Dry	Portugal, Spain	1978	1504	965
Mediterranean	Cyprus, Greece, Italy Malta	2952	1980	423
Southern Continental	Bulgaria, France , Slovenia	2738	1871	178
Oceanic	Belgium, Ireland, United Kingdom	2488	2387	12
Continental	Austria, Czech Republic, Germany , Hungary, Luxembourg, Netherlands	4831	4783	74
Northern Continental	Denmark, Lithuania, Poland , Romania, Slovakia	1933	1914	14
Nordic	Estonia, Finland, Latvia, Sweden	685	678	3

The yearly residential heating energy consumption across the EU-27 is 2299TWh (see Table 2), which gives an average energy consumption of 152 kWh/(m²y) (heated area taken as a reference). Around this average figure, yearly energy use in separate EU-27 countries varies from 19kWh/(m²y) in Malta to 215kWh/(m²y) in Latvia (excluding Luxembourg).

The residential cooling energy consumption across the EU-27 is 26TWh/year. Due to the size and climate Spain has the greatest total cooling consumption at 13TWh/year.

At EU-27 level, DHW consumption in residential buildings is approximately 20% of the space heating, at 459TWh/year. Total energy consumption for hot water is much more closely linked to the size of each country’s population, with Germany accounting for the largest proportion at 91 TWh/year.

Total EU-27 lighting consumption is approximately 97 TWh/year, averaging at about 5kWh/m²/year.

Table 2 – Residential specific and total energy demand and consumption by end-use

End-use	Specific demand kWh/(m ² y)	Specific consumption kWh/(m ² y)	Total demand TWh/y	Total consumption TWh/y
Heating	144	152	1898	2299
Cooling	50	16	-	26
DHW	21	26	-	459
Lighting	5	5	97	97

2.1 Size of the residential stock

The residential floor area for each country is summarised in Table 3. As this report is primarily in support of energy-saving retrofit measures, then heated space is separately listed. Heated floor area is also allocated to either single-family houses (SFH) or multi-family houses (MFH), to show the split between these kinds of dwelling.

The total residential floor area in the EU-27 is approximately 17.6 billion m². Of this 15.1 billion m² is estimated to be heated. The majority of the residential floor area in Europe, 72%, lies in the ‘big six’ countries; Spain, Italy, France, Germany, UK and Poland. This of course reflects the size of the population in these respective countries. A map showing total residential floor area by country is shown in Figure 3.

Table 3 – Summary of floor areas per country (million m²)

Regions	Countries	Total res	Heated res	Cooled res	Heated SFH	Heated MFH
Southern Dry	Portugal	410.1	240.3	24.6	134.6	105.7
	Spain	1568.0	1263.4	940.8	416.9	846.5
			1503.7	965		
Mediterranean	Cyprus	38.9	23.3	29.2	14.9	8.4
	Greece	322.6	310.6	274.2	160.3	150.3
	Italy	2576.9	1638.4	109.2	491.5	1146.8
	Malta	13.5	8.1	10.1	6.3	1.8
			1980.4	423		
Southern Continental	Bulgaria	197.2	195.3	43.4	107.4	87.9
	France	2479.5	1615.8	124.0	1098.7	517.0
	Slovenia	67.3	55.0	10.3	42.4	12.7
			1866.0	178		

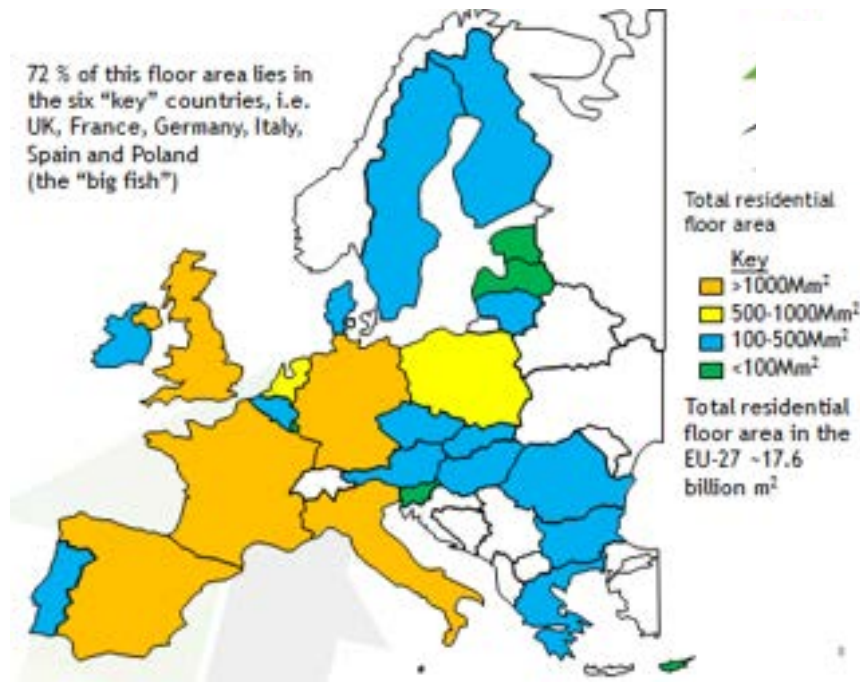

Figure 3 - Map of total residential floor area by country

Table 4 – Country breakdown of SFH and MFH construction by age band (Mm2)

Regions	Countries	Up to 1970 (SFH)	Up to 1970 (MFH)	Up to 1970 Total	1971-80 (SFH)	1971-80 (MFH)	1971-80 Total	1981-90 (SFH)	1981-90 (MFH)	1981-90 Total	1991-2000 (SFH)	1991-2000 (MFH)	1991-2000 Total	After 2000 (SFH)	After 2000 (MFH)	After 2000 Total
Southern Dry	Portugal	38	22	60	24	23	47	26	20	46	27	26	53	20	14	34
	Spain	145	295	440	88	179	267	54	110	164	67	135	202	63	127	190
Mediterranean	Cyprus	2.7	1.2	3.9	2.1	1.3	3.4	2.5	1.7	4.2	2.7	1.4	4.1	4.9	2.9	7.8
	Greece	63	59	121	40	38	78	29	27	56	19	18	37	10	9	19
	Italy	305	711	1016	87	203	290	57	132	188	29	69	98	15	34	49
	Malta	2.5	0.4	3.0	1.4	0.4	1.8	1.7	0.5	2.2	0.7	0.3	1.0	0.0	0.2	0.2
Southern Continental	Bulgaria	71	47	117	16	18	34	13	12	25	6	6	13	1	5	6
	France	582	326	908	143	67	210	132	41	173	143	47	189	99	36	135
	Slovenia	19.5	5.8	25.3	9.7	2.9	12.7	7.2	2.2	9.4	3.0	0.9	3.9	3.0	0.9	3.9

2.2 Age of the residential stock

The majority of the residential stock within the EU-27 countries dates from before 1971. This reflects the developed nature of the EU economies and also the post-war reconstruction of the 1950s and 1960s. The EU-wide percentages of floor area constructed in SFHs and MFHs are shown country-by-country breakdown is shown in Table 4.

After 1945 there was an urgent need to rebuild quickly and cost effectively and this resulted in construction of energy inefficient homes. Standardised building methods were introduced in the 1950s. Industrially prefabricated constructions and composite construction methods were used during the 1950s and 1960s to reduce construction costs.

Table 4 shows the breakdown of SFH and MFH construction by age.

2.3 Building type and construction

To simplify the analysis of the residential stock across the EU-27 countries, two residential building types have been defined:

- SFH (single family house) - a single dwelling unit within its own building, for example a detached, semi-detached or terrace house.
- MFH (multi-family house) - a dwelling in a multi-occupancy building, for example a flat within a house that has been converted into separate flats, or a flat within a purpose-built apartment block.

Across the EU-27 60% of residential floor space consists of single family houses and the remaining 40% is multi-family houses. Figure 4 shows a map detailing the percentage of single family houses by country based on floor area.

In the Mediterranean countries like Italy and Spain, the large majority of buildings are MFHs: Italy 70% and Spain 67%. In the other Mediterranean countries a more balanced share of SFHs and MFHs is assessed.

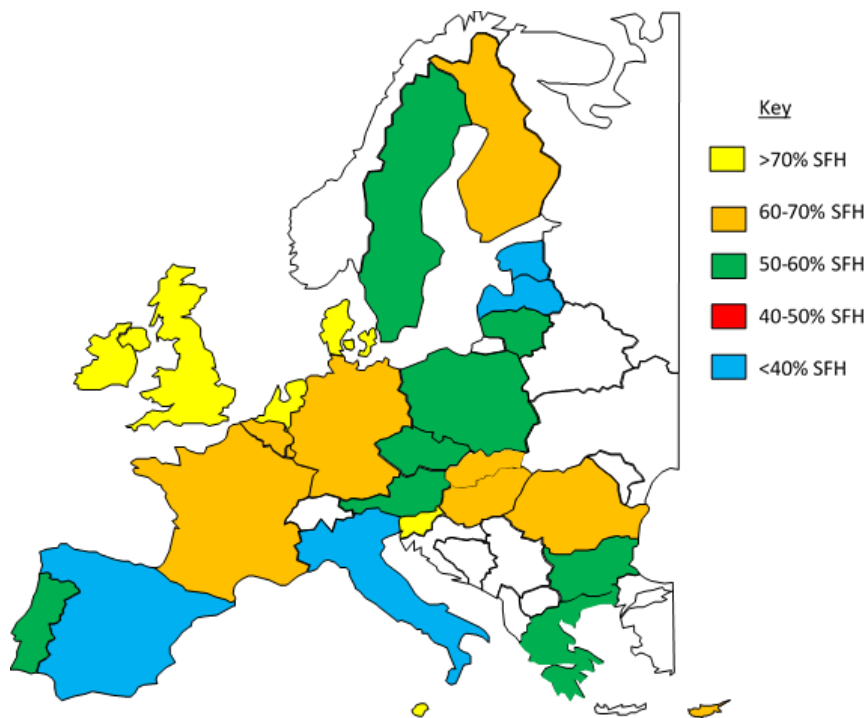

Figure 4 - Percentage of SFHs in each EU-27 country

2.4 Thermal performance and u-values

Table 5 and Table 6 show a summary of residential u-values for all countries, separated into the standard age bands. The countries are grouped into their climate regions.

Thermal performance across all EU-27 countries has generally improved since 1945, as would be expected. In many cases the improvement has been dramatic, such as in Austria, Denmark, France, Germany, Netherlands, Slovenia and UK with roof, wall and floor u-values in these countries reducing from greater than 1.0 down to 0.3 in many cases. In some countries, u-values have improved a lot recently, as a result of much more stringent regulations driven in part by EU-wide commitments to improve energy efficiency and reduce carbon emissions.

Table 5 - Summary of residential u-values by country and climate region. Walls and windows.
Weighted averages over total floor area. Source: BPIE, ENTRANZE, ODYSSEE

Climatic region	Total floor space in EU (Mm2)	Country	RESIDENTIAL WEIGHTED AVERAGES - WALL							RESIDENTIAL WEIGHTED AVERAGES - WINDOW							
			uvalues W/m ² /K							uvalues W/m ² /K							Calcu
			Pre 1945	1945-1970	1970-1980	1980-1990	1990-2000	Post 2000	Average	Pre 1945	1945-1970	1970-1980	1980-1990	1990-2000	Post 2000	Average	
Southern dry																	
	410	Portugal	2.0	1.5	1.5	1.4	1.2	0.8	1.4	4.3	4.2	4.2	4.2	4.2	3.2	4.0	
	1,568	Spain	2.5	2.1	2.1	1.6	1.6	0.8	1.8	5.7	5.7	5.7	3.3	3.3	3.1	4.5	
		WEIGHTED avg	2.4	2.0	2.0	1.6	1.5	0.8	1.7	5.4	5.4	5.4	3.3	3.3	3.1	4.4	
Mediterranean																	
	39	Cyprus	2.1		1.4	1.4	1.4	1.4	1.5	5.8		5.8	5.8		2.7	5.0	
	323	Greece	1.6	1.6	1.6	0.9	0.9	0.7	1.2	4.1	4.1	4.1	3.2	3.2	3.1	3.6	
	2,577	Italy	1.8	1.6	1.6	1.0	0.9	0.9	1.3	5.4	5.4	4.6	4.1	4.0	4.0	4.6	
	14	Malta	2.0	2.0	1.5	1.5	1.5	1.5	1.6	5.8	5.8	5.8	5.8	5.8	5.8	5.8	
		WEIGHTED avg	1.8	1.6	1.6	1.0	0.9	0.8	1.3	5.3	5.2	4.5	4.0	3.9	3.9	4.5	
Southern Continental																	
	197	Bulgaria	1.6	1.6	1.5	1.2	1.0	0.5	1.2	2.7	2.7	2.7	2.7	1.8		2.5	
	2,480	France	2.4	2.4	1.0	0.7	0.5	0.4	1.2	4.2	4.2	3.6	3.0	2.1	1.8	3.1	
	61	Slovenia	1.5	1.5	1.4	0.8	0.6	0.2	1.0	2.4	2.3	2.1	1.9	1.7	1.5	2.0	
		WEIGHTED avg	2.4	2.3	1.1	0.8	0.5	0.4	1.2	4.0	4.0	3.5	2.9	2.0	1.8	3.1	
Oceanic																	

Table 6 - Summary of residential u-values by country and climate region. Floors and Roofs.
Weighted averages over total floor area. Source: BPIE, ENTRANZE, ODYSSEE

Climatic region	Total floor space in EU (Mm2)	Country	RESIDENTIAL WEIGHTED AVERAGES - FLOOR							RESIDENTIAL WEIGHTED AVERAGES - ROOF							
			uvalues W/m ² /K							uvalues W/m ² /K							Calcu
			Pre 1945	1945-1970	1970-1980	1980-1990	1990-2000	Post 2000	Average	Pre 1945	1945-1970	1970-1980	1980-1990	1990-2000	Post 2000	Average	
Southern dry																	
	410	Portugal	2.1	2.1	2.1	2.1	2.0	1.3	1.9	3.1	3.0	2.7	2.6	2.4	1.3	2.5	
	1,568	Spain	2.5	2.5	2.5	0.8	0.8	0.7	1.6	1.8	1.4	1.4	1.0	1.0	0.5	1.2	
		WEIGHTED avg	2.4	2.4	2.4	1.1	1.0	0.8	1.7	2.0	1.7	1.6	1.3	1.3	0.7	1.4	
Mediterranean																	
	39	Cyprus										3.3	3.3	0.6	0.6	1.9	
	323	Greece	2.4	2.4	2.4	2.4	2.3	0.7	2.1	2.5	2.5	2.5	1.1	1.1	0.5	1.7	
	2,577	Italy	1.9	1.8	1.6	1.4	1.4	1.3	1.6	2.2	2.0	1.7	1.2	1.0	0.9	1.5	
	14	Malta	3.0	3.0	3.0	2.0	2.0	2.0	2.5	1.9	1.9	1.9	1.9	1.8	1.8	1.9	
		WEIGHTED avg	1.9	1.9	1.7	1.5	1.5	1.2	1.6	2.2	2.1	1.8	1.2	1.0	0.9	1.5	
Southern Continental																	
	197	Bulgaria	1.0	1.0	1.0	0.6	0.5	0.5	0.8	1.3	1.3	1.2	1.1	0.5	0.3	0.9	
	2,480	France	1.9	1.9	0.8	0.7	0.5	0.4	1.0	2.5	2.4	1.1	0.7	0.6	0.2	1.3	
	61	Slovenia	1.3	1.2	0.9	0.8	0.6	0.2	0.8	1.3	1.2	1.0	0.7	0.4	0.2	0.8	
		WEIGHTED avg	1.9	1.8	0.9	0.7	0.5	0.4	1.0	2.4	2.3	1.1	0.8	0.6	0.2	1.2	
Oceanic																	

Countries with warm climates, such as Spain, Greece, Malta, Cyprus have improved but to a much less extent. As these are countries where air conditioning in dwellings is more widespread, then an improvement in thermal performance would still be valuable as it would reduce the need for summertime cooling.

It is recognised that a proportion of the older residential (and office) stock has had some sort of upgrades. This may range from boiler replacement, some sort of insulation improvements (such as loft insulation and cavity wall insulation) or window replacements. The literature review did not find sufficient data to categorise the amount of the EU-27 stock that has been upgraded therefore no corrections have been applied to the u-values and energy given in the database to take account of this. Therefore the u-values given in the tables relate to those at time of construction.

2.5 Energy consumption and demand by end use

Table 7 reports on the heating and cooling demands and consumptions for the countries characterised by a Mediterranean climate.

There are statistical uncertainties due to the lack of data for some countries. The heated and cooled areas, in a few cases, had to be estimated which therefore creates some uncertainties over the averages and total figures reported.

The Southern Dry region has lowest specific heating consumption and Southern Continental has the highest (at 180 kWh/m²/year) due to the weighting from France, which covers many climates.

Table 7 - Average demand and consumption for space heating and cooling in residential buildings.

	Countries	Total floor area (Mm ²)	Heated floor area (Mm ²)	Cooled floor area (Mm ²)	Specific heat demand (kWh/m ² ·y)	Specific heat consumption (kWh/m ² ·y)	Demand / Consumption	Specific cold demand (kWh/m ² ·y)	Specific cold consumption (kWh/m ² ·y)	Demand / Consumption
Southern Dry	Portugal	410	240	25	111	128	87%	37	14	2.6
	Spain	1568	1263	941	124	80	155%	54	14	3.9
Average/Total		1978	1504	965	122	87	140%	54	14	3.9
Mediterranean	Cyprus	39	23	29	82	55	149%	53	12	4.4
	Greece	323	31	274	91	129	71%	51	27	1.9
	Italy	2577	1638	109	142	138	103%	47	14	3.4
	Malta	13	8	10	21	19	111%	53	23	2.3
Average/Total		2952	1980	423	132	135	98%	50	22	2.3
Southern Continental	Bulgaria	197	195	43	56	91	62%	46	7	6.6
	France	2479	1616	124	132	193	68%	35	18	1.9
	Slovenia	61	60	10		142	0%	47	10	4.7
Average/Total		2738	1871	178	123	180	68%	38	15	2.5

With regards to average energy consumption for domestic hot water consumption, Bulgaria has the lowest at 8 kWh/m²/year and although this was reported in a number of sources, seems rather low when compared to other countries.

Spain has the greatest specific cooling energy consumption at 54 kWh/m²/year, followed by Cyprus and Malta at 53 kWh/m²/year.

When comparing the average heating demand and consumption with the exception of Southern Dry and Continental, regional specific demand figure is greater suggesting boiler efficiency ranging between 68% and 98%.

3 Heating and cooling systems suitable for buildings in the Mediterranean climate

The heating demand values reported in the previous chapter show that the large majority of the buildings actually existing in the Mediterranean countries can only be properly warmed with high temperature generation and distribution systems, e.g. gas boilers and radiators.

At the same time, cooling demand is relatively high, since generally shading strategies only include closing the shutters during highest temperatures days of the year.

This kind of building cannot be connected effectively to a network that can deliver both heating and cooling as it has been proven in a small number of demonstration cases. This is because, sorption chillers installed in single buildings and driven by the thermal network suffer of high capital and maintenance costs.

On the contrary, the utilisation of invertible-cycle compression heat pumps feature low capital and maintenance costs, however with a limitation on the warm-cold fluid delivery and, with respect to on-the-shelf split units, with relatively high electricity consumption levels.

This kind of systems can be also connected to a low temperature (10 to 25 °C) heating and cooling network in order to increase the performance of the heat pump both in heating and cooling operation.

The definition of effective heating and cooling systems is not an easy task. However it seems to be a reasonable assumption to consider the utilisation of invertible-cycle compression heat pump systems with regards to newly built and retrofitted buildings, and the use of combinations of heat pump + gas boiler for systems driving elderly built constructions.

In the rest of this chapter, we identify possible heating and cooling systems with reference to the most energy efficient cases.

3.1 Heating and cooling systems definition

A reference H&C configuration structure has been defined, from which other H&C configuration variants can easily be derived, composed of a generation system, a distribution system, a storage for DHW, a buffer storage for heating and cooling distribution and solar thermal and photovoltaic systems.

Three generation units have been considered: air to water heat pumps (AWHP), water to water source heat pumps (WWHP) and gas boilers (GAS, see Figure 5).

The solar thermal field supplies renewable energy into a thermal storage tank in parallel with the main generation unit; depending on the size of the field, the solar energy is used only for DHW preparation (smaller fields compared to the load) or for both heating and DHW preparation (larger fields).

The PV field is used for both driving the generation/distribution systems – namely generation units, pumps, valves and backup heater – and covering the building's electric appliances. In order to compare the effectiveness of the solar thermal solutions with the PV ones, the PV electricity used to drive the H&C system is treated separately from the one used for the appliances. The excess PV electricity is considered fed into the grid.

With respect to the distribution system, we considered the possible use of radiant ceilings, fan coils and radiators. In the latter case, a split unit is foreseen in addition to the mentioned generation units as the unique source of cooling.

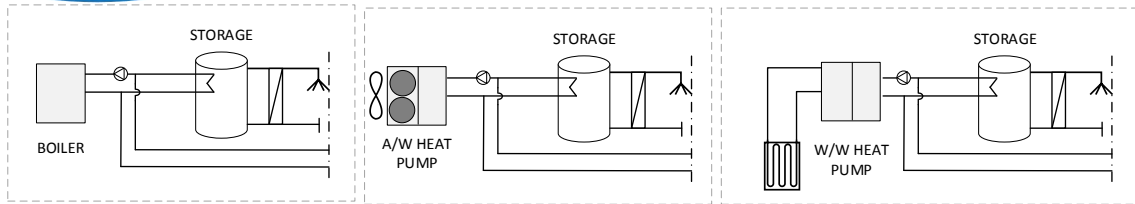

Figure 5 – Generation unit solutions

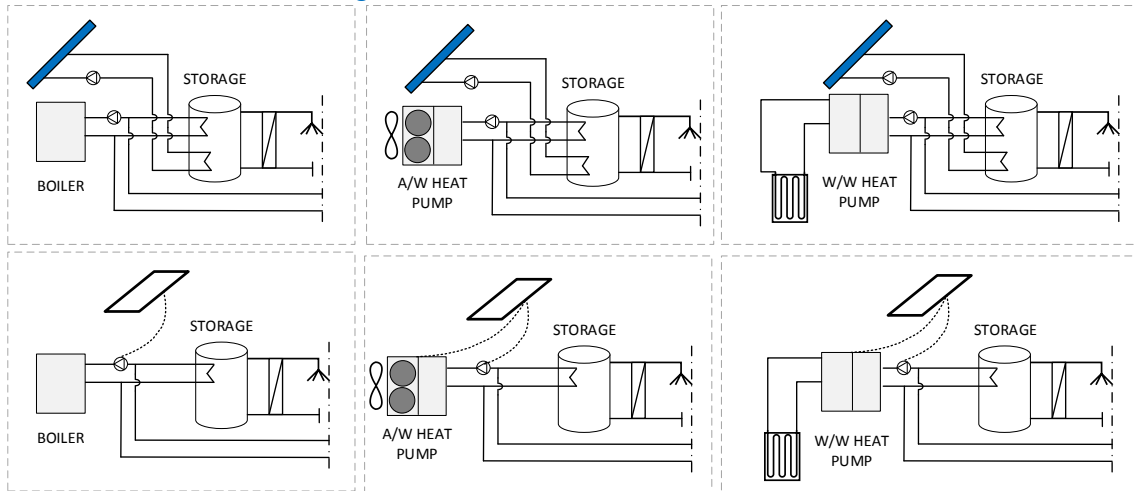

Figure 6 – Generation renovation packages with solar thermal field (above) and PV panels (below)

Figure 7 shows the configuration of the reference H&C system considered. The PV field is not represented for the sake of simplicity; again to better clarify the concept, the DHW thermal storage is represented here separately from the solar thermal storage: in single family homes, the two are integrated into one single volume, the solar storage being located at the bottom part of the combi-storage.

In multifamily buildings, it is usually hard finding the needed space for a large combi-storage; therefore, it is often necessary to separate different functionalities in multiple storages.

In any case, the solar storage can be considered as placed in series to the DHW tank and the solar thermal field. In the solutions where no solar thermal field is considered, the solar thermal storage volume is set to zero.

The generation unit delivers heat and cold to the distribution system, through a small buffer tank: in case of heat pumps, this limits the number of on-off cycles and in winter it can be used for AWHP de-icing by reversing the cycle. The size of the buffer tank strongly depends on the generation technology.

“Solar heating” can be provided to the building by drawing warm water from the solar storage tank when a specific set temperature is exceeded.

A pump + mixing valve unit delivers heat and cold to each thermal zone (floor or dwelling depending on the building) with the needed set temperature and mass flow.

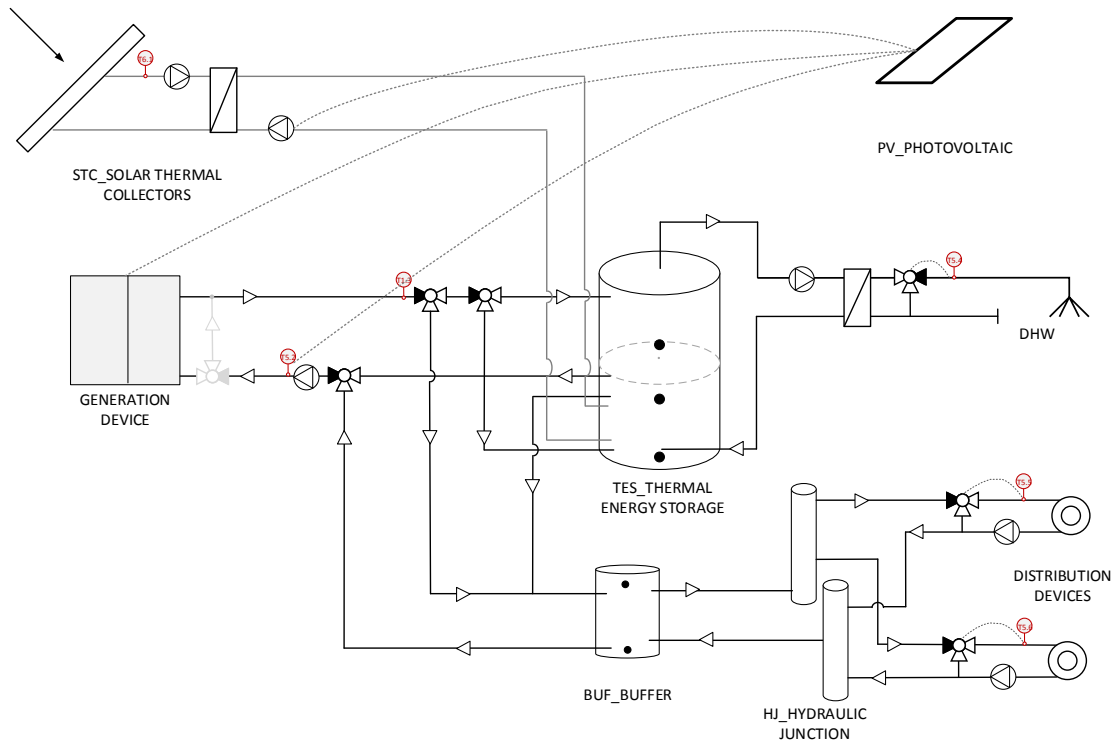

Figure 7 – Reference H&C system used to simulated different Generation and Distribution Renovation Packages

AIR TO WATER HEAT PUMP: the thermal capacity of an AWP is strongly dependent on the load's and source's temperatures. This said, this component has been sized to cover the maximum heating load with an outside air temperature of $-5\text{ }^{\circ}\text{C}$. Below this, a back-up electric heater is switched on.

Since data are provided at standard rating conditions, a correction factor (1.65) for the size is used to increase both rated thermal capacity and electric consumption to nominal design conditions, being sure that performance at $-5\text{ }^{\circ}\text{C}$ are still sufficient to cover the maximum thermal load.

GROUND SOURCE HEAT PUMP: instead of connecting a water to water heat pump to a geothermal heat exchanger, this kind of a unit can be connected to a heating and cooling network. In this way, it can profit of source temperatures allowing for very high COP and EER values on the one hand. On the other, the size of the heat pump can be reduced to the minimum required by the loads, since the source temperature is maintained within a narrow range of temperatures around the rated condition.

GAS BOILERS AND SPLIT UNITS: only the case of condensing boilers is taken into consideration. As already highlighted, in southern countries, a typical and inexpensive heating and cooling solutions is based on the combination of gas boiler and split unit. Although this combination is not suitable for the integration into heating and cooling networks, it has to be considered as a reference case which the innovative solutions are compared to.

3.1.1 Solar systems

For the installation of the solar thermal and photovoltaic systems, two main variants are considered, as illustrated in the Figure 8:

- On the best-oriented roof
- On the best-oriented façade

With respect to residential buildings, because of the windows and chimneys, the surfaces cannot be completely covered with photovoltaic (PV) modules / solar thermal (ST) collectors. We assume therefore that only 60% of the façade and 80% of the roof surface can be covered.

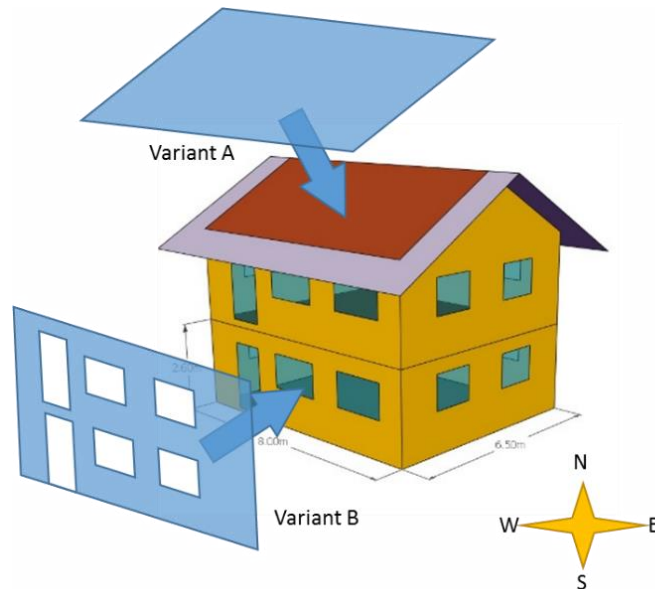

Figure 8 – The two solar systems orientation variants

PHOTOVOLTAIC MODULES: the manufacturing data of an average mono-crystalline PV module have been considered for the parameterization and sizing of the PV panels, with an active area of 1.31 m^2 per panel. Beside the inclination variants, different number of PV panels can be considered:

SFH

- 1 series of 6 panels (total active area: 7.8 m^2 - around 1 kWp)
- 2 series of 6 panels (total active area: 15.6 m^2 - around 2 kWp)
- 3 series of 6 panels (total active area: 23.4 m^2 - around 3 kWp)

MFH – 5 floors

- 3 series of 6 panels (total active area: 23.6 m^2 - around 3 kWp)
- 4 series of 6 panels (total active area: 31.4 m^2 - around 4 kWp)
- 5 series of 6 panels (total active area: 39.6 m^2 - around 5 kWp)

SOLAR THERMAL COLLECTORS: the manufacturing data of an average solar thermal collector ($\eta_{a0} = 0.82$, $a_1 = 3.8$) with an active area of 2.3 m^2 have been considered for the parameterization and sizing of the solar thermal field. Beside the inclination variants, different number and configuration of solar thermal collectors can be considered:

SFH

- 1 series of 2 collectors (total active area: 4.6 m² - only DHW preparation)
- 1 series of 4 collectors (total active area: 9.2 m² - DHW preparation and space heating)
- 2 series of 3 collectors (total active area: 13.8 m² - DHW preparation and space heating)

MFH

- 2 series of 4 collectors (total active area: 18.4 m² - only DHW preparation)
- 3 series of 4 collectors (total active area: 27.6 m² - DHW preparation and space heating)
- 4 series of 4 collectors (total active area: 36.8 m² - DHW preparation and space heating)

3.1.2 Thermal storages

The sizing of the thermal energy storage is based on both the requirements related to the DHW load and to the volume needed to store solar thermal energy. In case solar thermal collectors are not installed, a minimum storage volume is considered. In case solar thermal collectors are actually installed, the maximum volume is selected among the DHW and the solar thermal tank size, the latter being defined as:

- 50 l/m² (litres of the storage tank per surface of the collectors' area)
- 100 l/m²

We selected this range based on the usual practice for solar thermal systems.

3.1.3 Buffer tank

For the air source heat pump, the buffer tank is sized to guarantee the minimum energy required for a de-icing cycle by inverting the compression cycle. This phase is required to avoid the HP performance decreasing due to ice formations on the surface of the evaporator. The buffer tank is sized in order to store the required energy from the HP for the de-icing procedure. The sizing is based on this balance:

$$E_{HP_{DI}} = E_{Buffer}$$

Where the left term is the energy required by the evaporator of the HP at nominal conditions for the de-icing, while the right term is the energy that the buffer can store,

$$E_{HP_{DI}} = P_{HP_{ev}} * time_{DI}$$

The right term can be written also as the evaporator power ($P_{HP_{ev}}$) for the de-icing duration: a $time_{DI} = 30'$ has been considered in this study, as this is a timeframe not affecting the indoor comfort (the heat pump does not deliver heating to the building during de-icing), therefore many units adopting cycle inversion for de-icing purposes operate in this way. Consequently, the buffer energy stored during the de-icing is:

$$E_{Buffer} = V_{buffer} * \rho_{water} * c_{p_{water}} * (t_{max} - t_{min})$$

Where t_{max} is the set point temperature held in the buffer, supplying the distribution system, and $t_{min} = 15^{\circ}\text{C}$, is the minimum temperature acceptable in the buffer. The buffer tank volume so designed is also useful to reduce the on-off cycles of the heat pump which thermal capacity is most of the times oversized compared to the space heating and cooling thermal loads. Thus, the buffer tank is used also for systems with ground source heat pump.

3.1.4 Energy distribution systems

For the parameterisation and sizing of the different energy distribution systems, manufacturing data and self-made measurements have been considered for a range of units:

RADIANT CEILINGS: a nominal capacity for radiant ceilings of around 140 W/m^2 in heating mode and about 100 W/m^2 in cooling mode (both at $\Delta\theta$ of 10°C) has been considered. With an inlet temperature in the panel of 35°C and a flow rate per panel of 50 kg/hr , the radiant panel capacity is around 140 W/m^2 , while with a temperature of 30°C the capacity decrease to 93 W/m^2 . In the cooling conditions the panel capacity is around 87 W/m^2 because of a smaller ($\Delta\theta$) between the average panel temperature and the ambient. Radiant panels do not dehumidify the air.

FAN COILS: the manufacturing data of the vertical 2-tubes fan coil has been considered for the sizing and parameterization of the fan coils model. Based on manufacturer data, the performance of fan coils has been evaluated as a function of the inlet mass flow rate (water side) and the temperature difference between the inlet water and air.

RADIATORS: The water mass flow rate is decided based on the model's performance at specific inlet water temperatures (35 or 45°C in the cases considered for installation with heat pump systems), in order to install a temperature difference between inlet and outlet of 5°C .

4 Performance figures for systems comparison

As part of the future work, three systems will be compared in order to assess and compare their performance from the energy and economic point of view:

1. A water-to-water heat pump based system with the described architecture and connected to a low-temperature DHC network
2. An air-to-water heat pump based system with the described architecture
3. A conventional system using a condensing boiler and split units.

Additionally to this, combinations of the heat pump systems with gas boilers will be talked, in order to evaluate the operation with regards to buildings with low energy performance, which cannot be fully served by means of low-enthalpy solutions.

In this chapter we define the performance figures that allow assessing the systems' operation.

4.1 Performance indicators for heating and cooling generation units

The performance of the H&C generation units are reported in terms of:

SCOP: The COP is defined as the ratio of the heat output of the heat pump unit to the effective electricity input to the unit for a stationary operating condition. In this case, the ratio is calculated based on the average seasonal values both thermal and electric.

$$SCOP_{DHW} = Q_{DHW} / E_{DHW}$$

$$SCOP_{SH} = Q_{SH} / E_{SH}$$

$$SCOP_{tot} = (Q_{DHW} + Q_{SH}) / (E_{DHW} + E_{SH})$$

SEER: The EER is defined as the ratio of the cold output of the reversible heat pump unit to the effective electricity input to the unit for a stationary operating condition. In this case, the ratio is calculated based on the average seasonal values both thermal and electric.

$$SEER_{SC} = Q_{SC} / E_{SC}$$

THERMAL EFFICIENCY: in case boilers are considered, the thermal efficiency is the ratio of the heat output to the building to the energy entailed in the fuel consumed, expressed by the Higher Calorific Value (HCV).

$$\eta_{DHW} = Q_{DHW} / HCV_{DHW}$$

$$\eta_{SH} = Q_{SH} / HCV_{SH}$$

$$\eta_{tot} = (Q_{DHW} + Q_{SH}) / (HCV_{DHW} + HCV_{SH})$$

For non-condensing boilers, like biomass ones, this value ranges between 0.8 and 0.85. For condensing boilers this value ranges between 0.9 and 0.95, while for gas driven sorption heat pumps values up to 1.2 can be reached.

The boundaries for the assessment of the above energy fluxes are set just around the unit, meaning that we consider the electricity needed to run the HP compressor, backup electric heater and fan (the latter in case of AWHP), while the electricity used to drive any pumps is not accounted for.

4.2 Performance indicators for heating and cooling (generation and distribution) systems

The above performance figures can be used also when moving the study from the single unit to the entire generation and distribution system.

In this case, the electricity consumption figures also account for the energy used by all the pumps, valves and control unit (a constant 20 W consumption 24/7 is accounted for, in order to consider this contribution), as well as the electricity used by the mechanical ventilation (0.4 Wh/m³ of fresh air exchanged).

In this case, SCOP and SEER are referred to as **SPF: SEASONAL PERFORMANCE FACTOR**.

In addition to the SPF and thermal efficiencies, the database reports also on systems':

FINAL ENERGY USE: for electricity driven systems, the FE equals the electricity used to drive the HVAC systems, while for gas or biomass driven ones, the FE equals the HCV of the used fuel by its mass consumption.

PRIMARY ENERGY USE: In order to compare systems and technologies in terms of their environmental impact, the use of the Primary energy concept is recommended in this report. The PE use gives information on the consumption of non-renewable energy sources for the provision of useful energy output of the system. Note that this does not account for the production, distribution, installation and end-of-life disposal of the HVAC system itself. It is a figure which considers the depletion of limited energy resources contained in e.g. fossil fuels. For the calculation of this figure, the CED_{NRE} – Cumulative Energy Demand (CED), non-renewable – is used: it quantifies the non-renewable primary energy used to provide the final energy, including the energy used for construction of the electric grid and power plants. This indicator accounts for the primary energy from fossil, nuclear and primary forest resources (i.e. original forests that are destroyed and replaced by farmland) defined in terms of primary energy to final energy - kWh_{PE}/kWh_{FE} .

$$PE = FE * CED_{NRE}$$

Since the provenance of the electrical energy at the plug varies widely from country to country due to their power generation and import mixes, it is important to define reference values for comparison purposes. For the electric energy, the corresponding European electricity supply mix (ENTSO-E – European Network of Transmission System Operators for Electricity) on low voltage level for these two indicators was chosen (Task 44, Deliverable B1).

The primary energy factor is for non-renewable energy and the value used is a European average for the year 2012. As such it is larger than the relevant values for certain individual countries and it will decrease with time as a consequence of the expected increasing RES penetration in the electricity market.

For all other energy carriers, the values for each country are nearly identical and are taken from the Ecoinvent database (Ecoinvent (2013)) that contains a large number of processes for production of goods and provision of services with a focus on European production chains (see Table 8).

PRIMARY ENERGY RATIO: the same calculation approach used for the SPF definition can be used for the calculation of the PER. In this case, the PE is used instead of the FE at the denominator. This allows to compute a performance figure that comprehends all the different energy uses that cannot be summed up as is.

$$PER_{DHW} = Q_{DHW} / PE_{DHW}$$

$$PER_{SH} = Q_{SH} / PE_{SH}$$

$$PER_{SC} = Q_{SC} / PE_{SC}$$

$$PER_{tot} = (Q_{DHW} + Q_{SH} + Q_{SC}) / (PE_{DHW} + PE_{SH} + PE_{SC})$$

Table 8 - CED_{NRE} for different energy carriers (Malenkovic I., 2012)

Energy carrier	CED _{NRE} [kWh _{FE} /kWh _{FE}]
Electricity	2.878
Gas	1.194
Oil	1.271
Wood	
logs	0.030
pellets	0.187
chips	0.035

SOLAR FRACTION, AEROTHERMAL/GEOTHERMAL FRACTION AND RENEWABLE ENERGY FRACTION: solar fraction is defined as the percentage of DHW and/or heating demand that is covered by solar thermal energy.

$$SF_{DHW} = \frac{Q_{ST,DHW}}{Q_{DHW}}$$

$$SF_{SH} = \frac{Q_{ST,SH}}{Q_{SH}}$$

$$SF_{tot} = \frac{(Q_{ST,DHW} + Q_{ST,SH})}{(Q_{DHW} + Q_{SH})}$$

Where $Q_{ST,DHW}$ is the net solar thermal energy employed, detracted of thermal losses along the pipelines and the thermal storage. The computation of this figure poses a challenge, since all the solar thermal energy is conveyed to the solar storage tank, and then used both for DHW preparation and for space heating; therefore, there is no formal way to split the total renewable energy into the two contributions. As an approximation, the contribution of the solar thermal energy to the different loads has been considered as proportional to the power delivered during the DHW and solar space heating delivery.

The same strategy is used to calculate the net amount of aérothermal (respectively geothermal) energy harvested by the heat pump that contributes to cover the heating and DHW loads.

$$AF_{DHW} = \frac{Q_{A,DHW}}{Q_{DHW}}$$

$$AF_{SH} = \frac{Q_{A,SH}}{Q_{SH}}$$

$$AF_{tot} = \frac{(Q_{A,DHW} + Q_{A,SH})}{(Q_{DHW} + Q_{SH})}$$

Finally, the renewable energy fraction is calculated as the total amount of loads to the total renewable energy (solar thermal, aérothermal and geothermal) that contributes to cover such loads. For sake of simplicity, the renewables contribution to the grid electricity used is disregarded. As a main consequence, renewable energy sources do not contribute to cover cooling loads.

$$RENF_{DHW} = Q_{REN,DHW} / Q_{DHW}$$

$$RENF_{SH} = Q_{REN,SH} / Q_{SH}$$

$$RENF_{tot} = (Q_{REN,DHW} + Q_{REN,SH}) / (Q_{DHW} + Q_{SH})$$

PENALISED FE AND SPF: we have defined penalty calculations to make sure that the same thermal comfort is achieved by all systems (based on using the convective temperature). The following conditions result in penalties being calculated for the system: $T_{DHW} < 40^{\circ}C$, $T_{SH} < 19.5^{\circ}C$, $T_{SC} > 25.0^{\circ}C$.

To fairly compare different HVAC systems though, we must acknowledge that some of them do not perform as wished and we must penalise their operation. To do that, we calculate the penalised FE and SPF: whenever the investigated system is not able to fulfil the user demand for the room temperature and DHW supply temperature, an additional energy demand, the penalty, is calculated and interpreted as an auxiliary energy demand of the heating system. The electric energy required is calculated accounting for an ideal electric system with COP (or EER) equal to average computed for the system (Haller M. Y., 2014). For more information refer to task 26 book "Solar heating systems for houses" (Weiss W., 2003).

If the temperature of the room is lower than the set point, the penalty is defined as the product of $(UA)_{building}$ (building heat loss rate) and the difference between required set temperature and actual indoor air temperature.

The penalty function is calculated for every time step and then integrated on a yearly basis. In the following, the two equations used for the heating and cooling penalties are reported:

$$Q_{PEN_{SH}} = UA_{BUI} * MAX(0, MAX(0, T_{set_H} - T_{zone}) + (MAX(0, T_{set_H} - T_{zone}) + 1)^{X_{SH}} - 1)$$

$$Q_{PEN_{SC}} = UA_{BUI} * MAX(0, (MAX(0, T_{zone} - T_{set_C}) + 1)^{X_{SC}} - 1)$$

Where

$UA_{BUI} = 30.1 + Q_{HEAT_{ave}} * 2.13$ is the building heat loss rate related to the energy level

x_{SH} is the (punishment factor) introduced by the exponent: 2 (arbitrarily)

T_{set_H} heating lower temperature limit is 19.5 °C (20.5 °C for offices)

T_{set_C} cooling upper temperature limit is 25.0 °C

The calculation of the penalty for the DHW simply calculates the missing energy to reach the set point temperature. The "punishment factor" is defined (again arbitrarily) as 1.5:

$$Q_{PEN_{DHW}} = 1.5 * \dot{m}_{DHW} * C_{p,WATER} * MAX(0, T_{set_{DHW}} - T_{DHW})$$

Although, the penalisation functions are purely subjective, as already stated, they allow to objectively comparing systems that guarantee comfort conditions, to those that do not.

These three electric energies are added to the system Final Energy, and shown in the $FE_{penalised}$.

The penalised SPF ($SPF_{penalised}$) is calculated using the $FE_{penalised}$.

UTILITY ENERGY BILL: as for the PE figure, the total energy bill is another method to aggregate the contributions of the different energy sources to covering the building's energy uses:

$$UEB = (E_{DHW} + E_{SH} + E_{SC}) \cdot Cost_E + (HCV_{DHW} + HCV_{SH} + HCV_{SC}) \cdot Cost_{fuel}$$

All the above mentioned figures are calculated for:

- Space cooling loads only
- Space heating loads only
- DHW loads only
- Space heating and DHW loads
- Space heating, cooling and DHW loads
- Space heating, cooling and DHW loads + ventilation electricity consumption

This approach allows to highlight the weight of the different loads' contributions to the total energy consumption of the building related to the HVAC system.

4.3 Performance indicators for solar thermal field

SOLAR THERMAL SYSTEM EFFICIENCY: the efficiency of the solar thermal system is defined as the ratio of the obtained useful heat divided by the irradiation (see e.g. VDI 6002-1 (2004)) on the collector plane. Depending on how the useful heat is defined and where it is measured, stagnation periods, pipe losses, actual weather conditions and interdependency to the conventional heating system may be taken into account (Task 44, Deliverable B1).

In this report, the useful energy delivered to the solar thermal energy storage is considered, accounting for all the irradiation incident on the collector plane when the solar pump is running or during stagnation periods. Thus, the solar thermal system efficiency can be defined as:

$$\eta_{ST} = Q_{ST,store} / I_{coll}$$

GROSS SOLAR YIELD: using the net solar energy delivered to the storage tank, we calculated the solar field GSY:

$$GSY_{ST} = Q_{ST,store} / Area_{coll}$$

In addition, stagnation periods are accounted for.

4.4 Performance indicators for photovoltaic field

The FE and PE figures described account for the PV electricity produced and instantaneously consumed by the H&C system: the PV electricity is subtracted by the electricity consumption if it is produced when H&C system operates. In many cases, this is a small fraction of the total PV production. Therefore, a dedicated section of the database shows the total PV electricity consumption, how much of this electricity is self-consumed and how much is fed into the grid. Note that the self-consumption is based on a time step of 1 hour (consumption as well as PV electricity production). The energy bill accounts only for the electricity taken from the grid. Incentives and renewable based funding in general are disregarded as they differ by country.

The computation of the PE utilization accounts only for the PV electricity used by the HVAC systems. It is easy to recalculate the total PE consumption by subtracting the

specific amount of PV electricity, dependent on the boundary considered (the entire building or the grid as a whole).

4.5 Performance indicators for economic analysis

This section presents the economic analysis of the systemic Renovation Packages in terms of total costs of ownership (investment + running) over a 30 years period. The latter have been adopted to permit a direct comparison with the LCA study, and to provide a spendable figure that final users and customers can easily understand.

Besides clear advantages from the environmental and technical point of view, investment costs are a bottleneck for a widespread diffusion of systemic Renovation Packages. Thus, we must “uncover” the best solutions from both the technical and economic point of view.

INVESTMENT COSTS: The up-front cost a customer pays when adopting a systemic Renovation Package is defined as the total cost of ownership TCO [€/m²] calculated according to the Net Present Value (NPV) method, which takes into account all costs during the period of analysis and in particular:

- initial investment costs I_0 ;
- replacement costs C_r .
- operation linked payments (maintenance costs, insurance, taxes) C_m ;
- consumption linked payments (final energy costs) C_{fe} ;

The advantage of adopting this approach is that the cost-effectiveness of a given system is not defined in relative terms with respect to a reference system, on the contrary, it is evaluated in terms of specific energy price that has been paid by a final user during the life time of the building itself.

For sake of simplicity, the calculation approach adopted here assumes that the investment costs and replacement costs can be born with own budget. Whenever this condition does not occur, these costs are funded through a bank loan, and the interest rates must be accounted for, together with inflation rates. For the same reasons, incentive schemes are disregarded.

In order to compare two investments representing two different energy system variants, a common economic timeframe must be defined. We decided to use a timeframe of 30 years since passive and active solutions are entailed in the Renovation Packages.

The Renovation Package lifespan τ is in general shorter than the calculation period N (Figure 9). An estimation of τ is not easy to derive and most of the times it can be based only on personal experience. Annex IV reports on the assumptions adopted. In the database published, the user is free to input such value for each of the subsystems individuated.

When a system completes its lifespan, a replacement occurs. From an economic perspective, this reflects in a series n of replacements each of them resulting in a replacement cost C_r . Since replacement costs occur at different times than the initial investment cost, inflation interest i has to be considered as follows:

$$\begin{aligned}
 C_{r,0}^{(1)} &= I_0 \cdot (1 + i)^{0 \cdot \tau} \text{ , the initial investment} \\
 C_{r,0}^{(2)} &= I_0 \cdot (1 + i)^{1 \cdot \tau} \text{ , if } 1 \cdot \tau < N \\
 &\dots \\
 C_{r,0}^{(n)} &= I_0 \cdot (1 + i)^{n \cdot \tau} \text{ , if } n \cdot \tau < N
 \end{aligned}$$

The total replacement cost $C_{r,0,N}$ is the sum of the single replacement costs that have been faced during the period N :

$$C_{r,0,N} = \sum_{j=0}^n C_{r,0}^{(j)} = I_0 \frac{1 - (1+i)^{\tau \cdot n}}{1 - (1+i)^{\tau}}$$

During the lifespan τ , it is assumed that the system has a linear depreciation of the investment cost I_0 or the replacement cost C_r . At the end of the economic analysis period N , a positive residual value RV might occur. The actualized residual value RV_0 of a system can be calculated as follows:

$$RV_0 = \frac{RV}{(1+i)^N} = I_0(1+i)^{\tau \cdot n - 1} \left(1 - \frac{\tau \cdot n - 30}{\tau}\right)$$

Hence, the net total replacement cost $C_{r,N}$ is the difference between the replacement cost $C_{r,0,N}$ and the actualized residual value RV_0 of the system.

$$C_{r,N} = C_{r,0,N} - RV_0$$

Since little information from comparable subjects is available, the definition of maintenance cost C_m is also not an easy task. For sake of simplicity, a benchmark yearly cost is here established as a percentage c_m of the initial system investment cost, in the range of 1-3%/year.

$$C_{m,N} = \sum_{j=1}^N C_m \cdot (1+i)^j$$

The yearly energy related cost C_{fe} can be calculated on the basis of the cost of the final energy annualised by means of the rate of change of the energy costs with time:

$$C_{fe,N} = \sum_{j=1}^N C_{fe} \cdot (1+i_e)^j$$

Once the initial investment cost I_0 , the total final energy cost $C_{fe,N}$, the maintenance cost $C_{m,N}$ and the net replacement cost $C_{r,N}$ related to the economic analysis period N have been computed, the total cost of ownership TCO can be easily calculated as:

$$TCO = I_0 + C_{fe,N} + C_{m,N} + C_{r,N}$$

In the database, the TCO is also reported in terms of annual cost (€/y) and annual costs per unit surface of living area (€/m²/y), over 30 years.

In addition, simple investment costs and annualised investment costs, are reported a basic way to compare initial (“entrance”) costs to be born for the renovation process.

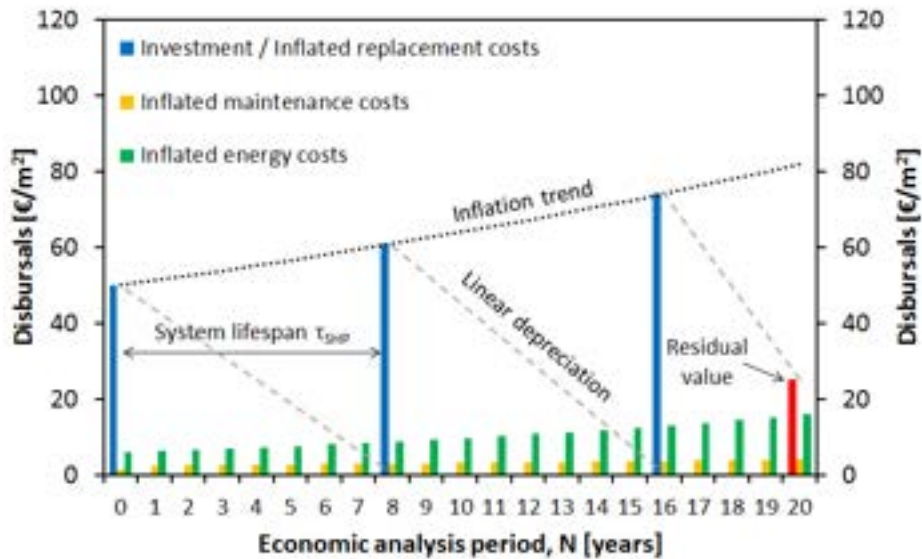

Figure 9 - Graphical representation of the periodicity of disbursements and interest related costs during an economic analysis period.

5 Energy sources and sinks for “neutral” DHC networks

A thermal network with a very low temperature fulfils completely the fundamental idea of district heating:

“to use local fuel or heat resources that would otherwise be wasted”.

Because of the very low working temperature, it is able not only to recover that waste heat with very low “quality” that is available around a city but it also minimize the heat losses to the ground.

In order that a heat/cold market could arise, three elements are mandatory and must be available locally:

- the heat/cold demand;
- cheap and adequate heat/cold sources;
- the infrastructure (the thermal network) used as market place that allows buyers and sellers to exchange this kind of service.

According to Frederiksen and Werner [10] the main local resources that are generally used in traditional district heating consist of:

- excess heat from thermal power plant (CHP);
- excess heat from industrial processes (e.g. fuel refineries);
- usable heat from waste incineration and biomass-fired plants;
- geothermal heat sources.

These traditional heat sources can be also used for “neutral” DHC networks with additional benefits:

- improving of the efficiency of some thermal power plants. For instance with the decreasing of the condenser temperature in systems based on the Rankine cycle;
- electricity production from sources available at a not very high temperature via conversion units like ORC systems.

Moreover, “neutral” DHC networks allow also:

- to recycle waste heat available at a temperature level that is not suitable for traditional district heating (e.g. from data centers, bakeries, refrigeration plants, air conditioning chillers);
- to exploit renewables source through different technologies (e.g. with solar thermal collectors, extraction of environmental heat via heat pumps).
-
- The main Pros and Cons of “neutral” DHC networks for what concerns the distribution technology are:
 - (+) low thermal and mechanical stress of the pipes due to the low temperature;
 - (+) utilization of pipes without insulation with the advantages linked to the avoid deterioration of the polyurethane (PUR) foam and change of conductivity due to infiltration and diffusion of gases;
 - (+) utilization of flexible pipes in plastic materials with several advantages due the reduction of the number of joints, simplification in the joint installation, absence of pipe corrosion due to the amount of oxygen in the water, easy adaption to various geometries and reduction of the time for installation by rolling out the flexible pipes;
 - (-) higher pumping cost due to the fact that to deliver the same amount of thermal power it is needed a higher mass flow rate; this because of the smaller ΔT between the supply and return pipes compared to traditional DH systems;
 - (-) higher pumping cost compared to traditional DH systems because the water viscosity increases at lower temperatures;
 - (-) more complicated substation due to the integration of a heat pump.
 -
- In the following paragraphs different potential sources and sinks that can be exploited perfectly with a “neutral” DHC network are described.

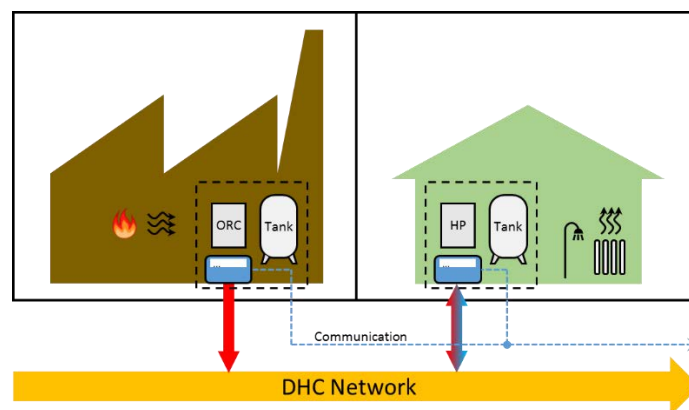

Figure 10: Concept of the “neutral” DHC network.

5.1 Waste heat from industry

Waste heat is commonly rejected in air around a city contributing to the urban heat-island effect. This source is very important because it is locally available and contribute in a greater energy independence from other countries.

On one hand, according to the Table 9 a big amount of common industrial process require heat at a temperature levels that does not exceed $100 \div 150$ °C. On the other hand, if we think at the end of these processes, a big amount of heat is wasted at lower temperature. This because of thermal losses, cooling of goods and equipment, washing and sterilizing of components.

Moreover, if we consider the cold chain for the food preservation a big amount of waste heat is available locally from refrigeration machines of supermarkets and storehouses.

Thanks to the connection to a “neutral” DHC network these companies could reach a low temperature required in the cooling phase of the process and also can economically profit from their waste heat provided to the network.

The other positive aspect is that factories that work with “low temperature” processes are quite distributed in small and medium cities. Conversely, energy intensive industries with waste heat available at high temperature are usually more concentrated in industrial parks outside the main residential area of a city.

However, when heat is available at very high temperature, for instance from iron, steel, cement and glass industries, ORC units based on a closed Rankine cycle can be installed as cogeneration units to produce both electricity and heat. Within the EU FP7 project PITAGORAS this concept is been demonstrated in Brescia (Italy) where waste heat available at a temperature higher than 1000 °C is recovered from the fumes of an Electric Arc Furnace of a steel mill and an ORC unit (2,1 MWe) has been installed for power generation and for supplying the local district heating network.

Table 9: Temperature ranges for different industrial processes [17]

INDUSTRIAL SECTOR	PROCESS	TEMPERATURE[°C]
Food and beverages	Washing	80 – 150
	Pasteurization	80 – 110
	Sterilization	130 – 150
	Drying	130 – 240
	Cooking	80 – 100
Mining	Hot water and steam	50 – 180
Chemical	Heat treatment	150 – 180
	Boiling	95 – 105
	Distillation	110 – 300
	Drying	150 – 180
Paper	Bleaching and drying	130 – 180
Textile	Washing	80 – 100
	Heat treatment	80 – 130
	Bleaching	60 – 100
	Dyeing	100 - 160
Industrial cleaning	Steam Washing	150
Commercial sector	Air conditioning	180
All	Electricity generation/Polygeneration	250-300

5.2 Wind and Solar Energy

For what concerns these kind of renewable energy sources, the following solutions can be implemented:

- large electric boilers and heat pumps can use the surplus of wind power to generate heat or cold. The profitability of this solution could come from the balancing services of the electrical grids beyond the trade of heat and cold;
- central or distributed solar collector fields can feed a district heating network as it is shown in Figure 11 and Figure 12. In this case, short-term or seasonal storages are

crucial to cope with the deviating solar heat production during the course of one day, several days or even of a year.

By using a “neutral” DHC network where there is not the need of high temperatures, uncovered solar thermal collectors can be installed for this purpose with the reduction of investment costs.

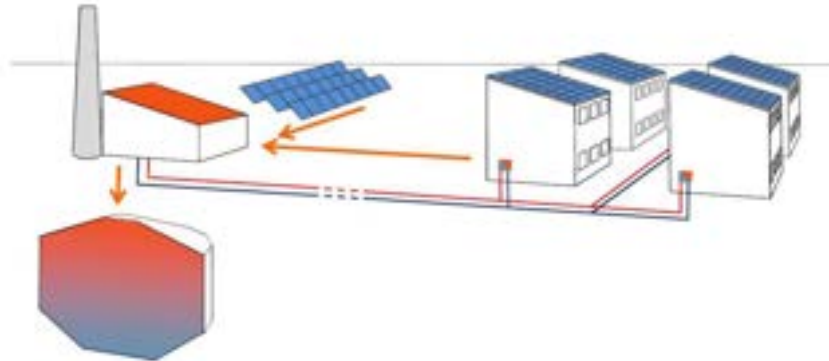

Figure 11: Central solar district heating system [18].

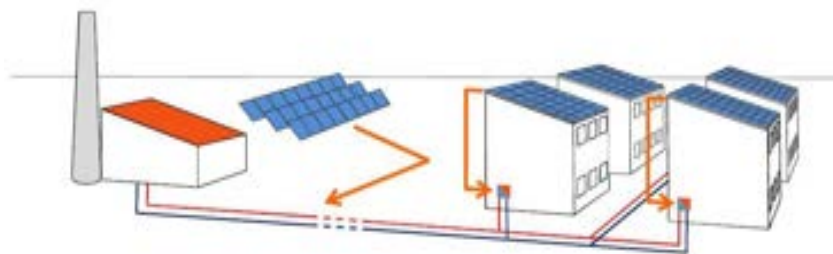

Figure 12: Distributed solar district heating system [18].

5.3 Environmental heat sources/sinks

The main types of environmental heat sources/sinks includes resources with a very low “quality” of thermal energy (low exergy content). These can be easily exploit via a “neutral” DHC network. The main technology solutions that are applied for this kind of heat sources/sinks are heat pumps and heat exchangers for the “free cooling” concept. The main types of environmental heat sources/sinks are:

- *ambient air*: on one hand this source is excellent in terms of availability, on the other hand the main problems are linked to the daily and seasonal temperature variation;
- *exhaust air and waste heat from air treatment units*: big buildings like hospitals, schools, offices and shopping mills are potential sources around a city.
- *sea, lake or river water*: this kind of source are generally available around a city. This came also from the history. Civilizations tended to grow up mainly in river valleys for the access to a reliable source of water for agriculture and human needs.

In Switzerland, for example the Lake Geneva is used for cooling and heating the Sécheron-Nations district in the northern part of the Geneva since 2009. Water is collected from the bottom of the lake at a depth of about 40 meters with a temperature that has a yearly variation between 6 and 10 °C [14].

In Italy, the area “Complesso della Torre” in Savona with 1 hotel, 193 flats, 20 offices and 31 shops is supplied by sea water with a temperature that change between 14°C in winter and 24°C in summer. The water return to the source with a temperature difference of about 3° C [19].

- *ground*: closed loop heat exchangers can be used in large borehole fields to extract/reject heat from/to the ground. It is important to design accurately these systems to allow the source to be able to “restore” its initial conditions.
- *groundwater*: this source is generally available in many part of the world at a depth less than 200 meters and with constant temperature throughout the year.

Two different technologies can be used: *closed loop heat exchangers* without extraction and *open loop systems* with extraction. When there are available suitable conditions in the subsoil this system can be also used as a thermal storage. The concept is called “Aquifer thermal energy storage” (ATES) and its development started in the Netherlands in the early 1980s. The groundwater is extracted in summertime from the “cold well” for space cooling and it is injected in the “warm well” as it is shown in Figure 13. In winter, the flow direction is reversed. Consequently, the heated groundwater is extracted from the “warm well” and it is injected in the “cold” one [20].

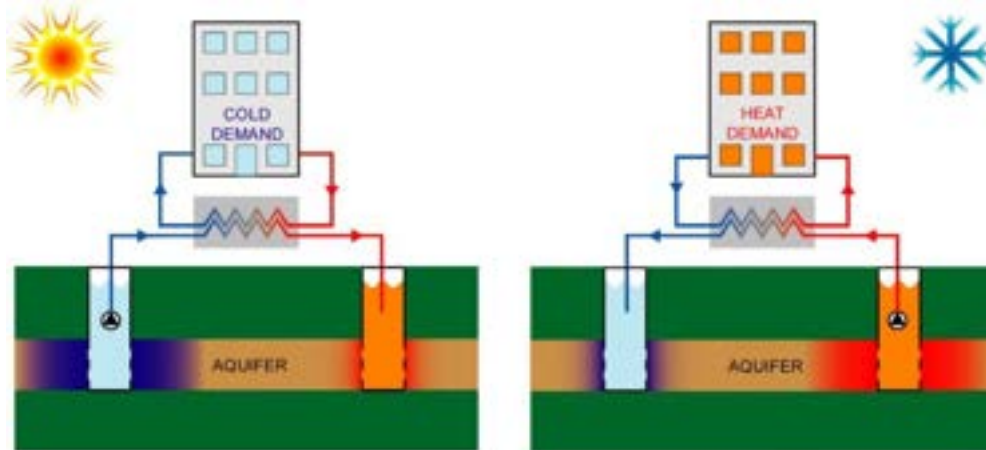

Figure 13: Aquifer Thermal Energy Storage concept [20].

In Italy, the company COGEME has started to use groundwater with an average temperature between 12÷13°C to feed some small DHC network. Two case studies are located in the small towns of Berlingo and Torbole Casaglia in the province of Brescia [21].

- *sewage*: this source has a big potential in terms of replicability. The main advantage is due to the limited daily and yearly variation of the temperature of this sources as it is shown in Figure 14. Heat can be recovered from sewers in two different ways: with the installation of gutter-shaped heat exchangers on the bed of the sewer or an external heat exchanger with an upstream pump and filter installation [22].

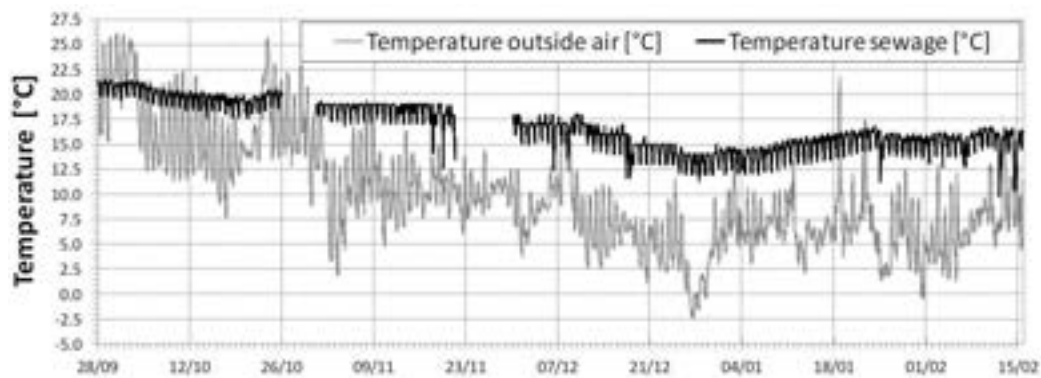

Figure 14: Time series of the hourly average temperature of the sewage and of the outside air monitored in Bologna between 2006-2007 [23].

6 Role of short-term and seasonal storages in “neutral” DHC networks

The storage idea is to produce heat or cold while the production conditions are as effective and favourable as possible, e.g. production of solar thermal during the day or production of electricity while electricity prices are high in relation to CHP plants.

The storage helps detaching the production from the demand, which is useful in systems with high fluctuations of energy production. The storage thereby increases the flexibility to utilize other sources of energy that is not in sync with the demand.

The basic principle of separating the production and demand in time, can be either on a short-term basis or on a seasonal time scale. While small-scale storages for very short periods (e.g. only on hourly basis) may be useful on local level, the term “short-term storages” is used in this report for storages from daily variations up to weekly storage capacity. “Long-term storages” refer to storage capacities that can account for seasonal variations.

The capacity of short-term and long-term storages in this regard, depend on the system properties (including production technologies and specific demand) to which the storage is connected.

This document refers mainly of some case studies of Denmark where these technologies has been successfully implemented in the last years.

6.1 Categorization of heat storages

The choice of a storage technology is highly dependent on the context in which the storage is to be implemented.

Storages are in general divided according to three main categories:

- Temperature level
- Time length of storage
- Status of material

The main categories are described in the following paragraphs, dividing the categorization of storages into several subcategories. An overview of the categories is seen in Figure 15.

State of the storage medium

As shown in Figure 15, the different storages can be divided into four physically different technologies:

Sensible storage: use the heat capacity of the storage material. The storage material is mainly water due to its favourable properties e.g. having a high specific heat content per volume, a low cost and being a non-toxic media.

Latent storages: make use of the storage material’s latent heat during a solid/liquid phase change at a constant temperature.

Chemical storages: utilize the heat stored in a reversible chemical reaction.

Sorption storages: use the heat of ad- or absorption of a pair of materials such as zeolite-water (adsorption) or water-lithium bromide (absorption).

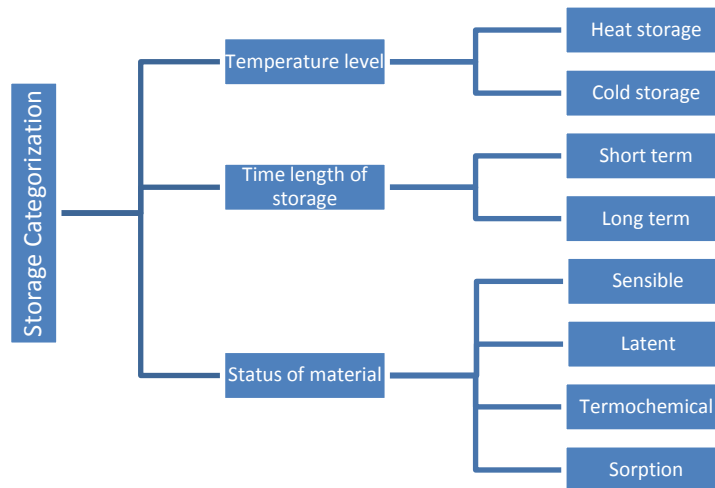

Figure 15: Categorization of storages according to temperature level, time length of storage and use of material.

Properties of selected storage types

The following large-scale storages are investigated:

- Steel tanks (centralised “daily” water storages)
- Water pit storages (centralised “daily” to “seasonal” storages)
- Borehole storages (centralised “daily” to “seasonal” storages)

A thing to consider in a given context will be whether it is more feasible to store at

- a) low temperatures (because the investment in insulation can be reduced and/or more excess heat may be available at low temperatures)

or

- b) high temperatures (because this will mean higher energy density and thereby a smaller storage volume for the same energy content).

This will of course depend on the available heat supply (i.e. high temperature directly available or not).

Some large-scale storages occupy free space whereas others can be placed below recreational areas. In case storages has to be located in the outskirts of (or outside) the city, transmission pipes have to be included.

Principles of the investigated storage technologies

A Technology Catalogue from The Danish Energy Agency; “Technology Data for Energy Plants - Generation of Electricity and District Heating, Energy Storage and Energy Carrier Generation and Conversion” [25] from 2014 shows in a figure the principle of the three types of storage. The figure is reproduced as Figure 16 for storage tanks, pit storages and borehole storages.

6.2 Storage tanks (TTES)

Cylindrical steel tanks are also known as TTES, which is an abbreviation of tank thermal energy storage. This type of storage can be located above ground level, which is the most common case, but it can also be located below ground level. This is for instance seen in Germany, where steel tanks are sometimes used even as seasonal storages in connection to e.g. solar thermal, supplying smaller residential areas.

The tank is typically made of stainless steel, concrete or glass-fibre reinforced plastic and contains water as storage material. Insulation of the storages is determined according to environment and application. For steel tanks, 30 – 45 cm of mineral wool is typically used to keep heat losses low.

The storage capacity depends on the temperature difference in the storage. In the steel tank is seen a vertical temperature distribution, where the hot water is in the top. The temperature supplied to the storage is typically the temperature produced from e.g. solar thermal, and is in most installations capable of supplying the supply temperature in the DH network.

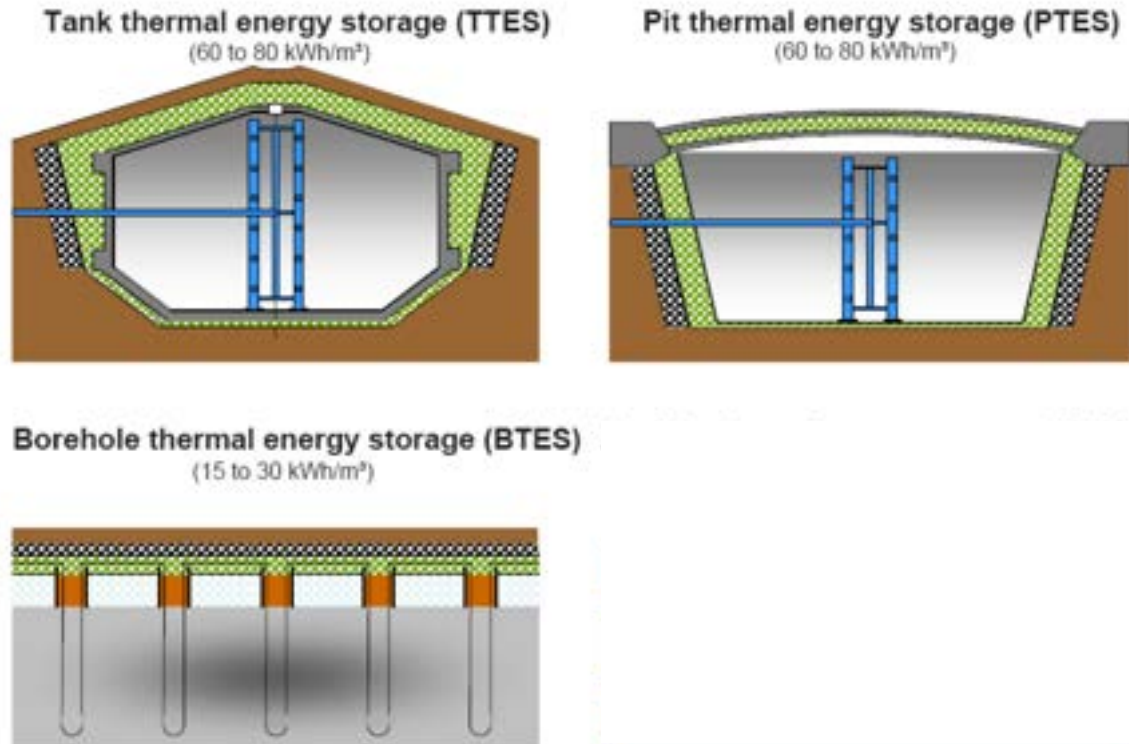

Figure 16: Concepts of three different thermal energy storages.

The temperature distribution in the storage is managed by a pipe system, shown in Figure 16 by means of the blue pipes. This system serves to keep the efficiency of the storage as high as possible.

If the storage is placed as steel tank above ground, it can be dominant in the landscape. If the storage is below ground level, it is possible to use the area for other purposes.

It is possible for some tanks (with several outlets) to extract heat at different heights. In such tanks water at the desired demand temperature level can be used (e.g. from the middle part of the tank) while maintaining high temperature water in the top of the tank if the temperature in the top of the tank is higher than what is needed. This is especially useful if you operate with very large storages, where it is important to maintain a good thermal stratification, meaning a high temperature difference in the tank from top to bottom in order to avoid having a large volume of too low temperature to be utilised in the network.

Storage tanks economics of scale

Figure 17 shows the specific investment costs for cylindrical steel thermal storage tanks as a function of their volume. This storage technology shows very good economics of scale for tanks in the size of 0 – 5,000 m³, but for much larger tank sizes the cost curve is quite flat. The data in the figure is for TTES in Denmark. No data is shown for TTES larger than 10,000 m³ since this is quite uncommon although tanks up to 60,000 m³ exist in Germany.

The heat losses also depend on the volume and are estimated to be on the order of 2 % per week for 500 m³ storages and 1 % per week for 5,000 m³ storages (PlanEnergi, 2013).

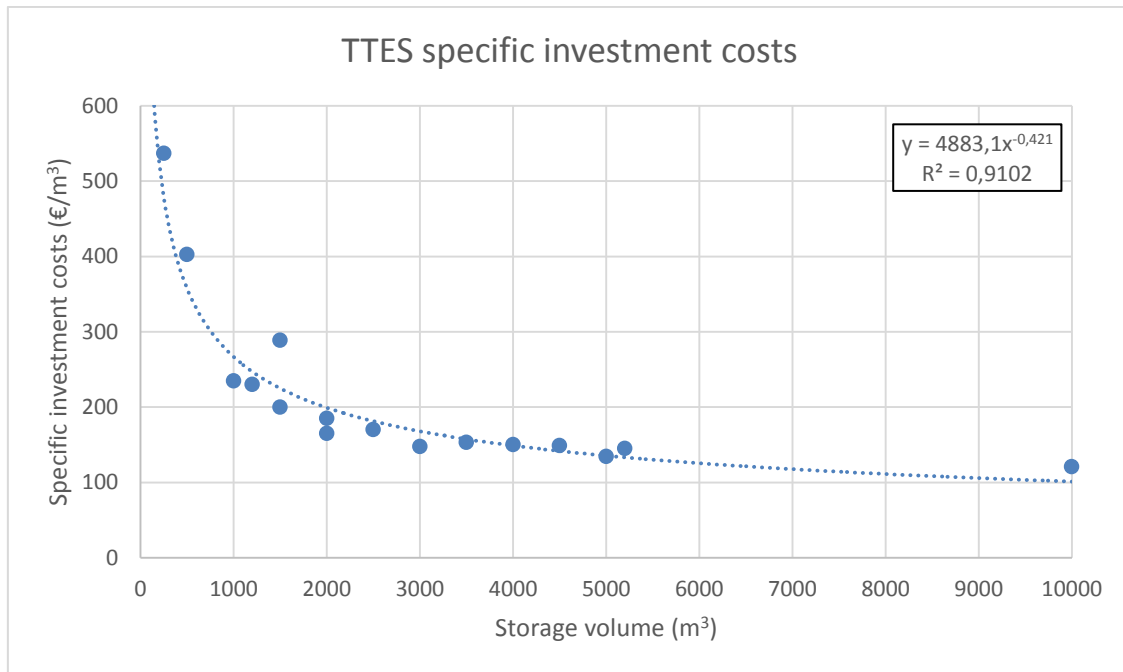

Figure 17: Economics of scale for a few TTES storages in Denmark. Data from (Danish Energy Agency, 2014) [25] and (PlanEnergi, 2013) [26].

6.3 Pit Thermal Energy Storage (PTES)

There are different technical concepts for seasonal heat storage. One of the concepts is the pit thermal energy storage (PTES), which has been developed since the 1980s at the Technical University of Denmark where a test storage was built. The first pilot demonstration storage was established in Ottrupgård, Denmark in 1995 (1,500 m³) and the second pilot demonstration storage was constructed in Marstal, Denmark in 2003 (10,000 m³). The first full scale storage was built in Marstal 2011-2012 (75,000 m³), and the second full scale storage in Dronninglund, Denmark during 2013-2014 (60,000 m³) – both in connection to large solar collector fields, covering up to around 50 % of the district heating demand.

Today the largest PTES is constructed in Vojens, with more than 200,000 m³ capacity in connection to a 70,000 m² solar collector plant. The seasonal storage ensures that around 40 % of the annual district heating demand can be covered by solar heat.

Pit thermal energy storage is a rather inexpensive storage form per m³, developed in conjunction with solar heating. In Denmark 6 PTES are already in place and more are expected to follow.

A pit thermal energy storage is a large pit dug in the ground fitted with a membrane, typically of plastic on the bottom and walls of the pit to keep the storage from leaking. Like for the TTES, the PTES also uses water as the storage medium. The pit is covered with an insulating lid to reduce the energy losses from the storage, which can float on the surface of the water. The side walls and bottom of the storage are often not insulated because the ground soil has an insulating effect itself and the additional costs for improving the insulation are not feasible considering the reduced energy losses.

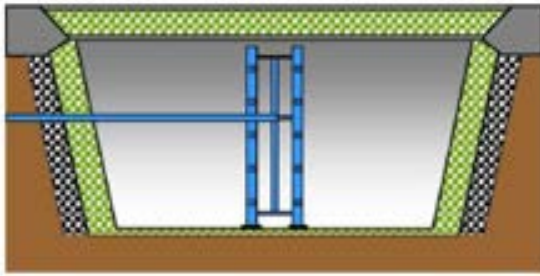

Figure 19: Cross sectional drawing of a PTES and picture of a PTES construction in Marstal (PlanEnergi 2012).

Pit Thermal Energy Storage (PTES) economics of scale

Pit thermal energy storages have significant economies of scale benefits as shown in Figure 20. They are primarily suitable as large-scale facilities and the tendency has been that every new PTES that is constructed is larger than those already existing. For large scale heat storage, PTES has a considerably lower specific investment costs than TTES.

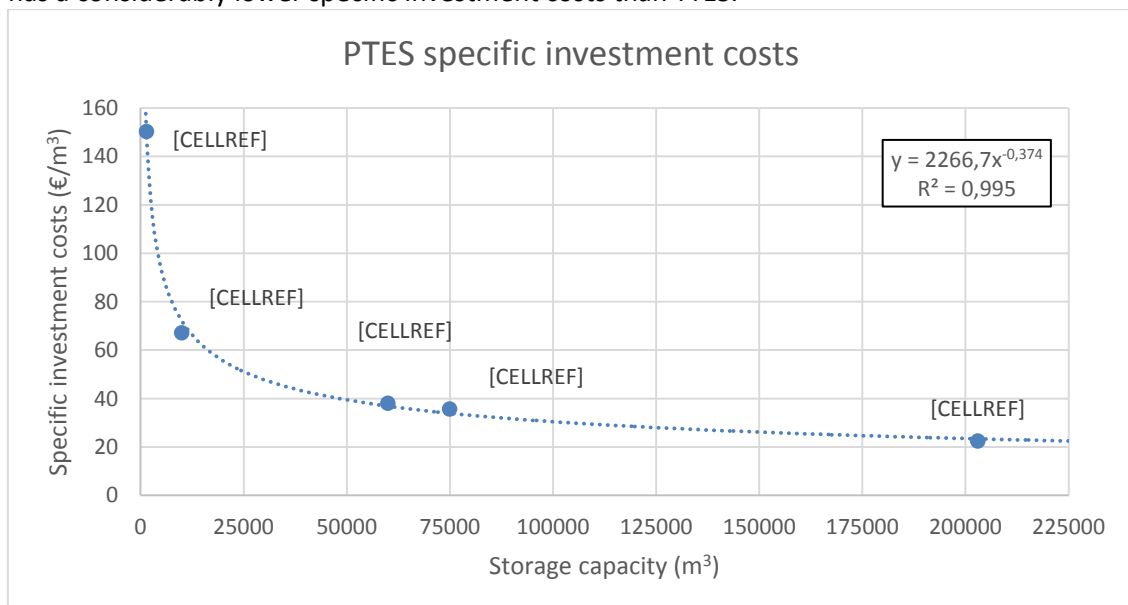

Figure 20: Economics of scale for PTES systems. Data from (PlanEnergi, 2013) and (PlanEnergi, 2015).

6.4 Borehole Thermal Energy Storage (BTES)

A borehole thermal energy storage (BTES) consists of a number of boreholes dug in the ground in which pipes are placed. The storage is charged by pumping hot water through the pipes in the boreholes, which then transmits heat to the ground surrounding the boreholes. The storage medium here is the soil surrounding the boreholes and not the water in the pipes which is just a transfer medium. There is usually a layer of insulation on top of the boreholes to reduce heat losses.

Figure 21 shows a three-dimensional drawing illustrating how the BTES is located in the ground. When discharging, cold water is pumped through the pipes in the boreholes and the stored energy in the ground is absorbed in the water and can be used for heating.

BTES is not as common a technology as TTES and PTES. The first BTES in Denmark was constructed in 2012 and put in operation in Brædstrup for district heating supply in conjunction with a large solar thermal capacity. The facility consists of 48 boreholes of 45 m in depth with a total storage volume of 19,000 m³. At the time of construction, this BTES was the largest BTES facility for district heating in Europe.

The capacity of BTES can be anything between one borehole for the use of one single household to large scale storages of several hundred boreholes. The specific capacity of the systems is estimated to being 15-30 kWh/m³ of storage material (DEA Technology Catalogue 2012). The efficiency depends on the size of the storage. For small systems the efficiency can be as low as 60 % where for large systems of above 100,000 m³ the efficiency can reach 85 - 90 %.

The charge and discharge effect is limited by the convection from or to the storage material in the ground and the transferring medium in the ground pipes and this is why BTES mainly is used for base load capacity. The investment costs are sensitive to the ground properties of the location where the storage is to be constructed. Since it requires many boreholes for large facilities, any difficulty in drilling the boreholes can increase the investment costs significantly.

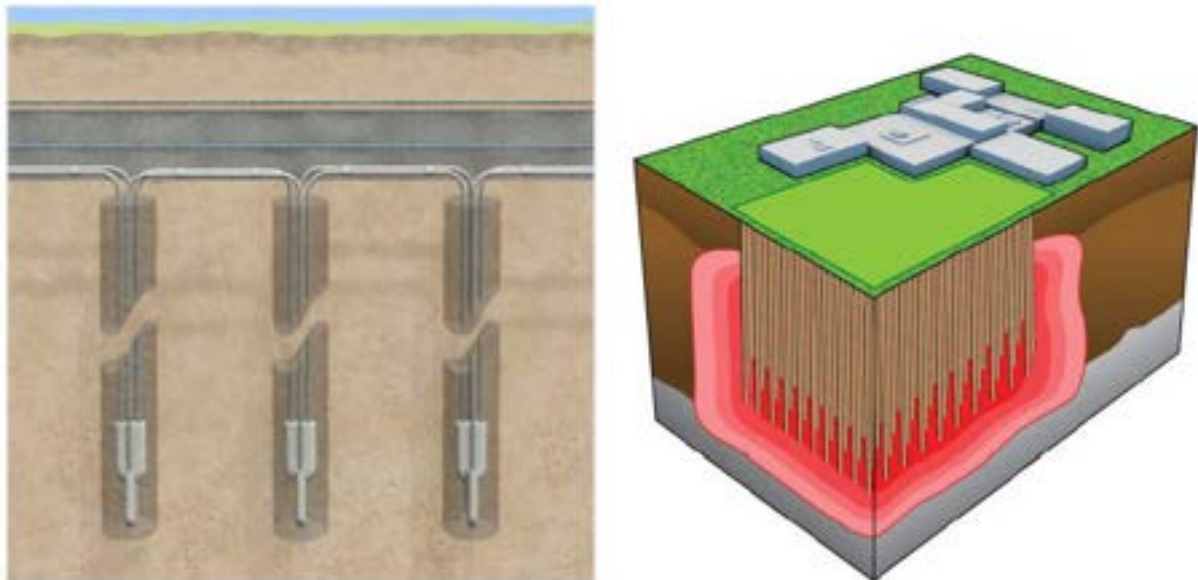

Figure 21: Cross sectional drawing of a BTES and Three-dimensional drawing of BTES
www.bbeatty.com/geothermal.php

Borehole Thermal Energy Storage (BTES) economics of scale

The storage volume of borehole thermal energy storage is not as well defined as for TTES and PTES. It is often assumed that 3 m³ of soil volume BTES are equivalent to 1 m³ of water storage volume because the soil has a lower specific heat capacity than water [27]. After making this conversion from soil volume to water equivalents, PTES storage volume can be compared directly with the volumes of TTES and PTES.

As shown in Figure 22, BTES does not have as well-defined economics of scale as TTES and PTES. The specific investment cost is around 40 €/m³ water equivalent for four out of the five systems in the examples used. An increased amount of data points would provide a more reliable estimate of the economics of scale of BTES. The investment cost for such systems is also location-specific, as it relies on the geological suitability of the soil for drilling the holes and on the composition and permeability of the soil with regard to heat exchange and storage.

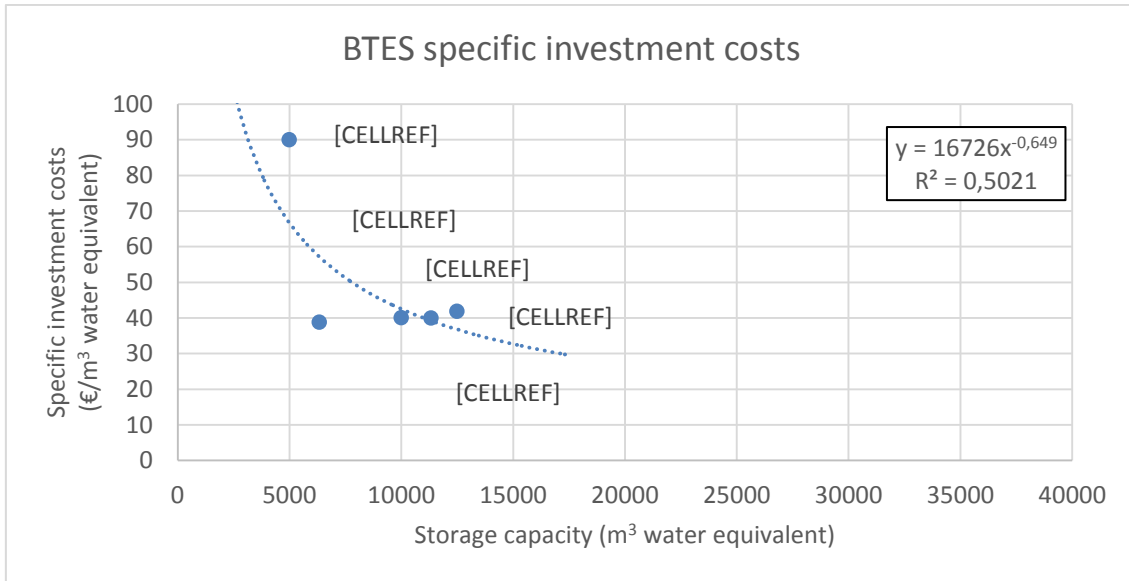

Figure 22: Economics of scale for BTES systems. Data from (PlanEnergi, 2013) and (CIT Energy Management, 2011).

Summary and comparison

In Table 10, the key parameters mentioned in the sections of the investigated storage technologies are summarized to give an overview and comparison between the technologies. For large scale TES, PTES has the advantage of lower specific investment costs compared to TTES, which are similar in many other characteristics, they both use water as storage medium, have relatively high efficiencies and high charge/discharge capacities. The area requirements are the most significant disadvantage of PTES. BTES can be implemented almost independent of the geological properties. The BTES has relatively high investment costs due to the number of boreholes. Another issue with BTES is that it has a relatively low charge/discharge capacity, which can be a problem depending on the specific application for it to be used in.

Table 10: a summary of the key properties for TTES, PTES and BTES. Reproduced from Solar District Heating Guidelines, fact sheet 7.2 and the Danish report "Udredning vedrørende varmelagringssteknologier og store varmepumper til brug i fjernvarmesystemet".

Type	TTES	PTES	BTES
Storage medium	Water	Water (Gravel-water*)	The soil surrounding the boreholes
Specific capacity [kWh/m ³]	60 - 80	60 – 80 30 – 50 for gravel-water	15 - 30
Geological requirements	- stable ground conditions - preferably no groundwater - 5 – 15 m deep	- stable ground conditions - preferably no groundwater - 5 – 15 m deep	- drillable ground - groundwater favourable - high heat capacity - high thermal conductivity

			<ul style="list-style-type: none"> - low hydraulic conductivity ($k_f < 10^{-10}$ m/s) - natural groundwater flow < 1 m/a - 30 - 100 m deep
Application	Short time/diurnal storage, buffer storage	Long time/seasonal storage for production higher than 20.000 MWh Short time storage for large CHP (around 30,000 m ³)	Long time for DH plants with production above 20,000 MWh/year
Storage temperatures °C	5 - 95	5 - 95	-5 - 90
Specific investment costs [DKK/m ³] and [EUR/m ³]	800 – 1,500 DKK for TTES above 2,000 m ³ 110 – 200 EUR/m ³	150 – 300 DKK for PTES above 50,000 m ³ 20 – 40 EUR/m ³	150 – 300 DKK for PTES above 50,000 m ³ water equivalent incl. buffer tank 20 – 40 EUR/m ³
Advantages	High charge/discharge capacity	High charge/discharge capacity Low investment costs	Most underground properties are suitable
Disadvantages	High investment costs	Large area requirements	Low charge/discharge capacity

7 Classification of the thermal network distribution configurations

Different kind of distribution configuration can be applied in district heating and cooling systems. As a consequence the network topology could results with the following structures that are shown in the following figures:

- *branched*: when generally developed for the connection of the generation plant is connected with a big customer;
- *ring*: where each building can be potentially supplied from both direction of the network;
- *meshed*: when a lot of buildings are connected in a high density context with a big improvement of the reliability of the system.

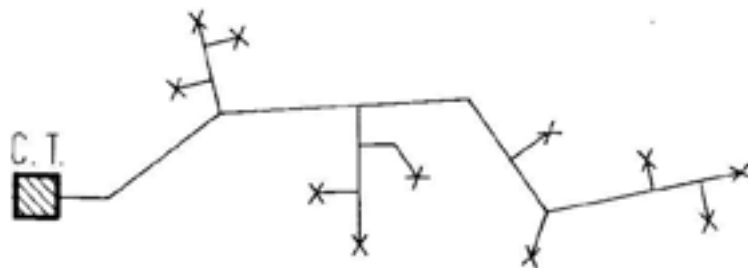

Figure 23: One line representation of a *branched* network supplied by one generation plant (C.T.) [24].

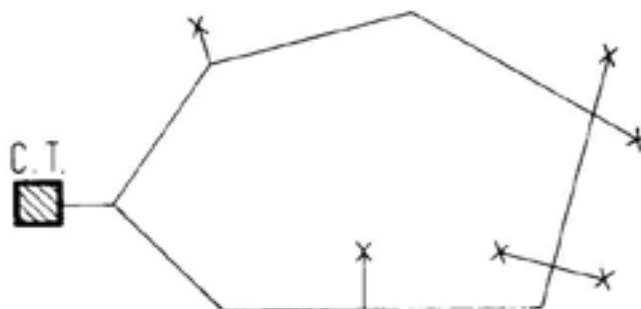

Figure 24: One line representation of a *ring* network supplied by one generation plant (C.T.) [24].

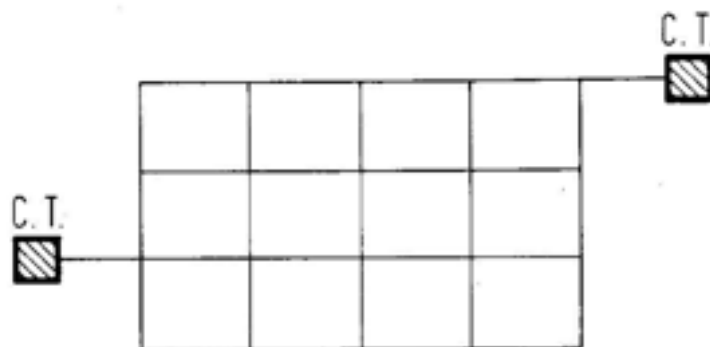

Figure 25: One line representation of a *meshed* network supplied by two generation plants (C.T.) [24].

7.1 Two pipes in counterflow

This kind of solution has been widely applied in traditional DHC networks. The network pump must be sized to overcome the overall pressure drops of the farthest user. The main pros and cons are:

- (+) less length of the overall pipe installed with respect to inverse return distribution;
- (+) the mass flow rate decrease after each user substation. Thus, it is possible to reduce gradually the diameter of the main pipe and its cost;
- (+) each user along the distribution is supplied at the same temperature;
- (-) it is important to design accurately the circuit and to balance it by inserting balancing valves to reproduce for each user the same pressure losses of the farthest user;

In Figure 26 it is shown a scheme of this kind of configuration where a heat/cold generation system supply the network.

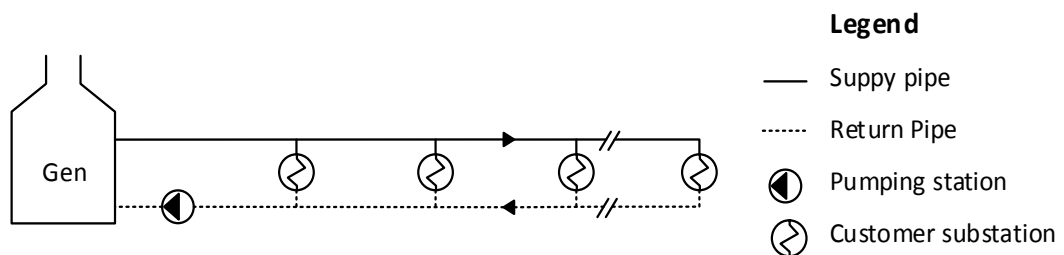

Figure 26: Simplified scheme of the two pipes in counterflow distribution configuration.

7.2 Two pipes in parallel flow (with inverse return)

The main feature of this configuration is that each user is connected to the network in a way to have an equal pipe length with respect to the position of the production plant. In this way, the circuit results naturally balanced without the installation of balancing valves.

On one hand, this kind of solution has not been widely applied in traditional DHC distribution. Moreover, it is commonly applied in commercial buildings where heating and cooling demand occur simultaneously. This solution, commonly called water loop heat pump systems (WLHP), allow recycling waste heat and include both the heat source and the dissipation unit connected in parallel with the main loop.

The main pros and cons are:

- (+) the circuit results naturally balanced;
- (+) each user along the distribution is supplied at the same temperature;
- (+) the mass flow rate decrease after each user substation. Thus, it is possible to reduce gradually the diameter of the main pipe and its cost;
- (-) a greater length of the overall pipe installed with respect to the other solutions presented in this document;

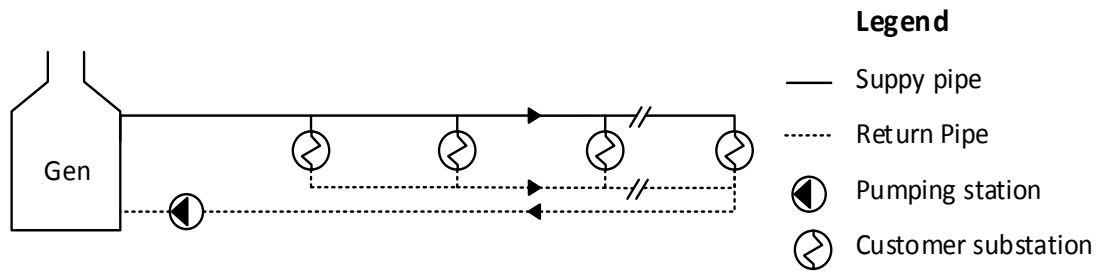

Figure 27: Simplified scheme of the two pipes in parallel flow distribution configuration.

7.3 One pipe distribution

From a literature review seems that this kind of solution has not been applied in traditional DHC yet. However, it is sometimes used in heating distribution system for the residential sector. The main pros and cons of this solution are:

- (+) less pipe installed but with higher diameter;
- (-) each user along the distribution is not supplied at the same temperature and it is affected by the behaviour of the previous users;
- (-) it is important to design and to balance accurately the circuit by means of balancing valve or pumps;

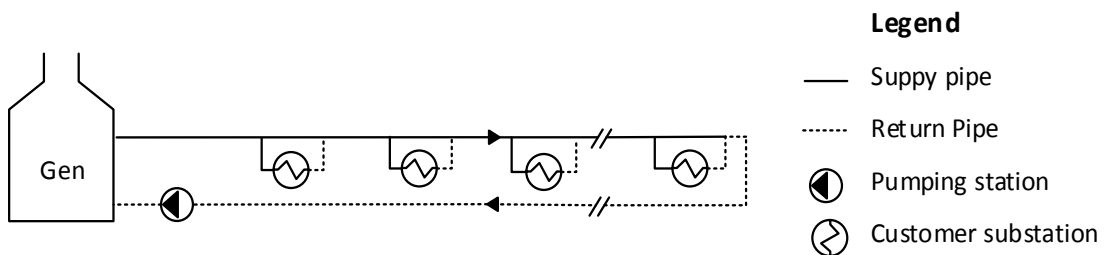

Figure 28: Simplified scheme of the one pipe distribution configuration.

8 Conclusions

In the present document we summarised the analysis made on the building stock typical of the EU countries with Mediterranean climate.

The analysis shows that apart for Italy and Spain that are largely dominated by multifamily houses, the other countries have a balanced share of single family homes and condominiums. Therefore the solutions for heating and cooling developed should take into consideration such diversity.

In general all countries feature an old building stock with low energy efficiency characteristics: space heating demand higher than 100 kWh/m²y and space cooling demand easily higher than 30 kWh/m²y. This is due on the one hand to the scarce performance of the buildings' envelope, on the other to the inadequate shading of the transparent surfaces at summertime.

Heating and cooling systems using heat pumps are clearly more effective than gas boiler based ones in terms of primary energy consumption. Therefore, this solutions should be promoted. However, their operation is not fully satisfactory during the coldest days of the year, with respect to the vast majority of the building stock.

Additionally to these systems, combinations of the heat pump with gas boilers have to be tackled, in order to evaluate the operation with regards to such buildings that cannot be fully served by means of low-enthalpy solutions.

One system that is particularly interesting is the one employing a water-to water heat pump. This is usually relatively expensive when connected to geothermal heat exchangers, due to the initial costs associated to the setup of the geothermal probes.

However, the same solution can be effectively be connected to low temperature district heating system, operating at temperatures close to the ground's (10-25 °C). In this case, an invertible cycle HP can be operated both in heating and cooling mode, at effectual and well controlled source side temperatures. Therefore the network can operate both as a heating and cooling one.

On the other hand, such low temperature district heating and cooling networks suffer of reduced thermal losses, and can integrated waste and renewable heat even when available at very low temperatures (> 30 °C).

Here we have reviewed shortly the DHC networks technology with a particular attention to the integration of available thermal energy sources and to the thermal storages. Based on the analysis of noteworthy case studies, we identified and rated three DHC network architectures that can be used to deliver low temperature heat from the source to the user. A detailed study must be carried out in order to understand what way of integrating and operating water-to-water heat pumps is the most effective with respect to such networks.

In the continuation of this work, different combinations will be rated and compared to a reference heating and cooling system based on a gas boiler and split units. Combinations of both the innovative and the traditional systems with solar thermal and PV technologies will be considered. In this document we have defined the performance figures that allow assessing systems' operation.

9 References

- [1] European Commission, Joint Research Centre, and European Technology Platform on Renewable Heating and Cooling (RHC-Platform), „2020-2030-2050, common vision for the renewable heating and cooling sector in Europe: European technology platform on renewable heating and cooling,“ EUR-OP, Luxembourg, 2011.
- [2] „Directive 2010/31/EU of the European Parliament and of the Council of 19 May 2010 on the energy performance of buildings (recast),“ Official Journal of the European Union, Brussels, 2010.
- [3] „Directive 2012/27/EU of the European Parliament and of the Council of 25 October 2012 on energy efficiency,“ Official Journal of the European Union, Brussels, 2012.
- [4] B. Rezaie and M. A. Rosen, „District heating and cooling: Review of technology and potential enhancements,“ *Appl. Energy*, Bd. 93, pp. 2-10, 2012.
- [5] International Energy Agency, „Linking Heat and Electricity Systems: Cogeneration and District Heating and Cooling Solutions for a Clean Energy Future,“ IEA, Paris, 2014.
- [6] Connolly D., Mathiesen B. V., Østergaard P. A., Möller B., Nielsen S., Lund H., Persson U., Werner S., Grözinger J., Boermans T., Bosquet M., Trier D., „Heat Roadmap Europe 2: Second Pre-Study for the EU27. Department of Development and Planning,“ Aalborg University, Aalborg, 2013.
- [7] DHC+ Technology Platform, „District heating & cooling: a vision towards 2020-2030-2050,“ Brussels, 2012.
- [8] „RESCUE project,“ [Online]. Available: www.rescue-project.eu.
- [9] D. Prando, A. Prada, F. Ochs, A. Gasparella, and M. Baratieri, „Analysis of the energy and economic impact of cost-optimal buildings refurbishment on district heating systems,“ *Science and Technology for the Built Environment*, Bd. 21, pp. 876-891, 2015.
- [10] Frederiksen S., Werner S., District Heating and Cooling, Lund: Studentlitteratur AB, 2013.
- [11] FLEXYNETS project, [Online]. Available: www.flexynets.eu.
- [12] A. Buonomano, F. Calise, and A. Palombo, „Buildings dynamic simulation: Water loop heat pump systems analysis for European climates,“ *Applied Energy*, Bd. 91, pp. 222-234, 2012.
- [13] Fischer D., Lindberg K.B., Mueller S., Wiemken E., and Wille-Hausmann B., „Potential for Balancing Wind and Solar Power using Heat Pump Heating and Cooling Systems,“ in *4th Solar Integration Workshop*, Berlin, 2014.
- [14] P.-A. Viquerat, Utilisation des réseaux d'eau lacustre profonde pour la climatisation et le chauffage des bâtiments; bilan énergétique et impacts environnementaux: Etude de cas: le projet GLN (Genève-Lac-Nations) à Genève, Geneva: University of Geneva, 2012.

- [15] Boyce F. M., Hamblin P. F., Danny Harvey L.D., Schertzer W. M., and Craig Mc Crimmon R., „Response of the Thermal Structure of Lake Ontario to Deep Cooling,“ *Journal of Great Lakes Research*, Bd. 19, pp. 603-616, 1993.
- [16] F. Ruesch, M. Rommel, and J. Scherer, „Pumping power prediction in low temperature district heating networks,“ in *roceedings of International Conference CISBAT 2015 Future Buildings and Districts Sustainability from Nano to Urban Scale*, Lausanne, 2015.
- [17] „Best Practice Book,“ InSun project, 2015.
- [18] Miedaner O., Pauschinger T., „Categories of solar district heating systems,“ Solar district heating project, 2012.
- [19] „Referenze Terziario CLIVET Spa,“ [Online]. Available: www.clivet.com.
- [20] Drijver B. and Willemsen A., „Groundwater as a heat source for geothermal heat pumps,“ in *International Summer School on Direct Application of Geothermal Energy*, International Geothermal Association, 2001.
- [21] Belotti G. and Tarantino P., „Il teleriscaldamento "freddo",“ COGEME SpA, Rovato, 2013.
- [22] S. F., „Sewage water: interesting heat source for heat pumps and chillers,“ Energy-engineer FH, Swiss Energy Agency for Infrastructure Plants, Zürich, 2009.
- [23] Cipolla S. S., Maglionico M., „Heat recovery from urban wastewater: analysis of the variability of flow rate and temperature in the sewer of Bologna, Italy,“ *Energy Procedia* , Bd. 45, p. 288 - 297, 2014.
- [24] Bettanini E., Brunello P., *Lezioni di impianti tecnici*, Padova: CLEUP, 1993.
- [25] Danish Energy Agency, „Technology Data for Energy Plants,“ Danish Energy Agency, Energinet.dk , 2014.
- [26] PlanEnergi, Danish Technological Institute, GEO, Green Energy, „Report concerning heat storage technologies and large heat pumps for use in the district heating system,“ PlanEnergi (in Danish), 2013.
- [27] Mangold, D. and Deschaintre, L., „): Mangold, D. and DeschainSolar Heating and Cooling Programme: Task 45 Large Systems: Seasonal thermal energy storage - Report on state of the art and necessary further R+D.,“ International Energy Agency, 2015.

(CIT Energy Management, 2011): CIT Energy Management AB (2011). SUNSTORE 4, WP 5: European Level Concept Study – Feasibility/Simulation Studies.

(Danish Energy Agency, 2014): Danish Energy Agency, Energinet.dk (2014). Technology Data for Energy Plants.

(Frederiksen, 2013): Frederiksen, S. and Werner, S. (2013). District Heating and Cooling. Studentlitteratur AB, Lund.

(Mangold, 2015): Mangold, D. and Deschaintre, L. (2015). Solar Heating and Cooling Programme: Task 45 Large Systems: Seasonal thermal energy storage – Report on state of the art and necessary further R+D. International Energy Agency.

(PlanEnergi, 2013): PlanEnergi, Danish Technological Institute, GEO, Green Energy (2013). Udredning vedrørende varmelagringsteknologier og store varmepumper til brug i fjernvarmesystemet. (In Danish; the title translates as: Report concerning heat storage technologies and large heat pumps for use in the district heating system).

(PlanEnergi, 2015): PlanEnergi, NIRAS, Danish Technological Institute, Marstal Fjernvarme, Dronninglund Fjernvarme, SOLITES (2015). SUNSTORE 3, Phase 2: Implementation - Final Report.