



Agenzia Nazionale per le Nuove Tecnologie,
l'Energia e lo Sviluppo Economico Sostenibile



Ministero dello Sviluppo Economico

RICERCA DI SISTEMA ELETTRICO

Pre-Test Analysis for an Experimental Campaign in the Upgraded HE-FUS3 Loop

P. Meloni, F.S. Nitti

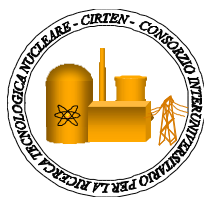

RELAZIONE TECNICA RELATIVA ALLA REALIZZAZIONE DI STRUMENTAZIONE PER LA
DETERMINAZIONE DELLE PROPRIETÀ TERMO-FISICHE DI UNA MISCELA DI SALI FUSI

P. Meloni ENEA, F.S. Nitti ENEA

Settembre 2010

Report Ricerca di Sistema Elettrico

Accordo di Programma Ministero dello Sviluppo Economico – ENEA

Area: Produzione e fonti energetiche

Tema: Nuovo Nucleare da Fissione

Responsabile Tema: Stefano Monti, ENEA

Titolo

Pre-Test Analysis for an Experimental Campaign in the Upgraded HE-FUS3 Loop

Descrittori
Tipologia del documento: **Rapporto Tecnico**
Collocazione contrattuale: Accordo di programma ENEA-MSE: tema di ricerca "Nuovo nucleare da fissione"

Argomenti trattati: **Generation IV reactors**
Reattori nucleari a gas
Sicurezza nucleare
Analisi incidentale
Sommario

On the basis of the results obtained in the 2009 experimental campaign conducted in the HE-FUS3 loop (CR BRASIMONE) within the framework of the first year of the AdP ENEA-MSE a new experimental campaign has been planned for the second year for the following reasons:

- the post-tests calculations performed with the RELAP5 code showed for some tests a lack of important information on the facility behaviour in transient conditions that would require the repetition of the tests with an upgraded instrumentation,
- new experimental tests conducted at higher pressure and mass flowrate considering previous and additional transient scenarios would allow to enlarge the experimental data base for the assessment of thermal-hydraulic codes used for HTR and VHTR design and safety analysis

As for the previous year the definition of the test matrix has been supported with pre-test calculations carried out with the T/H system code RELAP5. To this purpose the HE-FUS3 model assessed in the post-test activity has been used with minor modifications.

Note
Copia n.
In carico a:

2			NOME			
			FIRMA			
1			NOME			
			FIRMA			
0	EMISSIONE	15.9.2010	NOME	P. Meloni	M. Tarantino	S. Monti
			FIRMA			
REV.	DESCRIZIONE	DATA		REDAZIONE	CONVALIDA	APPROVAZIONE

 Ricerca Sistema Elettrico	Sigla di identificazione	Rev.	Distrib.	Pag.	di
	NNFISS – LP3 - 002	0	L	2	134

Table of Contents

1. Introduction

2. Upgrading of the HE-FUS3 facility

2.1 Present Status of the Facility

2.2 New Instrumentation Needs

2.3 Loop Modifications

3. Adjustment of the Numerical Model

3.1 RELAP5 Computer Code & Loop Nodalization

3.2 Modifications of the HE-FUS3 Model

4. Pre-test Calculations

4.1 Start-up by Steps

4.2 LOFA Transient

4.3 Transient of Power (TOP)

4.4 LOCA Transient

5. Conclusions

6. References

Appendix A: RELAP5 Input Deck for Steady State Conditions

Appendix B: RELAP5 Input Deck for LOFA

Appendix C: RELAP5 Input Deck for TOP

Appendix D: RELAP5 Input Deck for LOCA

 Ricerca Sistema Elettrico	Sigla di identificazione	Rev.	Distrib.	Pag.	di
	NNFISS – LP3 - 002	0	L	3	134

1. Introduction

HE-FUS 3 is a helium facility that was designed and constructed at ENEA CR Brasimone in mid 90's for the thermal-mechanical testing of prototypical module assemblies of the DEMO reactor [1]. Within the frame of the first year of the AdP ENEA-MSE SP an experimental campaign was carried out in 2009 [2] with the objective to provide a reliable experimental data base for the assessment of thermal-hydraulic codes used for HTR and VHTR design and safety analysis.

On the basis of the results obtained in the 2009 experimental campaign [3] a new series of tests has been planned for the second year for the following reasons:

- the post-tests calculations performed with the RELAP5 code showed for some tests a lack of important information on the facility behaviour in transient conditions that would require the repetition of the tests with an upgraded instrumentation,
- new experimental tests conducted at higher pressure and mass flowrate considering previous and additional transient scenarios would allow to enlarge the experimental data base for the assessment of thermal-hydraulic codes used for HTR and VHTR design and safety analysis.

As for the previous year the definition of the test matrix has been supported with pre-test calculations [4] carried out with the T/H system code RELAP5. To this purpose the HE-FUS3 model assessed in the post-test activity has been used with minor modifications.

The new experimental campaign will be devoted to characterize the loop at higher pressure and mass flowrate by means of a step-by-step start-up procedure. Then a series of three transients will be conducted on the facility including: Loss of Flow Accident (LOFA) driven by the compressor slow-down, Transient of Power (TOP) driven by an increase of the Test Section electrical power and Loss of Coolant Accident (LOCA) caused by the opening of a valve on the tank.

For the first two transients the pre-test calculation have addressed in particular to define the dynamic conditions of the loop to guarantee that safety limits of the HE-FUS3 loop were not reached. The third test has also requested to assess the suitability of the discharge line to be implemented in the facility.

In the appendixes A to D the RELAP5 input decks developed for the pre-test calculations and opportunely commented are reported.

2. Upgrading of the HE-FUS3 facility

2.1 Present Status of the Facility

The facility, constructed with the EU economic support of the European Fusion Technology Program in 1995 at ENEA Brasimone Center, was used for the thermal mechanical testing of prototypical module assemblies for European Helium Cooled Pebble Bed (HCPB) Blanket design to be tested on ITER reactor.

The facility, detailed described in a previous AdP ENEA-MSE report [4], supplies the helium flowrate at the requested conditions to a 7-pin Test Section by means its eight loop configuration showed in Fig. 2.1

The purpose of the eight-shaped closed loop arrangement is to separate two zones at different temperatures, the cold one including the compressor and the hot one the Test Section. An economizer, placed at the crossover point, recovers the gas enthalpy before recirculating the helium through the compressor. Thereby it has been possible to reduce both the need for external power to get the required temperature at the Test Section inlet and the cooler size to reduce the compressor inlet temperature to the level of its maximum continuative operating temperature. The present components allow the facility to achieve the performances reported in Tab. 2.1.

In order to support the testing of HCPB and Helium-Cooled Lithium Lead (HCLL) full scale Test Blanket Module (TBM) for ITER operation, the facility will be upgraded to achieve the higher performances also reported in Tab. 2.1. The first modification planned in the facility is the installation of a new compressor that is foreseen during 2010. Due to the uncertainty about the date in which the installation will be completed, the experimental program will be conducted with the old compressor that, in any case, will be available on a parallel line.

Parameter	Previous Value	Upgraded Value
Max Pressure (MPa)	10.5	10.5
Max Temperature (°C)	530	530
Inlet Compressor Max Temperature (°C)	100	100
Compressor Helium Flow Rate (kg/s)	0.05-0.35	0.27-1.4
Max Compressor Speed (rpm)	18000	-
Max Compressor Head (MPa)	0.5	0.9
Compressor Electrical Power (kVA)	136	190
Heaters Electrical Power (kW)	210	210
Economizer Thermal Power (kW)	564	1450
Air-Cooler Thermal Power (kW)	280	280
Helium Tank Capacity (m ³)	3	3

Tab. 2.1 – HE-FUS3 Present and Upgraded Performances

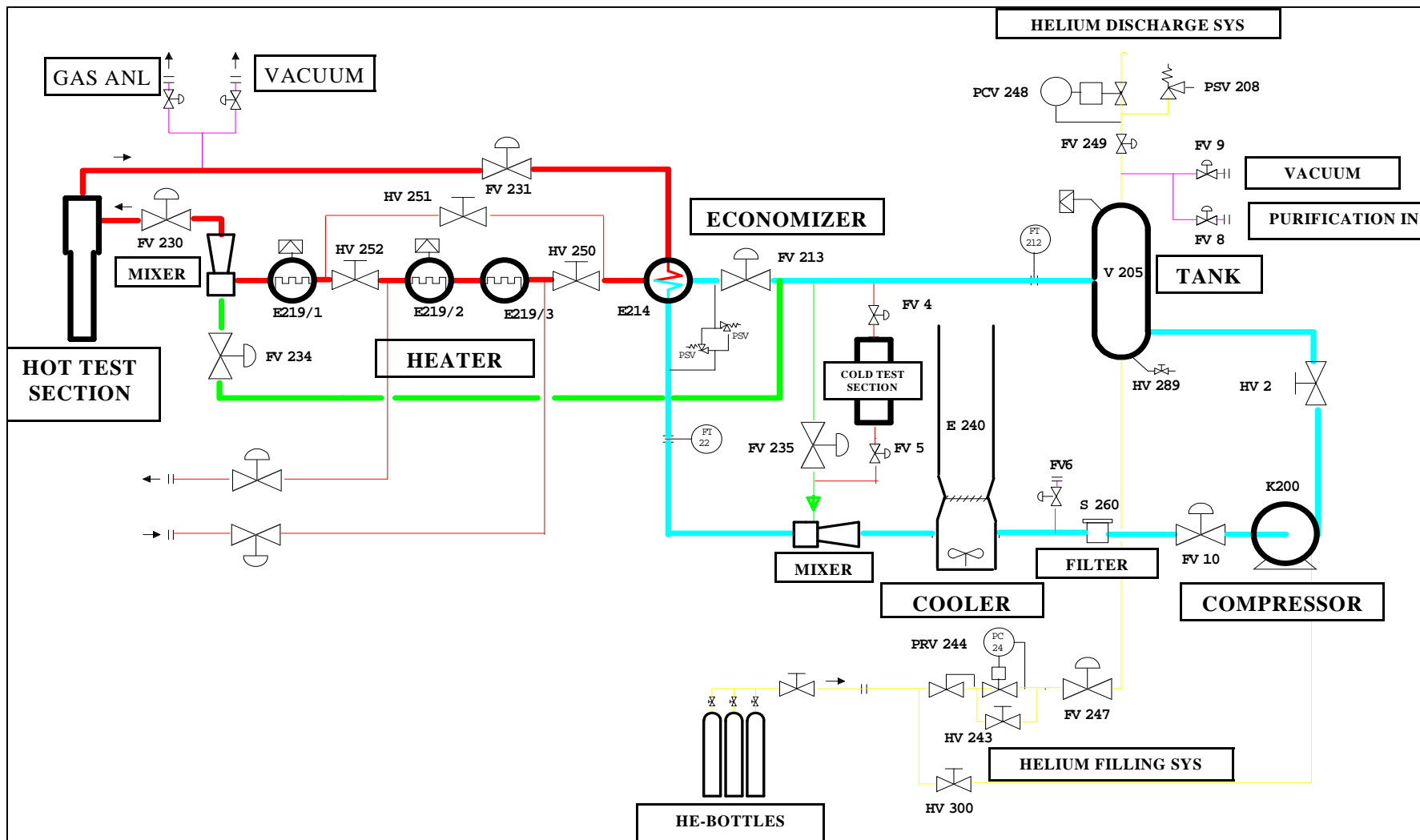



Fig. 2.1 – HE-FUS3 P&I

 Ricerca Sistema Elettrico	Sigla di identificazione	Rev.	Distrib.	Pag.	di
	NNFISS – LP3 - 002	0	L	6	134

2.2 New Instrumentation Needs

The instrumentation map of the facility is shown in Fig. 2.3. This paragraph is addressed to summarize the insufficiency of instrumentation highlighted by the experimental program and related post-test analysis performed during the first year of ENEA-MSE AdP [2], [3]. In the following the different problems meet and the possible solutions proposed are reported:

- Except for the thermocouples at the inlet and outlet of the Test Section, installed for the last year experimental campaign (TE101 and TE102, all the measurements of helium temperatures in the loop are influenced by the wall thermal inertia. This behaviour is shown both by thermocouples in the cockpit and in the ones directly exposed to the fluid and used for the regulation chains. The effect on the measurements although more evident in transient conditions is also present in steady state conditions, where using the wall temperature instead of the helium temperature in the thermal balance introduces an error in the calculation of the power exchanged in the economizer or dissipated outside the loop. In order to partially solve this problem it would be necessary to install four more thermocouples in the key positions to calculate the power exchanged in the economizer (TR217, TR216 e TR218) and the heat dissipated in the heaters zone (TR222).
- The parameters recorded during the transient tests performed in 2009 showed an inadequate frequency of acquisition of the experimental data. This is particular evident for the trend of parameters like pressure, mass flowrates and pressure drops. The optimum would be to have an acquisition system with the possibility to vary the frequency according to the dynamic of the transient, as in the new system installed on the 7-pin Test Section for the last year experimental program. In case it is not possible to change the acquisition frequency for all parameters, it is necessary to do that for the pressure measurements in order to allow the characterization of the loop depressurization in the LOCA transient. Moreover, the sensibility of the measurement should be increased (0.1 bar instead of the present value of 1 bar). This last considerations is applicable to all temperature measurements, where it is recommended to pass from a sensibility of 1 °C to 0.1 °C to better characterize the evolution of the loop temperatures in transient conditions.
- In the LOCA transient it is absolutely necessary to install a device for the measurement of the mass flowrate that is an essential information for the assessment of the system codes.
- During the previous experimental campaign, a few of thermocouples in the 7-pin TS have recorded values in disagreement with the other ones. These values have not been considered for the post-test analysis, anyway, in order to better understand the reason of that, it would be desirable to verify the exact position of the thermocouples within the bundle and their electrical connection. To this scope it should be considered the possibility to open the Test Section at the end of the new experimental campaign.
- In order to obtain a better characterization of the heat losses in term of distribution along the loop, some thermocouples should be positioned on the external of the insulation material in some components and lines: economizer, heaters zone, Test Sections and its connection line.

 Ricerca Sistema Elettrico	Sigla di identificazione NNFISS – LP3 - 002	Rev. 0	Distrib. L	Pag. di 7 134
--	---	------------------	----------------------	-------------------------

- At present the only measurement related to the by-pass mass flowrate through the valve ZT234 is the valve opening percentage. Due to the old and incomplete information on the valve characteristic this parameter has poor significance for the code validation. On this purpose it would be extremely useful to install a suitable device for the mass flowrate measurement in the by-pass line.

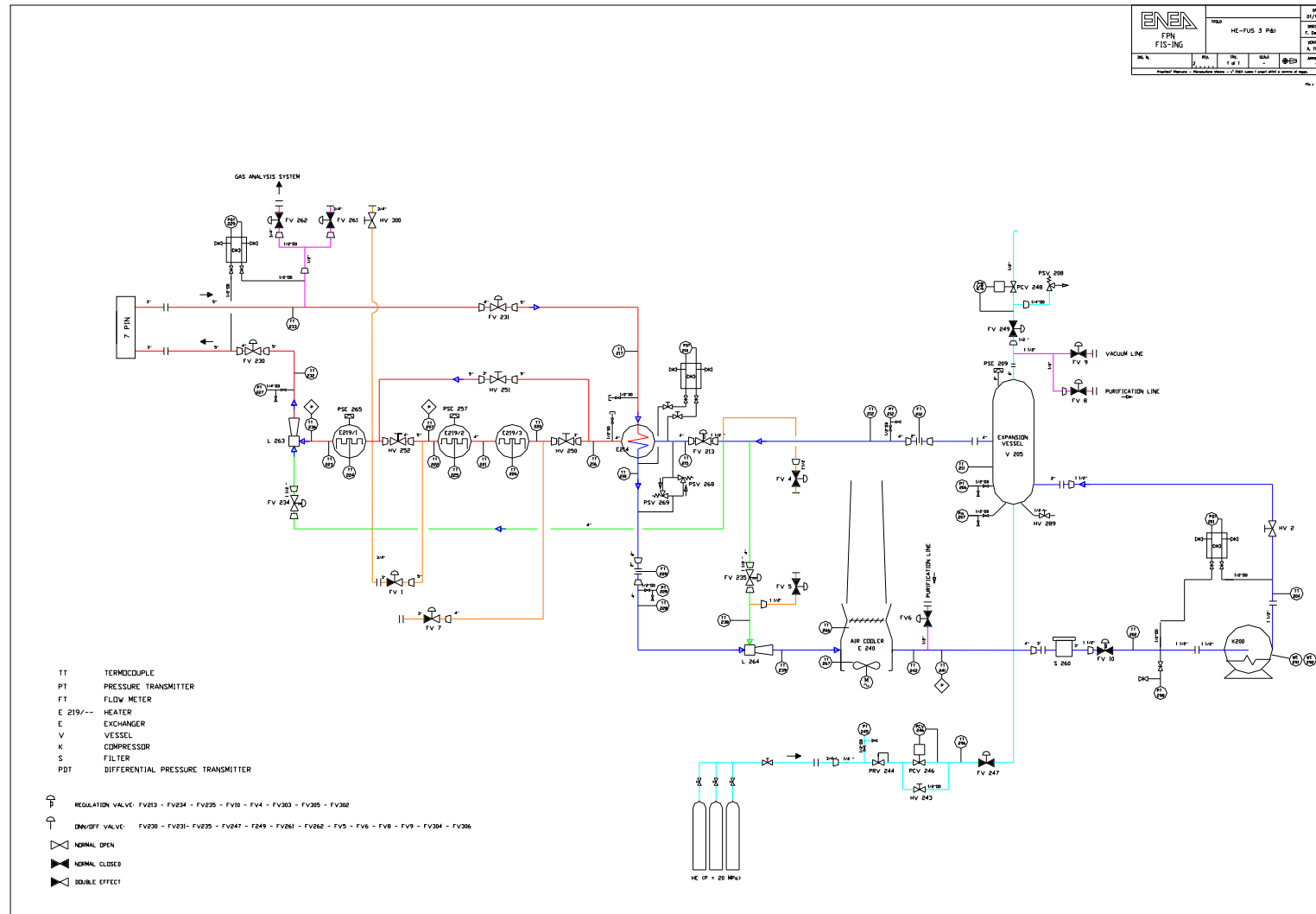

Fig. 2.3 – Instrumentation Map

2.3 Loop Modifications

As reported in the previous sub-paragraph the measurement of the break flowrate is necessary to acquire an exhaustive characterization of the LOCA transient. In Fig. 2.4 it is reported the scheme of a device to be installed on the loop to simulate the rupture by means of the 1”1/2 valve FV-9 on the top of the tank. This device will allow the measurement of the break mass flowrate by means a 2” vortex and its control through the valve at the end of the discharge piping.

The size of this valve (at present assumed 2”) will be carefully evaluate during the pre-test analysis in order to obtain a meaningful dynamic of the LOFA transient without exceeding the safety set-points of the loop. Thus avoiding the intervention of the protection system that would causing the electrical power shut-off and the interruption of the thermal transient.

As largely presented in the previous paragraph, further modifications requested in the loop concern essentially the need of new instrumentation. Since they do not imply an effect on the thermal-hydraulic behaviour of the loop, they will be defined also in accordance with the pre-test results presented in this report.

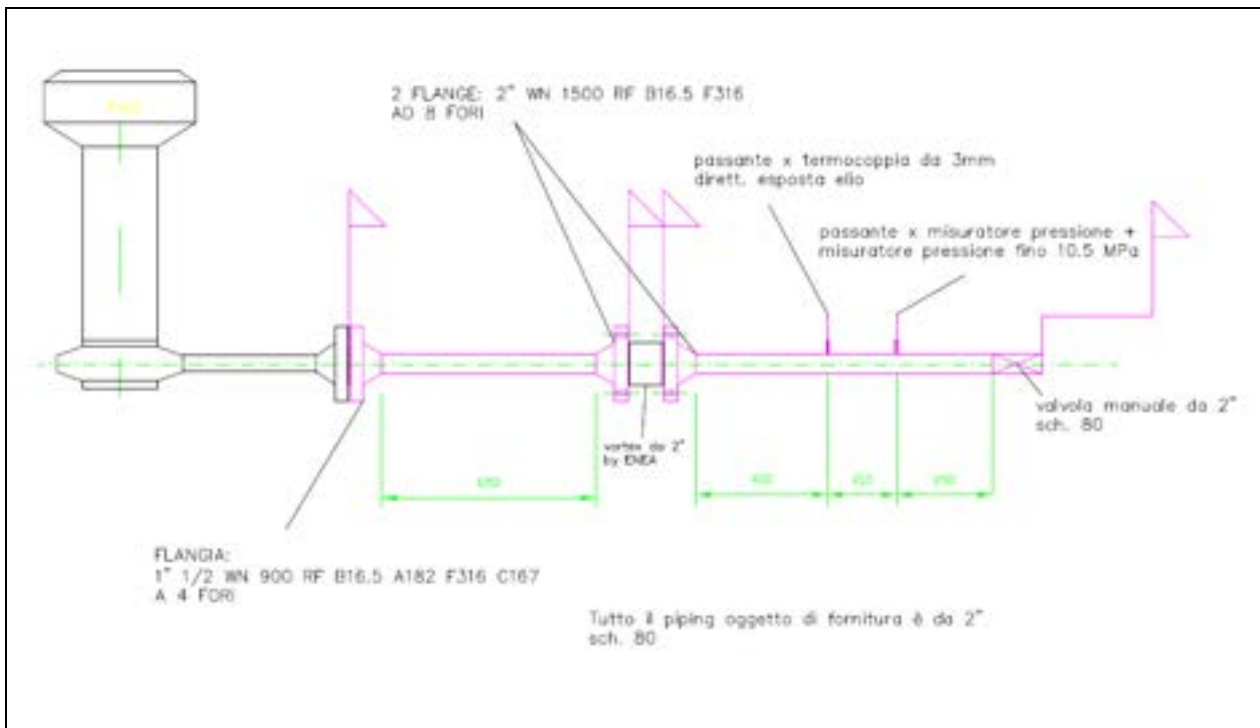



Fig. 2.4 - Test Section Thermocouples Location

 Ricerca Sistema Elettrico	Sigla di identificazione	Rev.	Distrib.	Pag.	di
	NNFISS – LP3 - 002	0	L	10	134

3. Adjustment of the Numerical Model

3.1 RELAP5 Computer Code & Loop Nodalization

As in the previous analyses, performed during the first year of the AdP ENEA-MSE, the latest Mod 3.3 version of Relap5 is the reference computer code used for the simulation of the thermal-hydraulic behaviour of the HE-FUS3. It is worth to remind that RELAP5 is a universally known computer program, developed by US NRC for the analysis of all transient and postulated accidents in LWR systems, including both large and small-break Loss-Of-Coolant Accidents (LOCAs) as well as the full range of operational transients.

The Relap5/Mod3.3 program [5] is based on a non-homogeneous and non-equilibrium model for the two-phase system that is solved by a fast, partially implicit numerical scheme to permit economical calculation of system transients. The code includes many generic component models from which general systems can be simulated. The component models include pumps, valves, and pipes, heat releasing or absorbing structures, reactor point kinetics, electric heaters, jet pumps, turbines, separators, accumulators, and control system components. In addition, special process models are included for effects such as form loss, flow at an abrupt area change, branching, choked flow, boron tracking, and non condensable gas transport.

Although several applications to gas cooled reactors and systems were carried out in the past [6], no specific components or models have been implemented in the code so far. RELAP5 has the capability to represent a wide variety of working fluids by means of a generalized equation of state. Taking advantage of this characteristic ENEA has developed a RELAP5 MOD3.3 version capable to treat helium as a coolant. As the functional verification of this version is still in progress, the standard approach to describe helium as a pure incondensable gas has adopted for the HE-FUS3 calculations.

The main rules adopted for the development of the numerical model of the loop where the following:

- the whole main loop should be modelled in order to assess the capability to simulate the dynamic behaviour of the loop
- explicit models were used for the Economizer and Test Section to allow the verification of the heat transfer modelling in these components
- a compressor model able to adapt to the different loop conditions was adopted
- due to their great importance on the loop temperatures in transient condition the thermal inertia of the structures and the heat losses to the environment were modelled in detail

The loop model for RELAP5 calculation (Fig.3.1), initially built in the nineties [7] and upgraded for the recent analyses [4], has requested an updating in order to describe in detail the discharge line reported in figure 2.4. Moreover some slight modifications have concerned the modelling of Economizer and Compressor, two of the most important components of the loop.

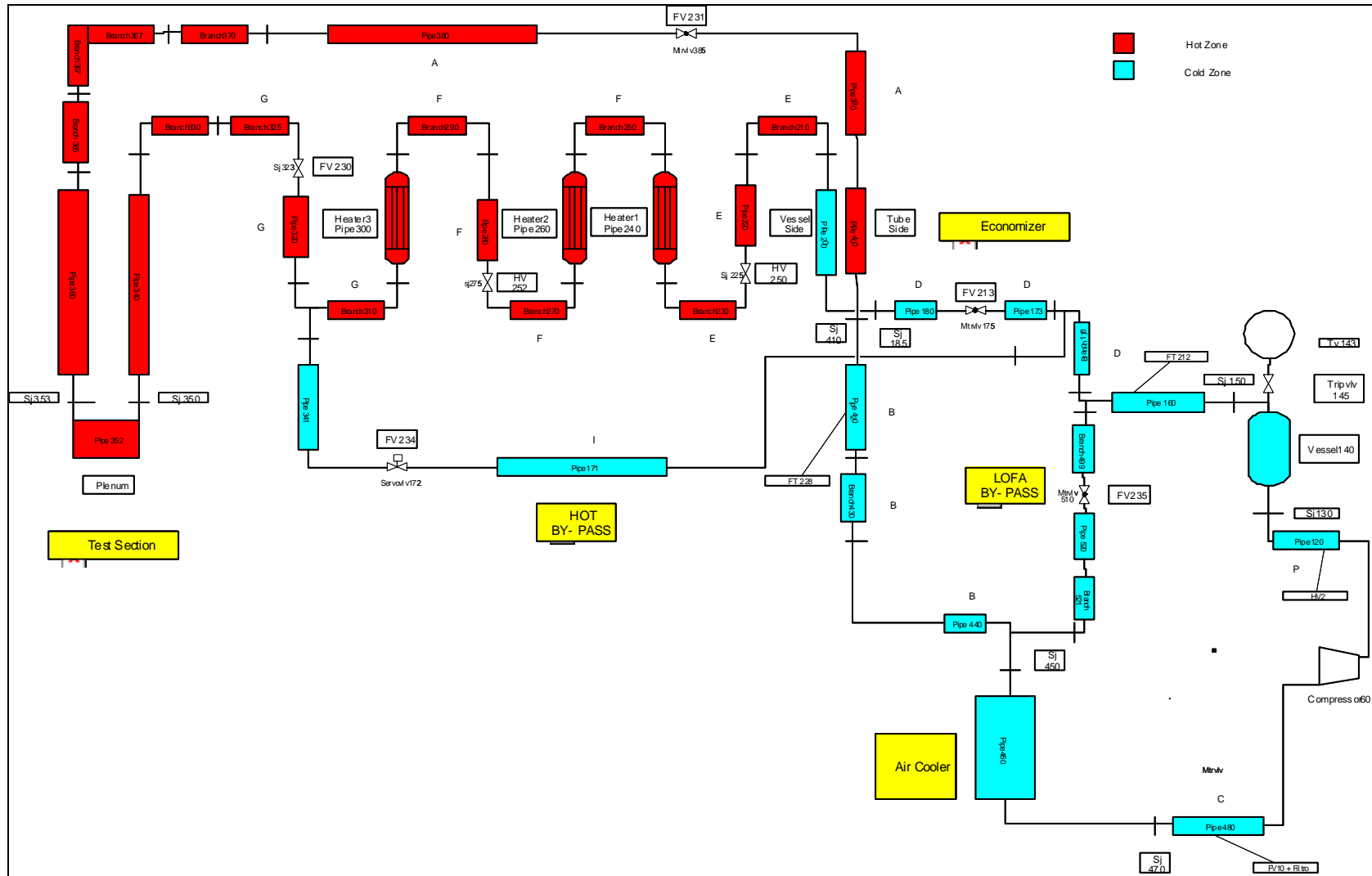



Fig. 3.1 – RELAP5 Nodalization Scheme of HE-FUS3

 Ricerca Sistema Elettrico	Sigla di identificazione	Rev.	Distrib.	Pag.	di
	NNFISS – LP3 - 002	0	L	12	134

3.2 Modifications of the HE-FUS3 Model

A detailed description of the different models adopted for the relevant components is provided in previous reports. In particular we recommend to refer to [4] for a concise description useful to better understand the RELAP5 simulations reported in the next chapters. In this paragraph only the modifications performed for the present pre-test activity are reported.

Discharge Line

The geometry of the line from the expansion tank, where is located the manual valve simulating the break, to the safety manual valve is described in detail. The size of the manual valve has to be determined by means of parametric calculations in order to reduce the break flowrate as the size of the automatic valve (1" 1/2) seems too large and it could cause a too fast depressurization of the loop.

The control valve has been modelled by using Relap5 motor valve component. For these component the requested Flow Coefficient (Cv) vs. percent Stroke curve has been provided starting from the Cv data supplied by the manufacturer (Fig. 3.2) and taking into account a combined pressure recovery factor and piping geometry factor of valve with attached fittings by means a multiplicative factor: $F_{LP} = 0.8$. The opening/closure time of the valve in the calculations has been considered of 3 s.

Compressor

The prototypical compressor is still simulated by means of the RELAP5 standard rotating pump component taking into account the gas heating. The interaction of the pump and the fluid is described by means of homologous curves that correlate pump head, torque and the volumetric flow, using dimensionless quantities. For a given rotation speed the dynamical dimensionless characteristics for head and torque have been built using the experimental compressor characterization tests carried out in 1988 (Fig 3.3).

Respect to the previous analyses the model has been considerably simplified in term of helium flow path. In fact, the compressor cooling system, which was previously simulated by means of a by-pass flow rate properly cooled to simulate the heat removed by a two stage water heat exchanger, is not described any more. The compressor is now considered as a black box that operates on the loop mass flowrate using the characterization tests to correlate rotation speed, pressure head, volumetric flow rate, helium inlet and outlet temperature (Figs 3.4 and 3.5).

Economizer

The Economizer is still simulated by means of two pipes representing the shell side and the tube side, and thermally coupled through the pipe wall heat structure. A previous tuning performed to obtain design performance in term of heat transfer capability and pressure drop has been repeated to improve heat transfer performance at different flow conditions. The inadequacy of the Dittus-Boelter correlation (standard RELAP5 correlation for convective heat transfer) for the shell side was highlighted in the past. In fact, in order to take into account the increase of thermal exchange performance due to the presence of diaphragms and consequent helium cross-flow (Fig 3.6) an artificially decreased heating diameter was

introduced in the model. The value of this diameter was chosen as a compromise to better reproduce the different flow conditions.

For the present calculation the model of the Economizer has been modified to better evaluate the convective heat transfer in the shell at the different flow conditions. The flow area, the heating diameter and the flow path has been imposed considering cross-flow of the cold helium caused by the presence of the diaphragms. The reduction of flow area causes an increase of the helium velocity with consequent improvement of the thermal exchange performance in good agreement with the available experimental data.

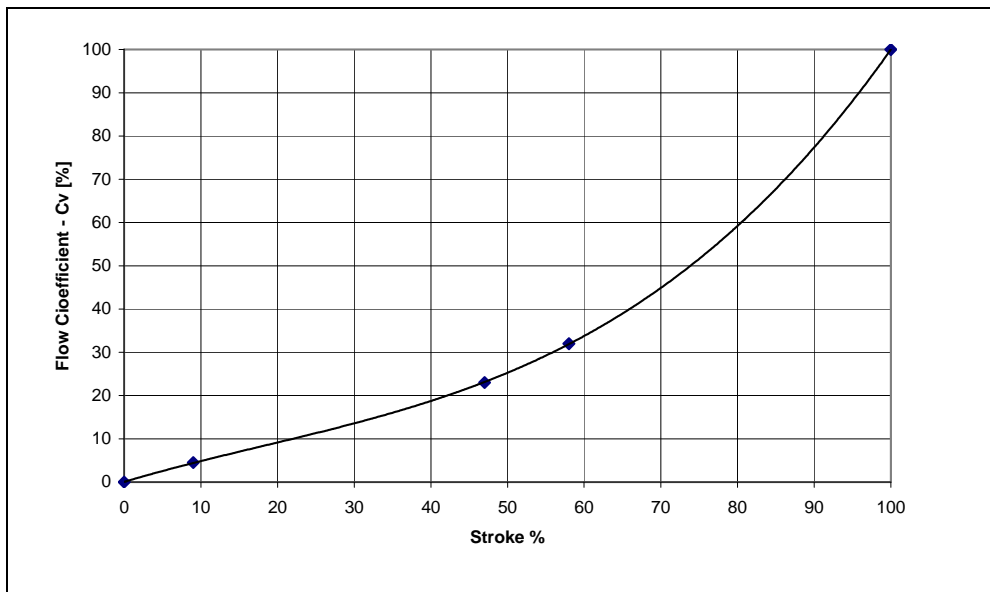

Fig. 3.2 – Characteristic of the Regulation Valves

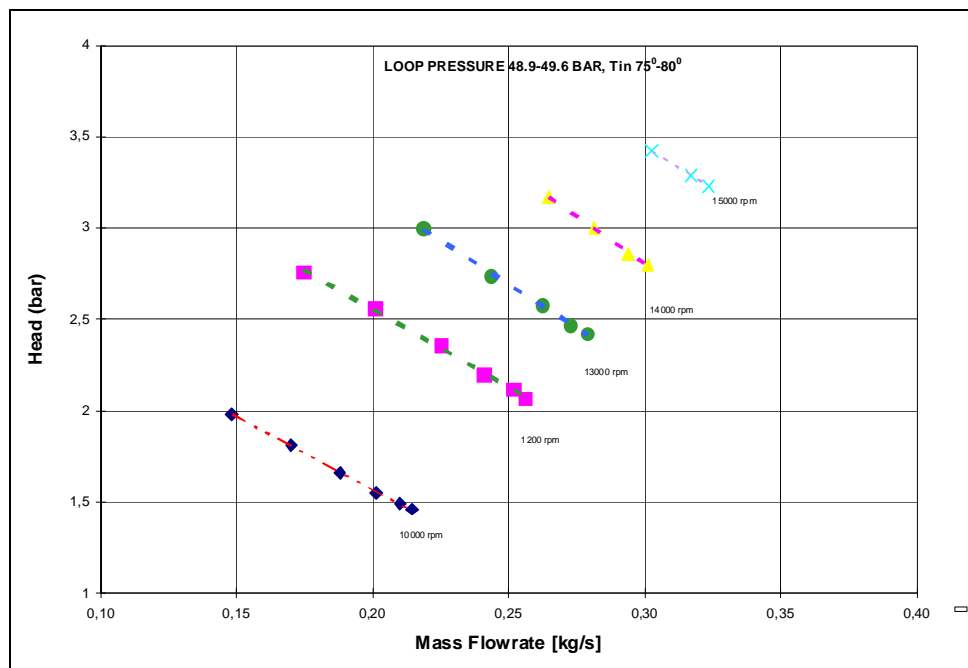
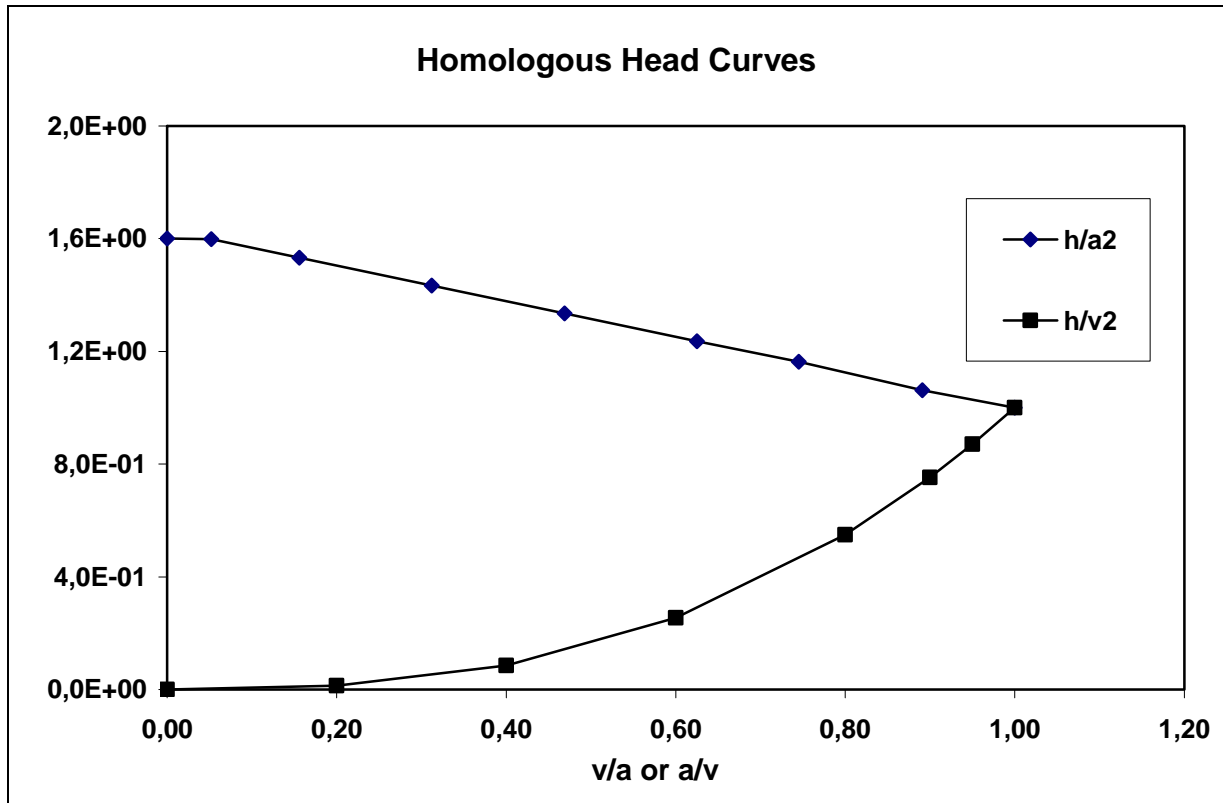
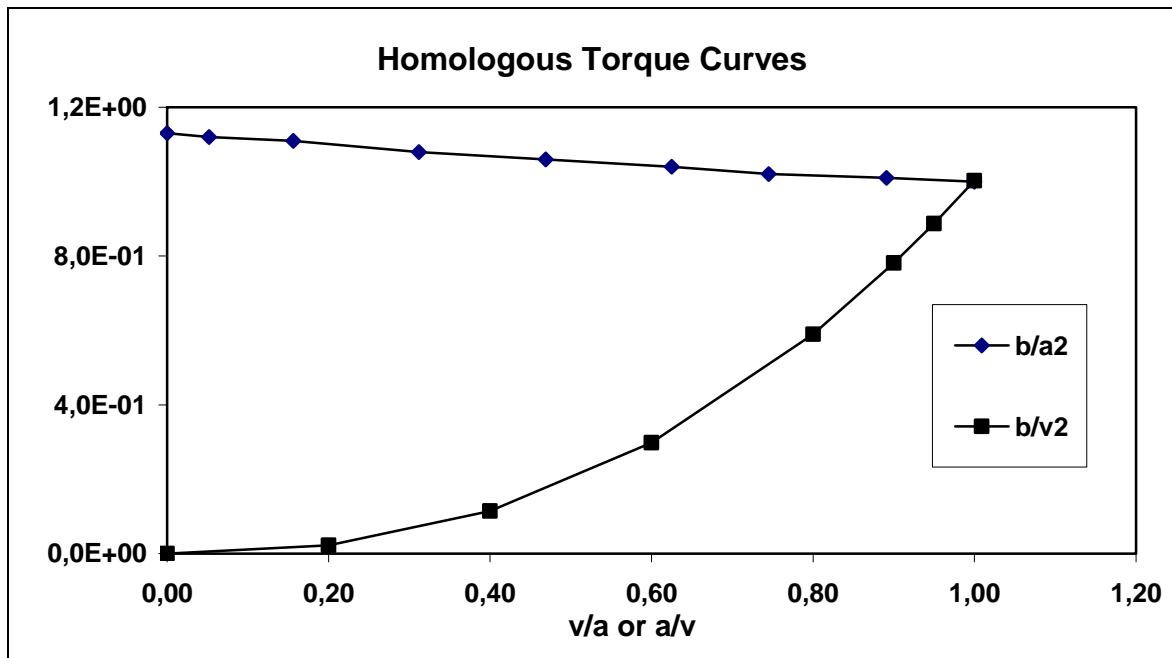



Fig. 3.3 – Compressor Characterization Curves



. 3.4 – RELAP Homologous Head Curve



3.5 – RELAP Homologous Torque Curve

 Ricerca Sistema Elettrico	Sigla di identificazione	Rev.	Distrib.	Pag.	di
	NNFISS – LP3 - 002	0	L	16	134

4. Pre-test Calculations

The new experimental program to be performed on the He-FUS3 facility is designed taking into account the results of the experimental and numerical activities carried out last year:

- the post-tests calculations performed with the RELAP5 code showed for some tests a lack of important information on the facility behaviour, in particular for the LOCA transients, that require the repetition of the tests with an upgraded instrumentation
- an exhaustive assessment of thermal-hydraulic codes used for HTR and VHTR design and safety analysis requires to enlarge the experimental data base considering higher pressures and mass flowrates and additional transient scenarios

In order to match these objectives the new experimental program will be composed by a series of steady states at 50 bar pressure to reach the reference conditions for the transients by steps, a Loss of Flow Accident (LOFA) driven by the compressor slow-down, a Transient of Power (TOP) driven by an increase of the Test Section electrical power and a Loss of Coolant Accident (LOCA) caused by the opening of a valve on the expansion tank.

4.1 Start-up by steps

A start-up procedure by steps is investigated in this pre-test analysis in order to collect data at different steady state conditions for the characterization of the heat losses in the hot zone of the loop and of the thermal exchange performance in the economizer at a higher pressure respect to the previous experimental data. The loop pressure is fixed at 50 bar and, in order to have more flexibility on the heating up dynamics, only TS electrical power is considered as heat source in the pre-test calculations.

In the Table 4.1 are reported the relevant initial and boundary conditions for the start-up steps. A 3-step increase of supplied power combined with a 2-step increase of compressor speed allow defining 4 different steady states characterized by different temperature distributions in the loop hot zone and different mass flowrates in the economizer. For each step the loop will take about 50000 s to reach steady state conditions (temperature variations less that 1 °C for hour) as showed in previous analyses [4]. In order to accelerate the RELAP5 calculations the thermal capacities of the loop materials have been decreased by a factor 1000 in the model. In this way after only 500 seconds the loop temperature is already stabilized. Of course, this assumption has been made only in calculations where the interest is not to simulate the response of the system to accidental events as in the following transient calculations, but just to reproduce the different steady state conditions that will be recorded during the start-up.

In Fig. 4.1 are described the variations of supplied power and compressor speed to get the different steps. The main loop parameters calculated are reported in Figs. 4.2 to 4.9. From Figs. 4.2 to 4.6, in particular, is shown how the loop temperatures stabilize at 4 different levels during the start-up. In Fig.4.3 it can be noticed that the temperature regulation at the inlet of the test section is always active only and the by-pass valve opens (Fig. 4.8) to limit this temperature to 300 °C. Finally, in Fig. 4.10 is showed the total pressure drop in the loop and in the test section that follow both the mass flowrate and slightly the temperature increase.

Steady state	Tank Pressure	Test Section power	Compressor Speed	Loop Mass Flowrate	Max Helium Temperature
	bar	kW	rpm	Kg/s	°C
First step start-up	50	90	10000	0.168	398
Second step start-up	50	90	13500	0.218	375
Third step start-up	50	120	13500	0.222	399
Forth step start-up	50	150	13500	0.225	424

Table 4.1 – Initial and boundary conditions for the start-up steps

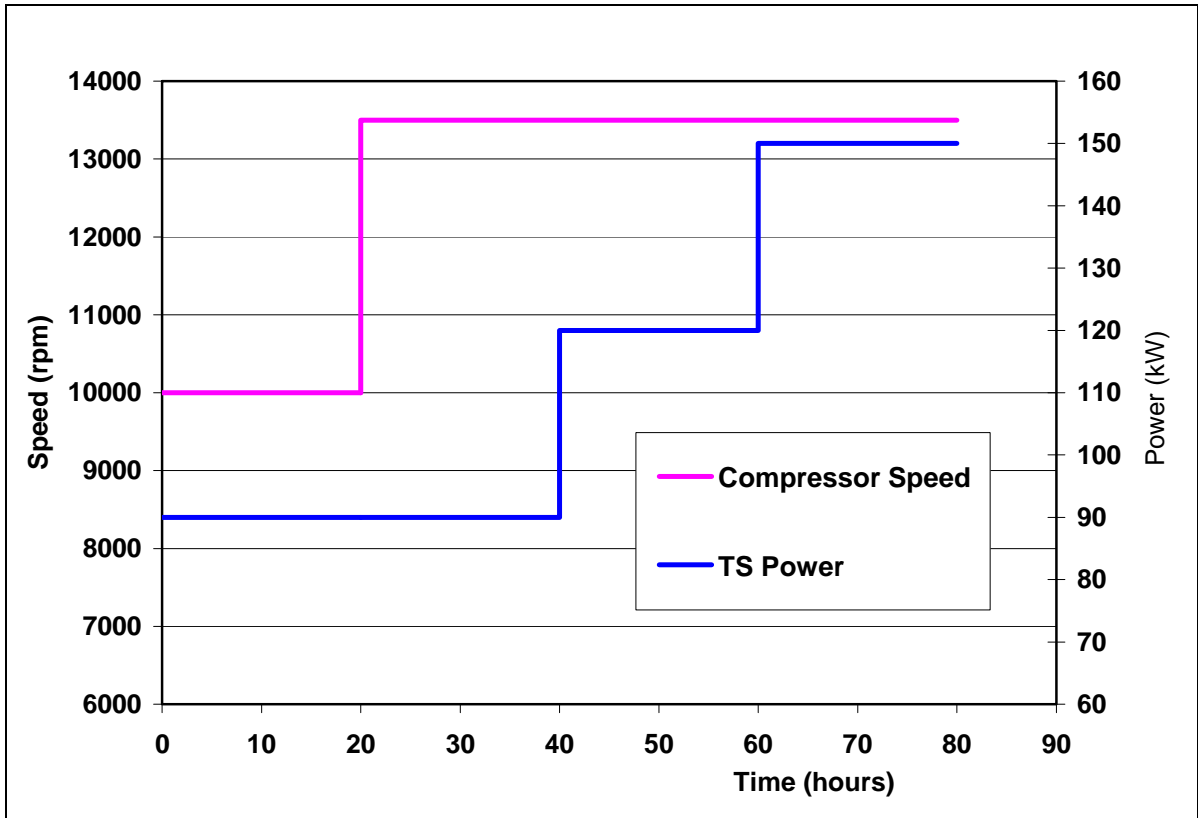

Fig. 4.1 – Compressor Speed and TS Power

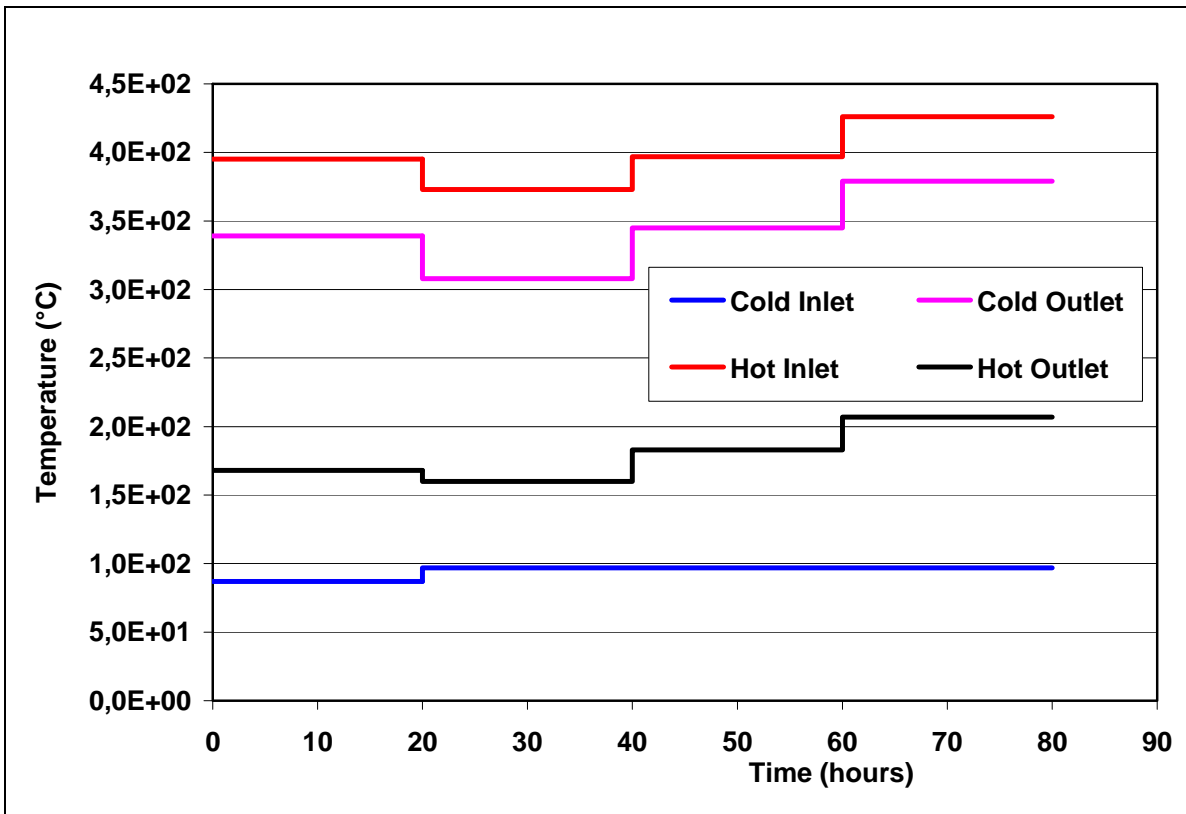

Fig. 4.2 – Inlet and Outlet Economizer Temperatures

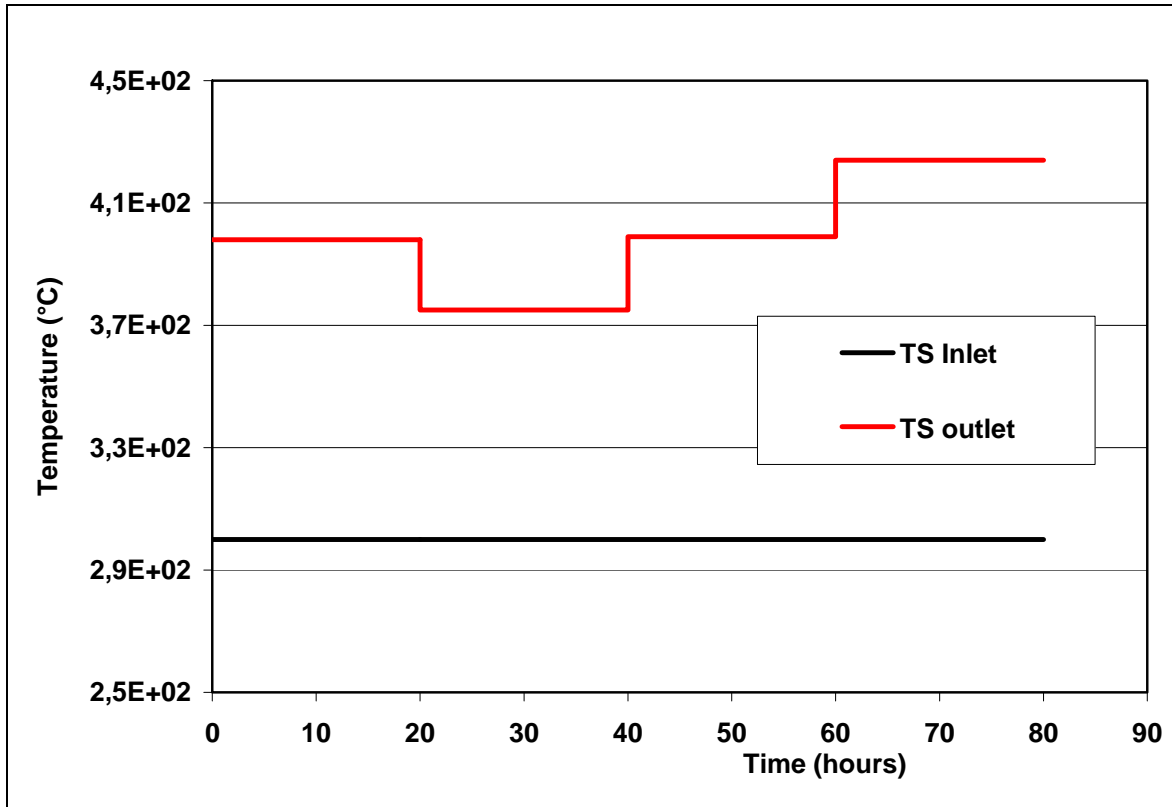

Fig. 4.3 – Inlet and Outlet TS Temperatures

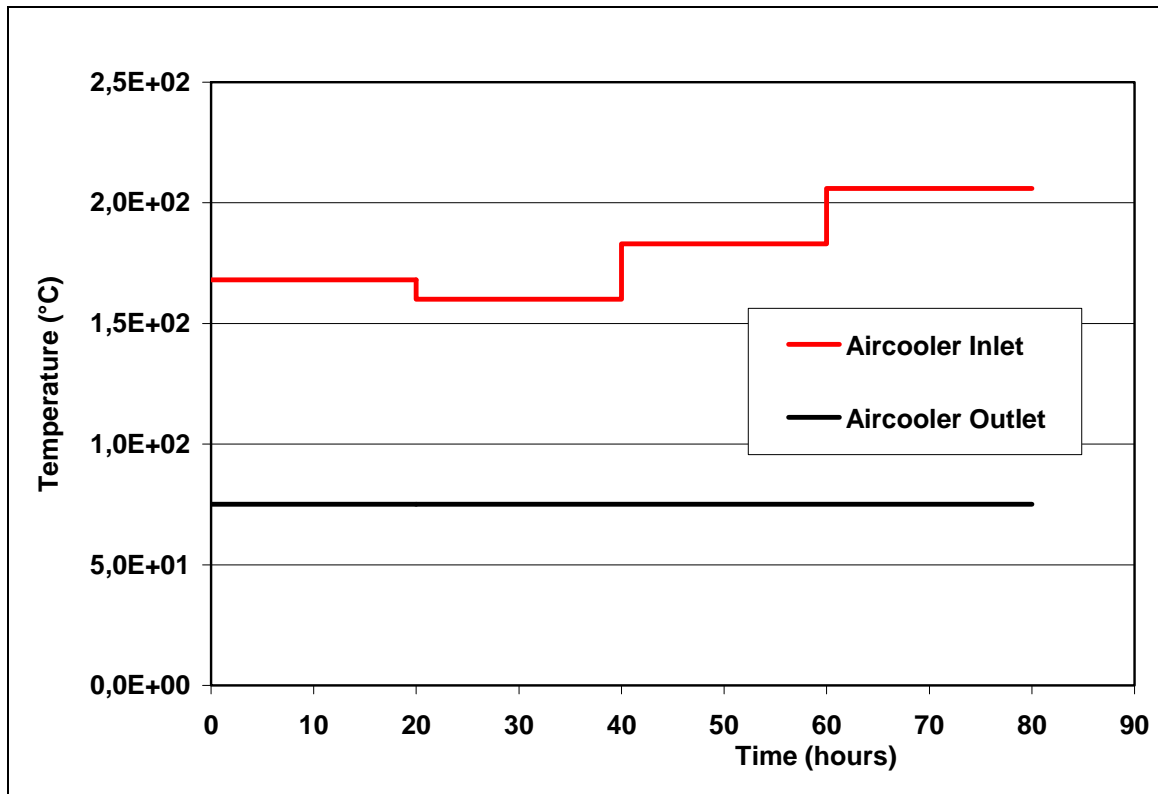

Fig. 4.4 – Inlet and Outlet Air Cooler Temperatures

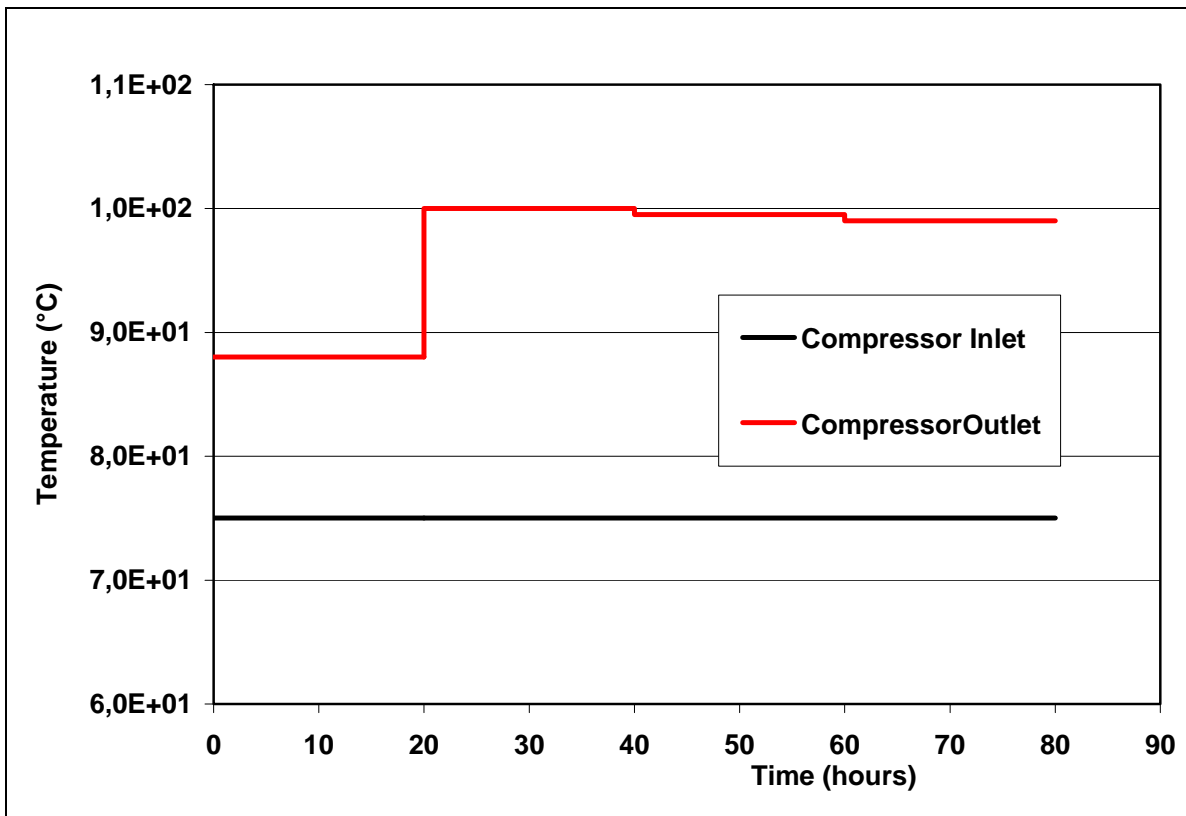

Fig. 4.5 – Inlet and Outlet Compressor Temperatures

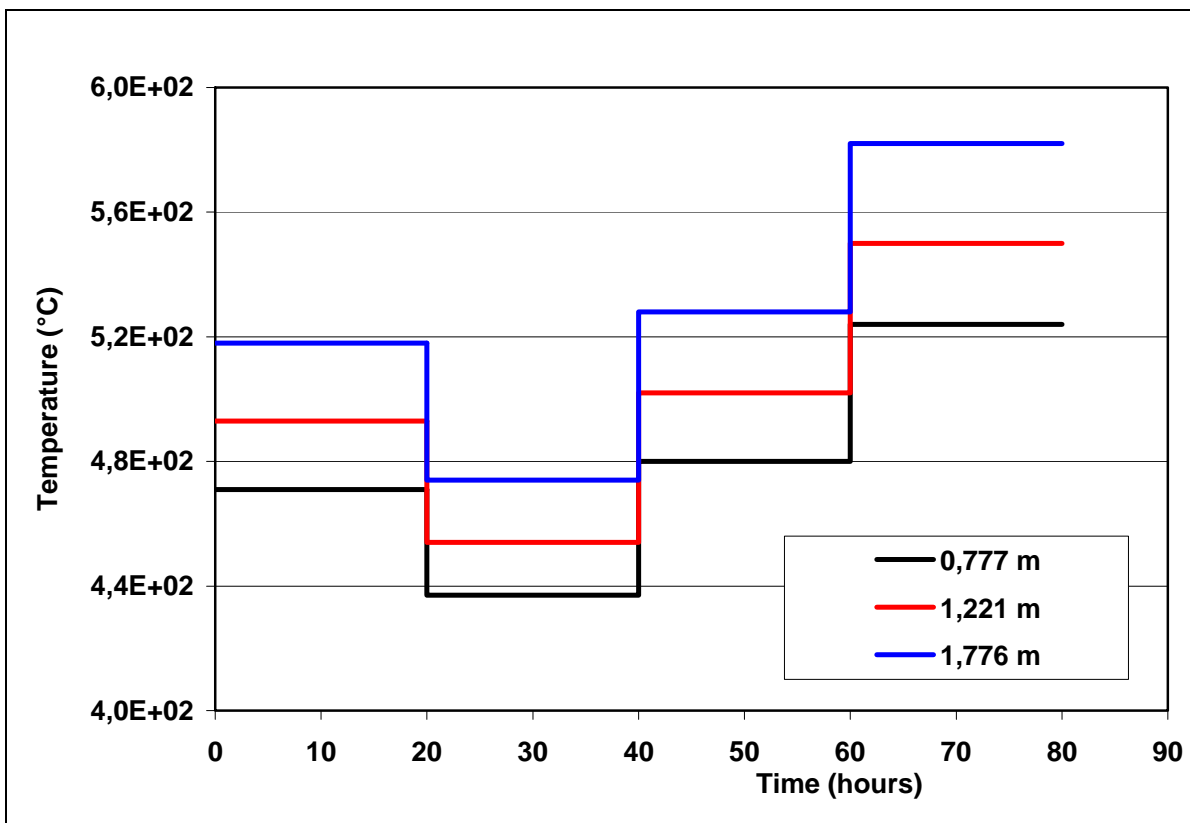

Fig. 4.6 – Pin temperatures at 0.25 m and at 1,75 m

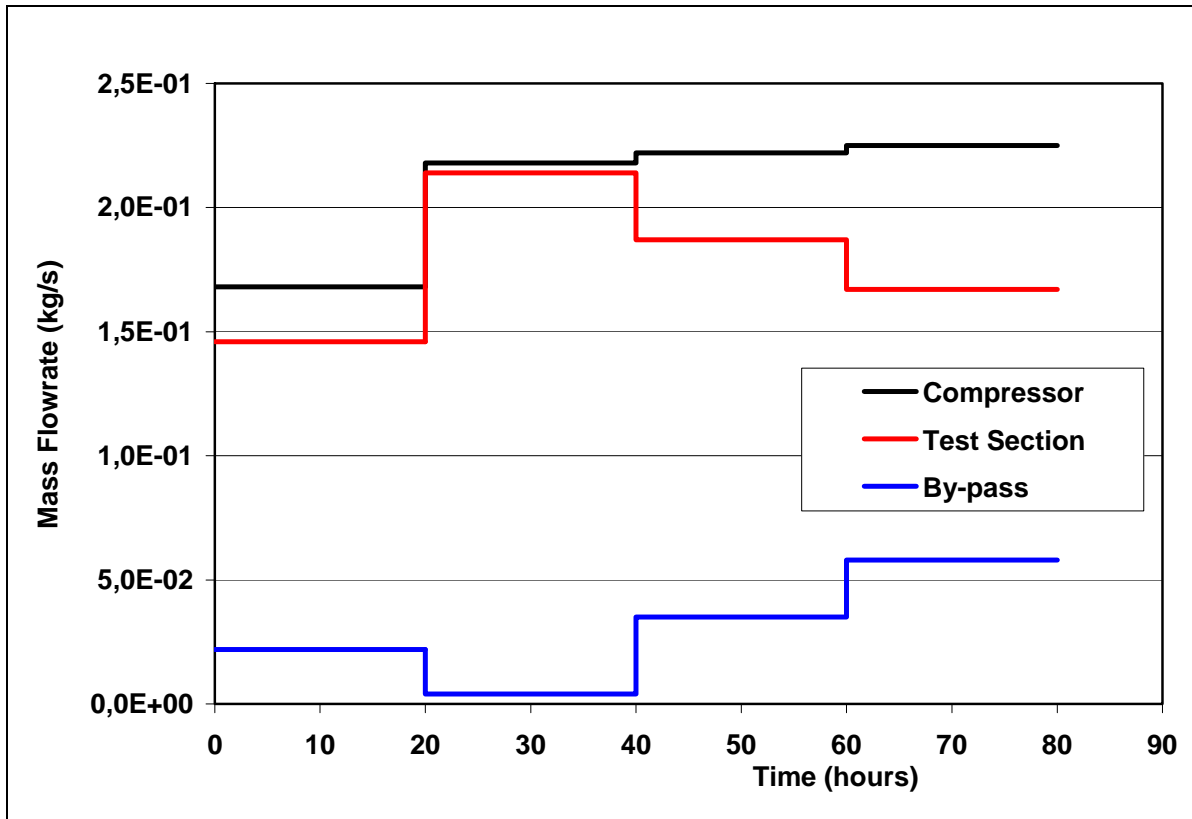

Fig. 4.7 – Loop Mass Flowrates

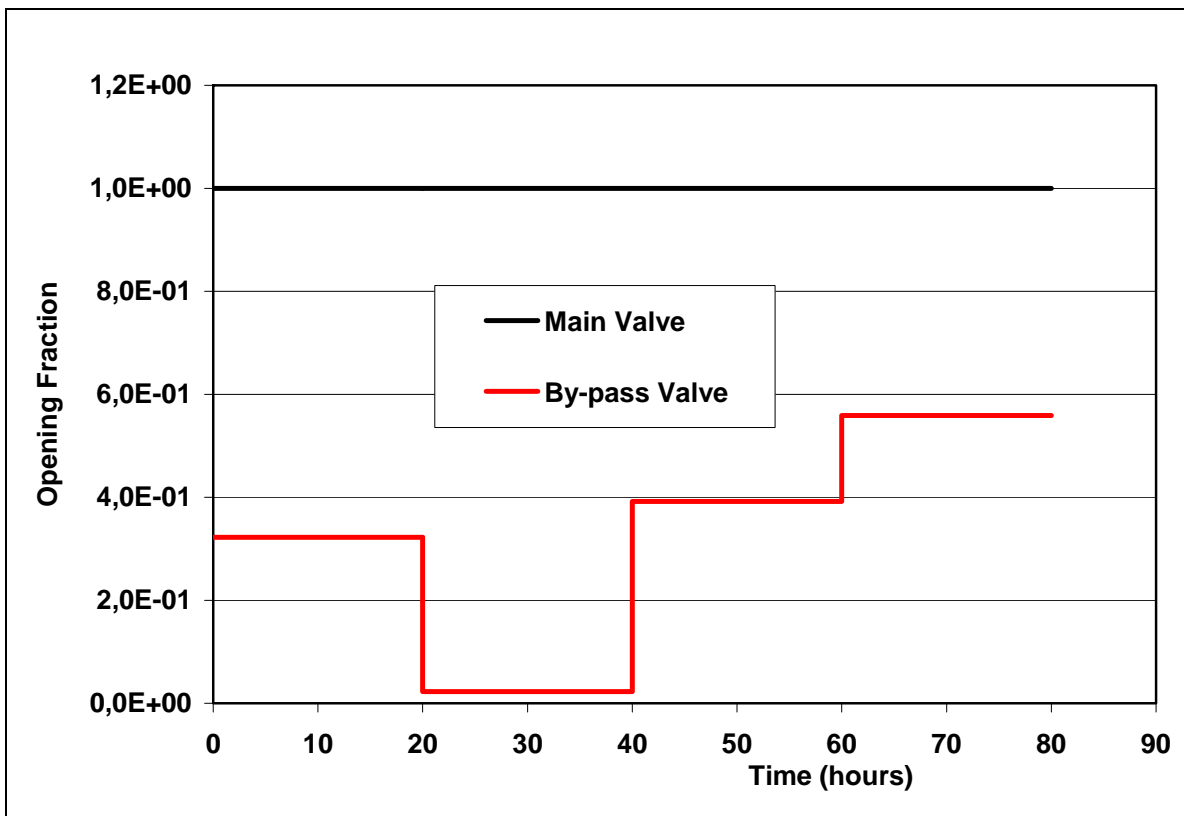

Fig.4.8 – Main and Bypass Valve Opening

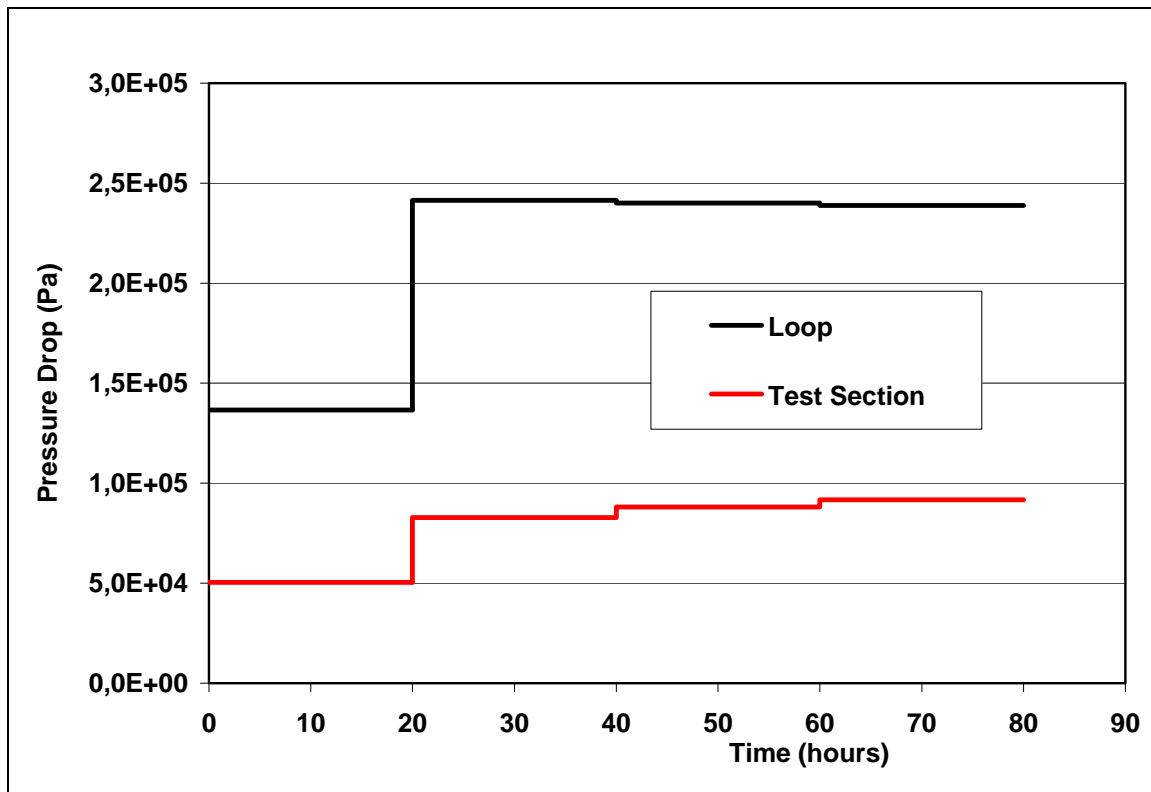

Fig.4.9 – Loop and Test Section Pressure Drops

4.2 LOFA Transient

A transient test characterized by a relevant reduction of the mass flowrate through the Test Section has been carried out by means of the compressor speed reduction. This test was intended to be representative of partial LOFA transients as those resulting from compressor coast-down events. In order to investigate the dynamic effect of the loop at high temperature the power supplied at the Test Section is maintained at initial value.

The main point investigated with the pre-test calculation lasting 2000 seconds have been the maximum helium and pin cladding temperatures reached during the transient in order to verify that the design limits for the loop and for the pin cladding are not attained. The results of the calculation reported in Figs. 4.10 to 4.20 show that the margin respect to these limits is sufficient also taking into account the conservative assumptions made in the calculation model.

The LOFA scenario, which starts from the steady state conditions attained at the conclusion of the start-up transient, has been simulated by means of a reduction of the compressor speed from 13500 rpm to 8500 rpm in 50 s. The initial and boundary conditions of the transient are reported in Table 4.2.

Figure 4.10 shows the reduction of the TS mass flowrate following the reduction of the compressor speed, which decreases from 0,225 kg/s to 0,14 kg/s. Due to this decrease the temperatures increase in the hot part of the loop. The maximum helium temperature that is localized at the outlet of the Test Section reaches 500 °C (Fig. 4.13) that is a sufficient margin respect to the limit of 530° C, and sufficient is the margin of the pin cladding temperature, 727 °C against the limit of 800 °C (Fig. 4.16).

After the 2000 sec transient calculated the loop temperature is not still stabilized due to the thermal inertia of the loop structures as it is shown by temperature trends in the hot part of the loop reported in Figs. 11 and 12. Also the bypass valve FV234 in Fig. 4.19, which is opening to maintain the temperature at TS inlet equal to 300 °C following the increase of temperatures, has not reached the stabilize value yet. As previously reported the loop temperature needs about 50000 s to be completely stabilized, however the loop dynamic behaviour is sufficiently characterized by 2000 seconds of transient here simulated.

Initial and Boundary Conditions	Value	Time (s)
Initial Pressure (bar)	50.	0.
TS Electrical Power (kW)	150.	0.
Initial Compressor Speed (rpm)	13500.	0.
Compressor speed start decreasing (rpm)	13500.	200.
Compressor speed stop decreasing (rpm)	8500.	250.
TS Helium Inlet Temperature (°C)	300.	All transient
Air Cooler Helium Outlet Temperature (°C)	75.	All transient
Valve F213 % Opening	100.	All transient

Table 4.2 – Initial and boundary conditions for the LOFA through compressor speed reduction

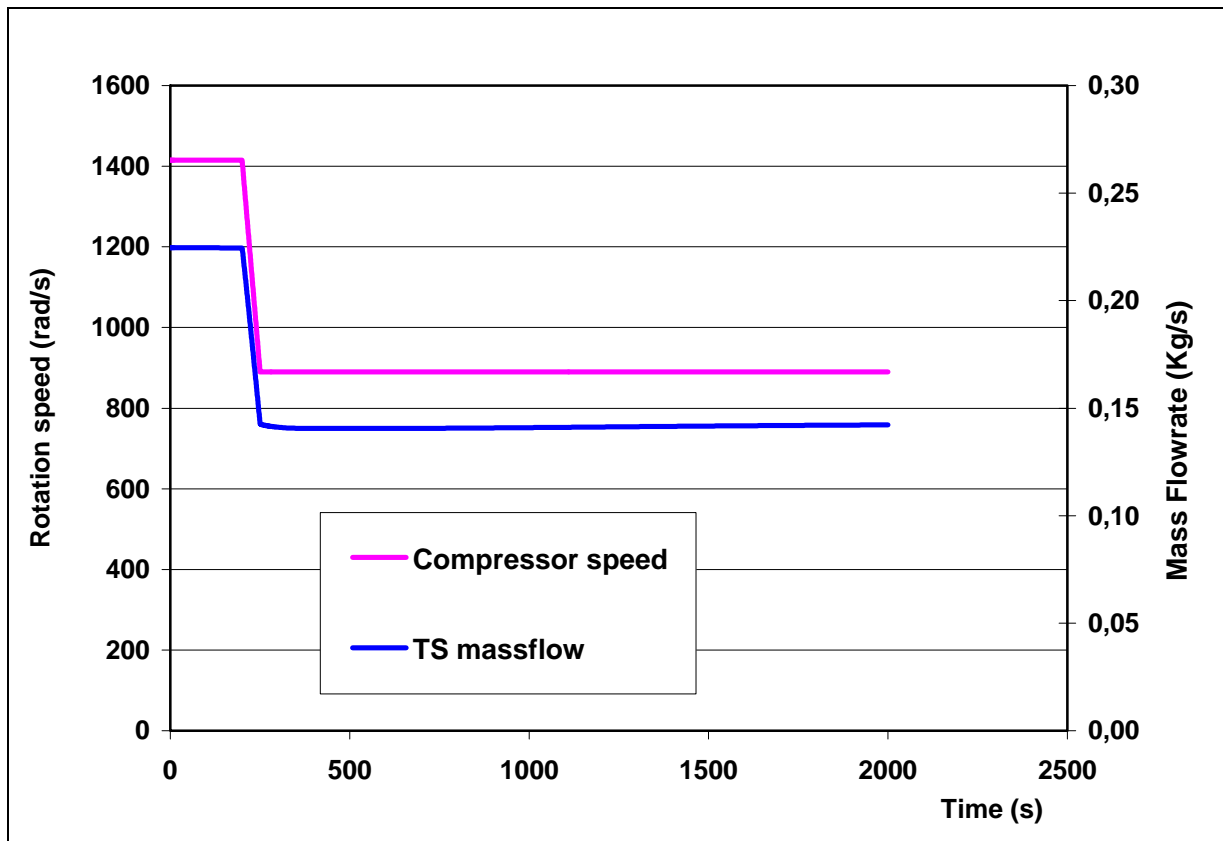

Fig. 4.10 – Compressor Speed and TS Mass Flowrate

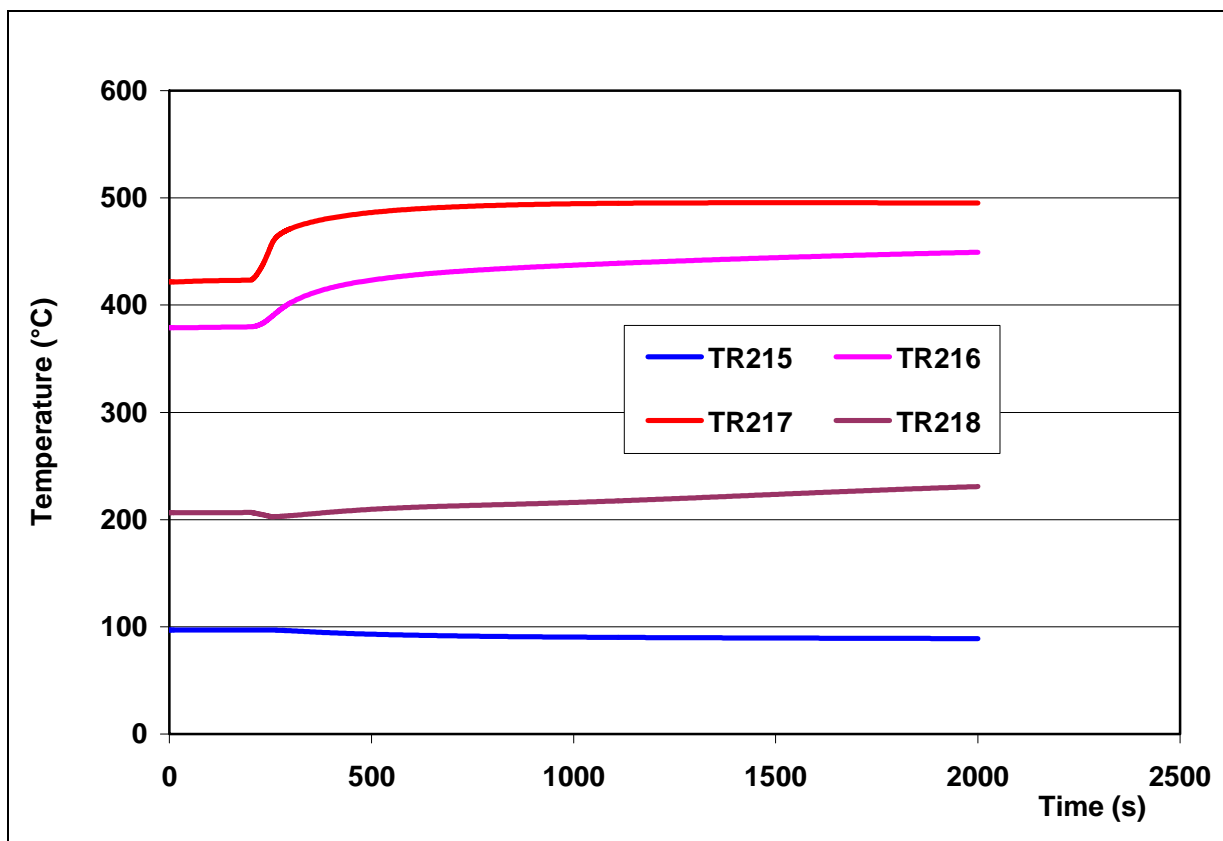

Fig. 4.11 – Inlet and Outlet Economizer Temperatures

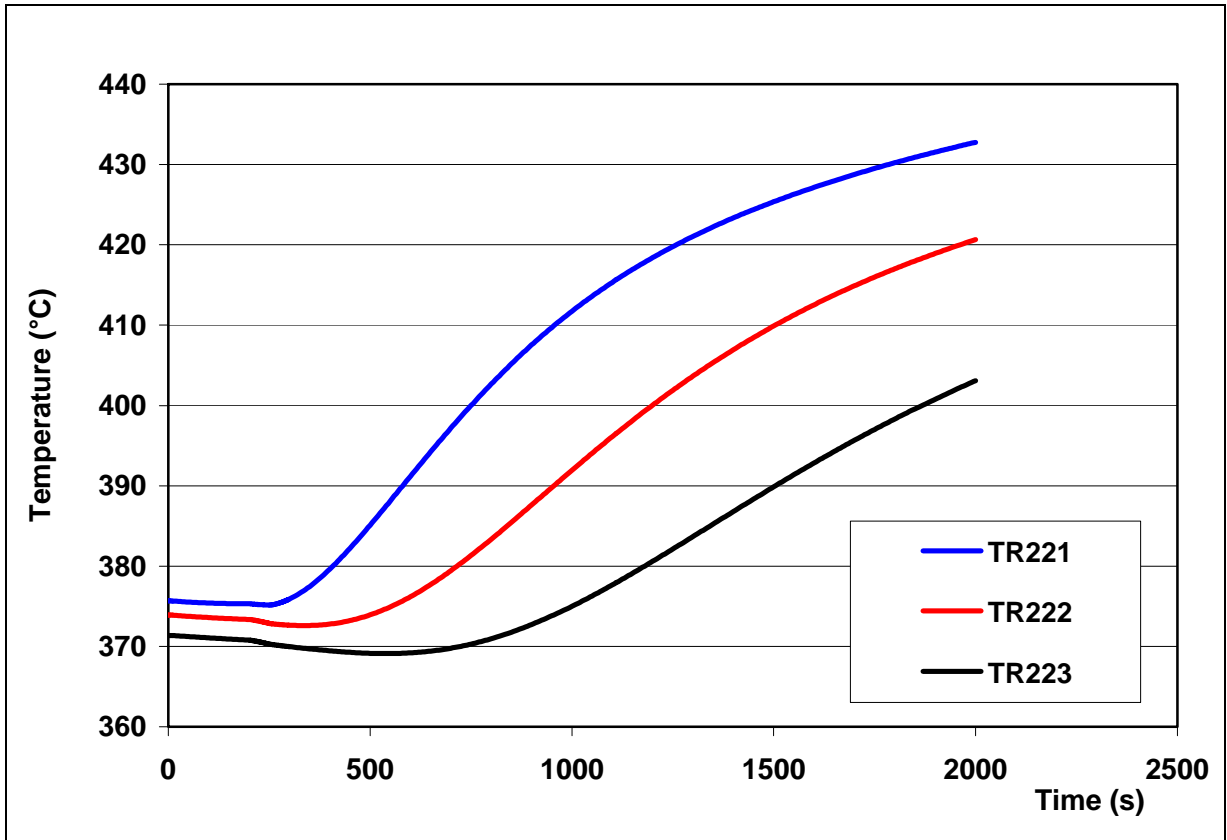

Fig. 4.12 – Heaters Zone Temperatures

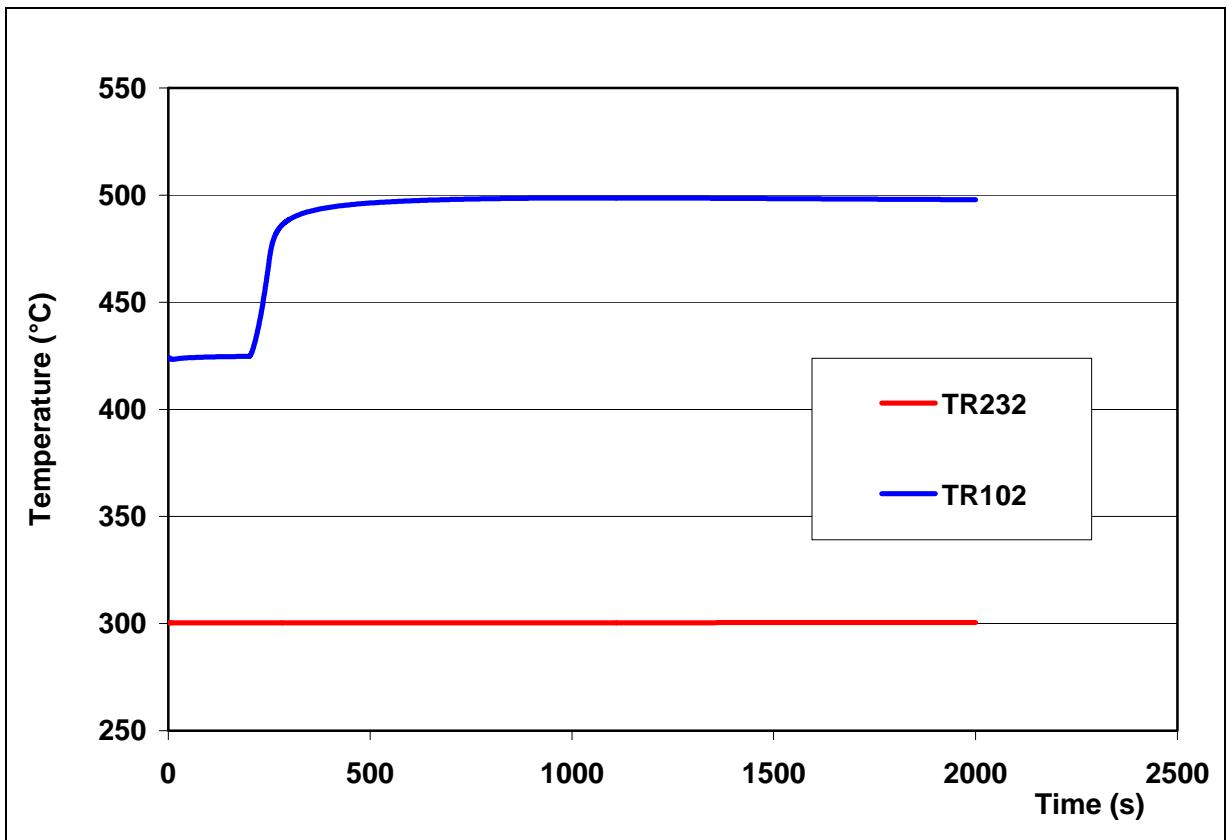

Fig. 4.13 – Inlet and Outlet Test Section Pressure Temperatures

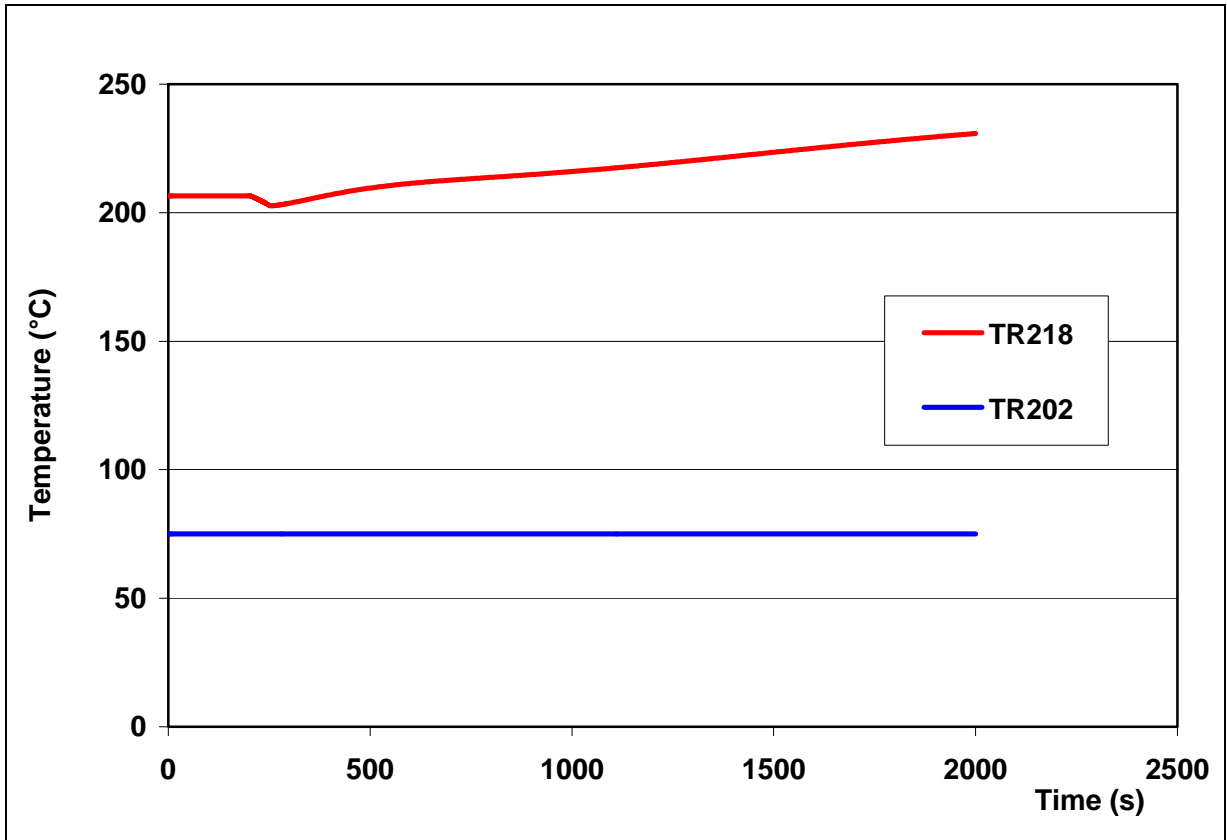

Fig. 4.14 – Inlet and Outlet Air Cooler Temperatures

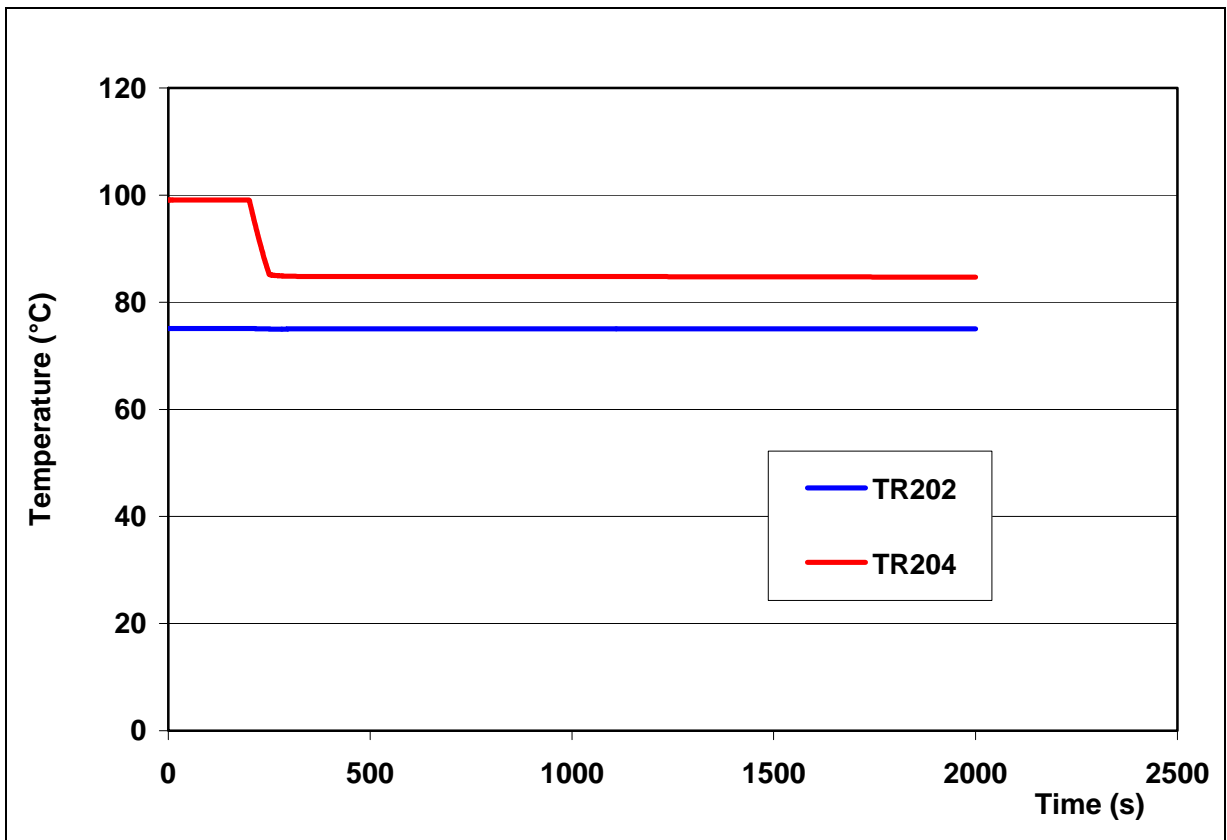

Fig. 4.15 – Inlet and Outlet Compressor Temperatures

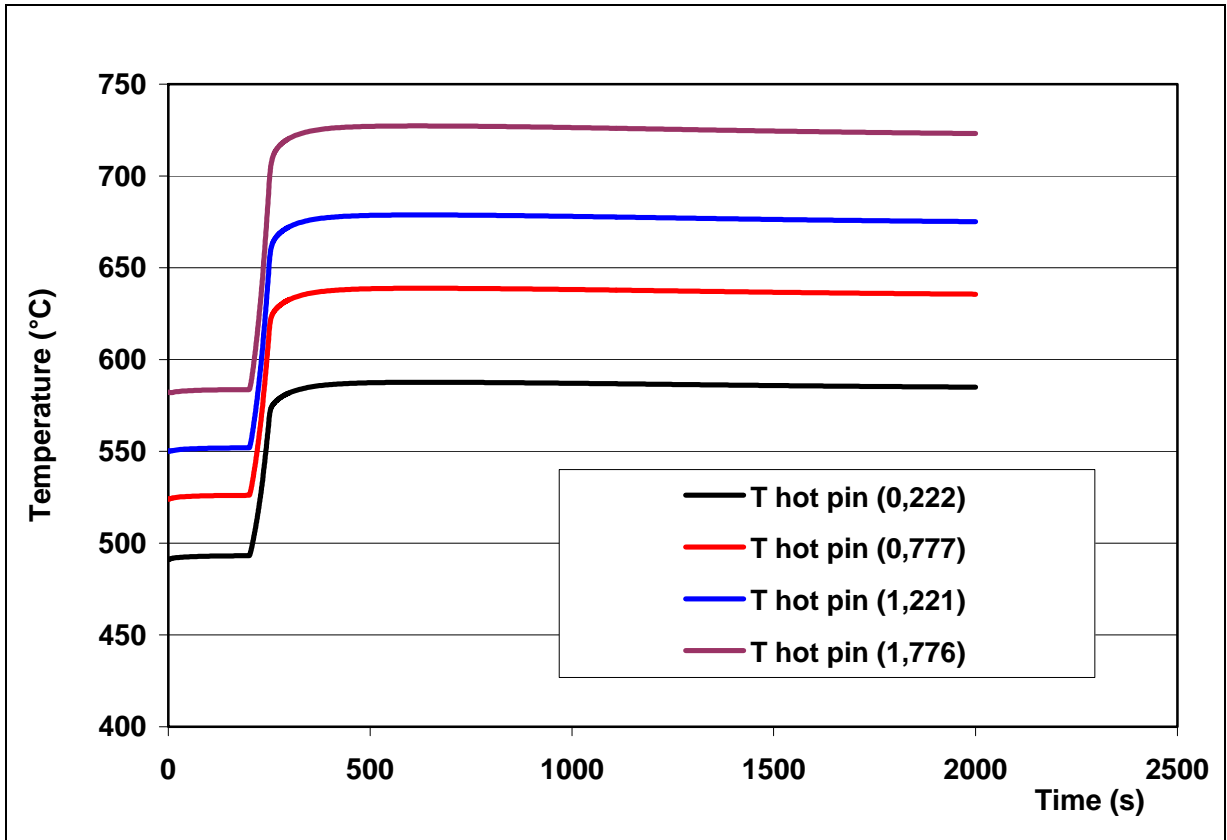

Fig. 4.16 – Hot Pin temperatures

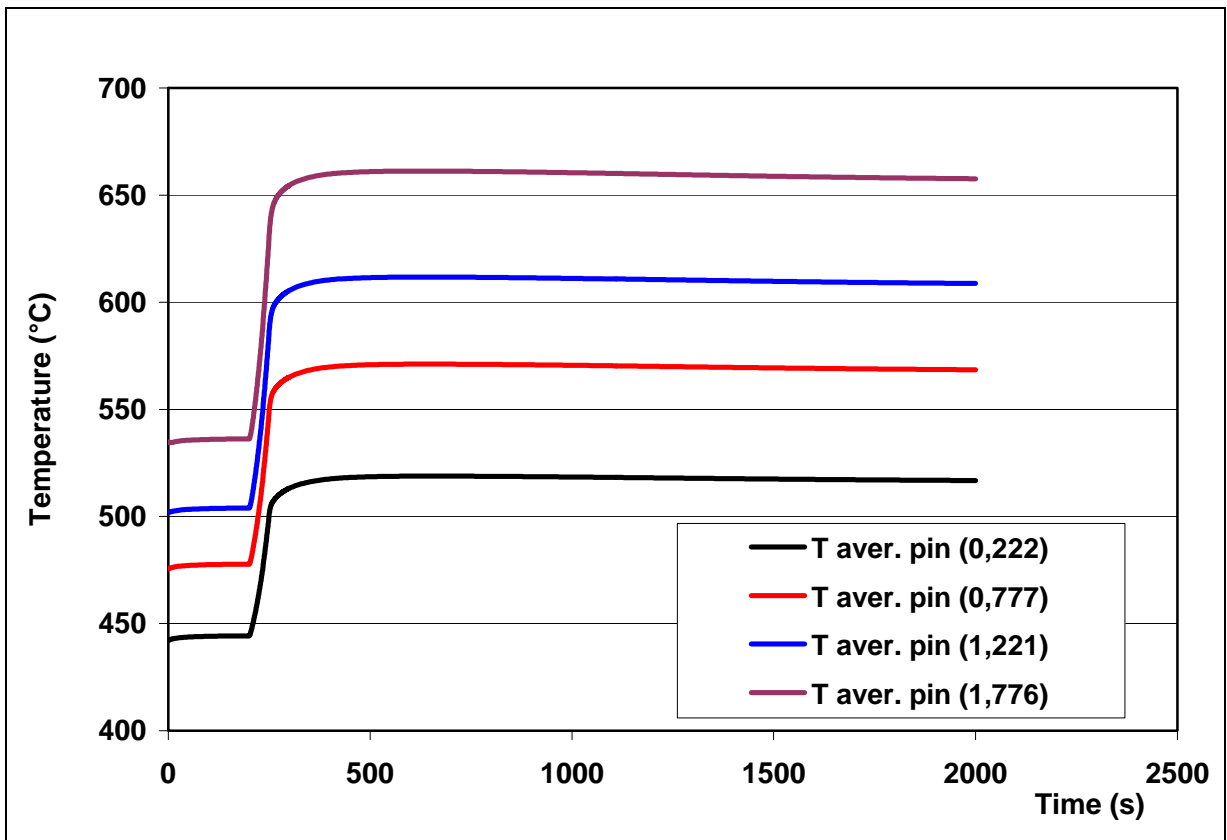

Fig. 4.17 – Average Pin temperatures

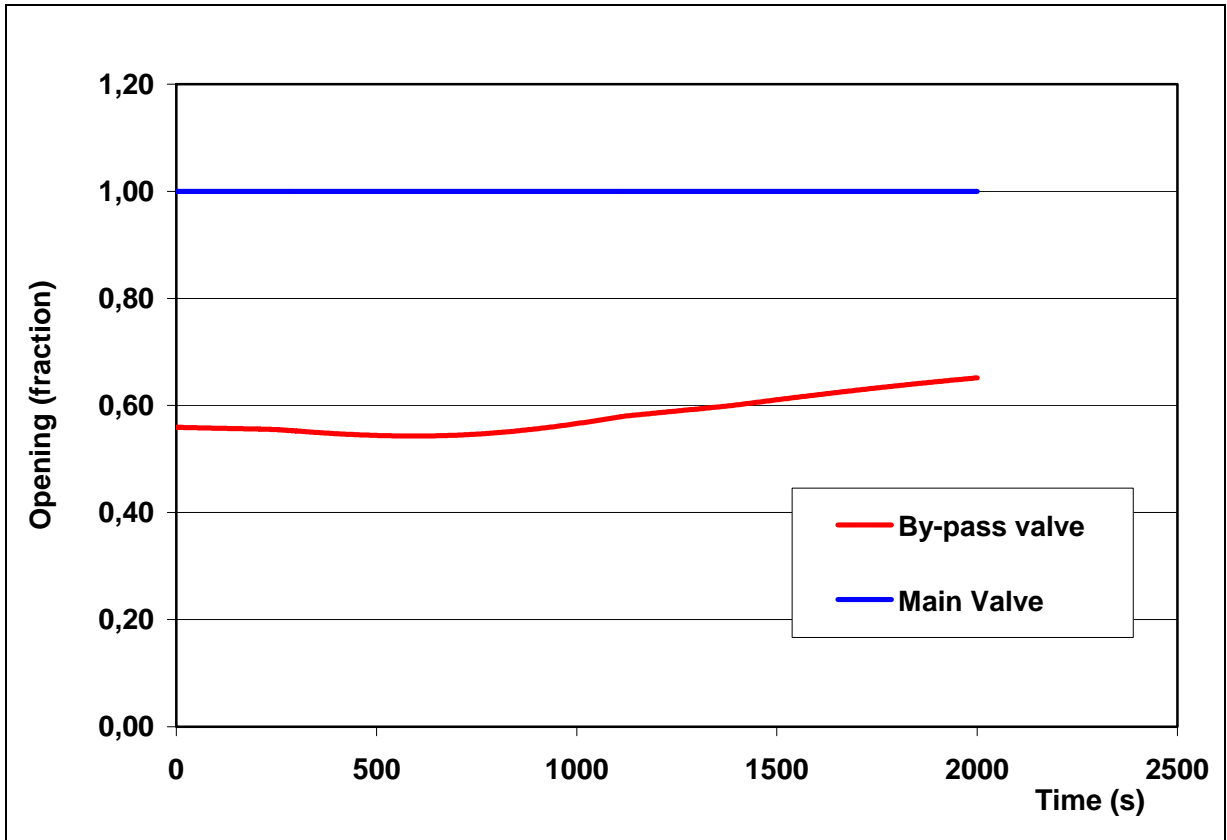

Fig. 4.18 – Main and Bypass Valves Opening

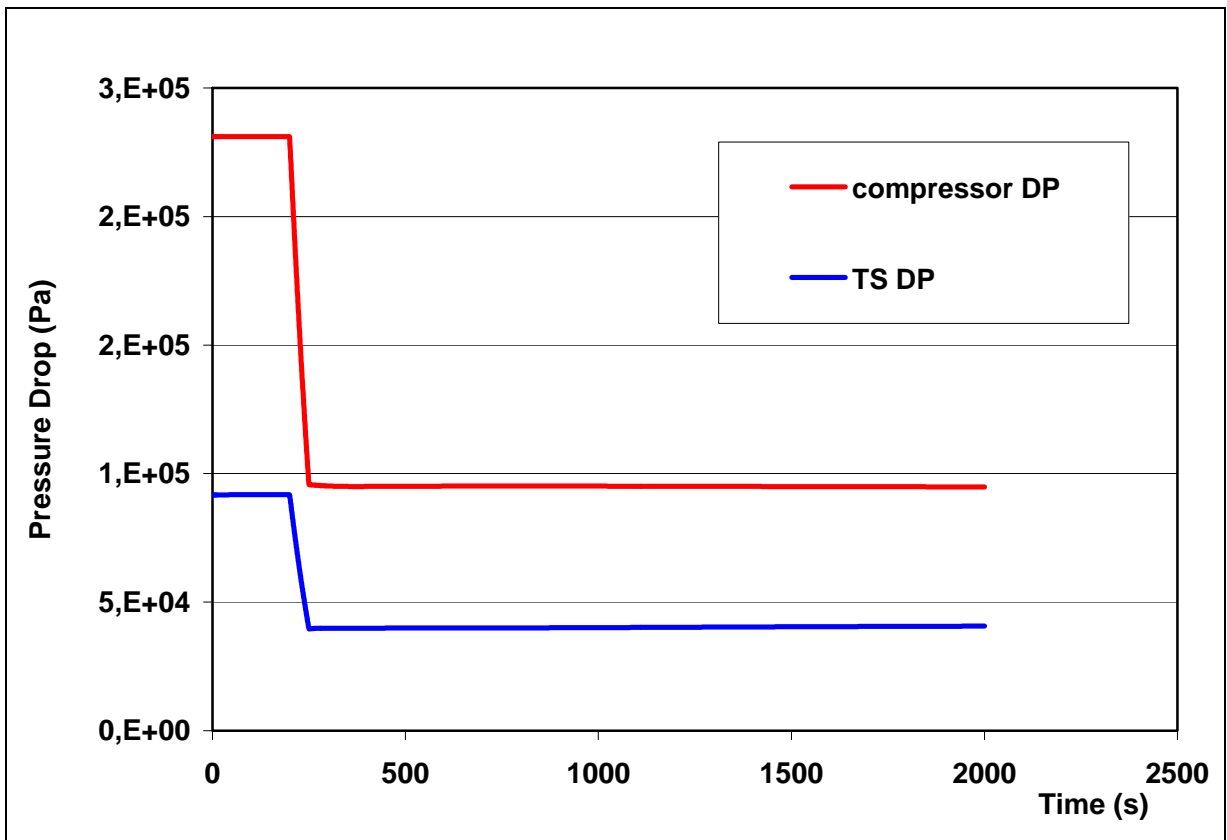

Fig. 4.19 – Loop and TS pressure Drops

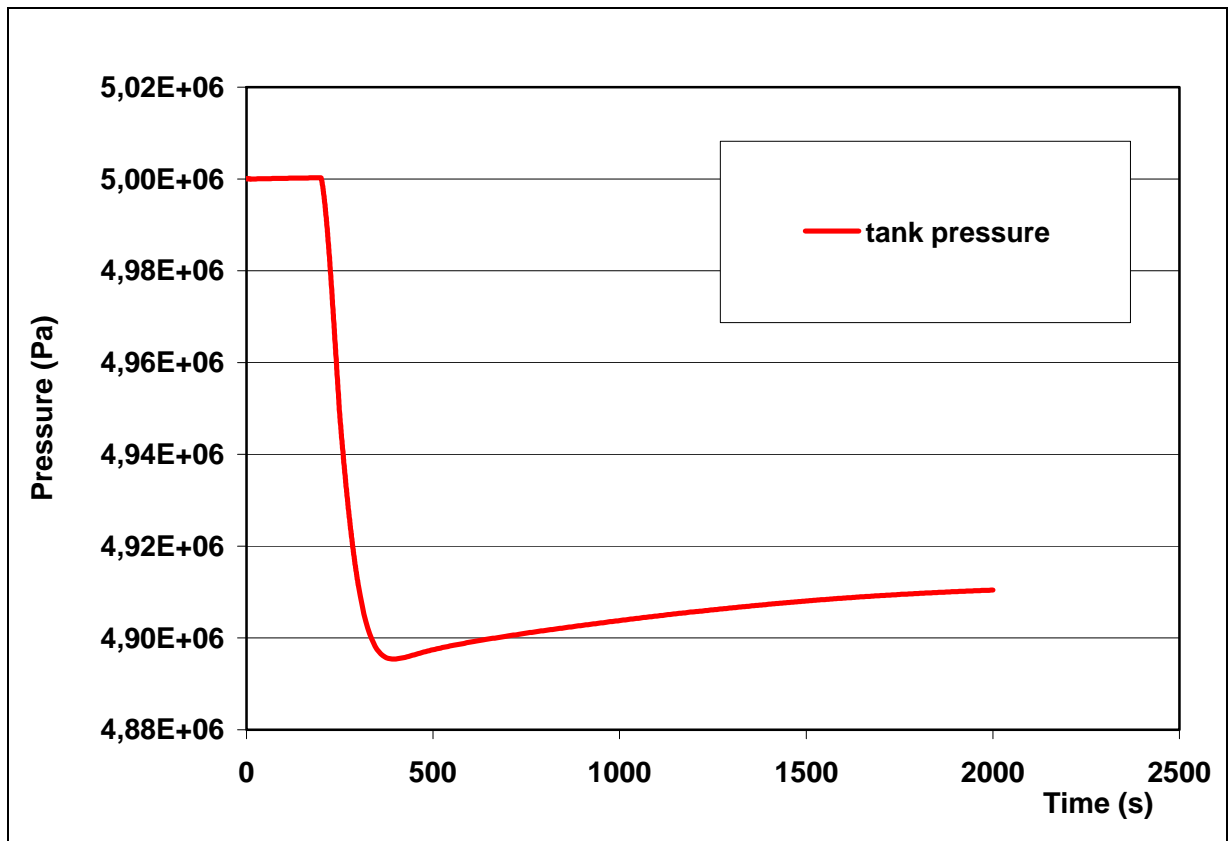

Fig. 4.20 – Loop Pressures

 Ricerca Sistema Elettrico	Sigla di identificazione	Rev.	Distrib.	Pag.	di
	NNFISS – LP3 - 002	0	L	30	134

4.3 Transient of Power (TOP)

In order to simulate the typical thermal-hydraulic conditions following an increase of fission power in the core (e.g. Reactivity Insertion Accident), a Transient of Power (TOP) driven by an increase of the Test Section electrical power is planned in the HE-FUS3 facility. In the pre-test calculation here described all the other relevant conditions are maintained at the initial values. In particular, the temperature at the inlet of the test section has not been regulated, so the helium conditions at the inlet of the 7-pin bundle are subject to an important variation that is interesting to investigate in terms of the effect on the heat transfer conditions in the bundle. It is important to guarantee that the maximum helium and pin cladding temperatures reached during the transient will not exceed the design limits, thus provoking the shutdown of the power and the stop of the test. The pre-test calculation has lasted 4500 seconds, including 200 seconds of steady state conditions in order to attain nearly the maximum values of these temperatures, because without regulation the temperature peaks depend on the loop response, which is strongly influenced by the thermal capacity. The results of the calculation reported in Figs. 4.21 to 4.30 show that in order to have a sufficient margin respect to these limits the temperature at the inlet of the test section has to be limited to opportune value.

The TOP scenario, which has started from the steady state conditions characterized by 13500 rpm of compressor speed and 90 kW of power supplied in the Test Section, has been simulated by means of an instantaneous increase of the power up to 150 kW. The initial and boundary conditions of the transient are reported in Table 4.3.

Figure 4.21 shows that, due to the increase of Power and consequently the increase of temperature in the loop, the TS mass flowrate has a very slight decrease. The increase of temperature is substantially due to the increase of power. The maximum helium temperature at the TS outlet reaches 518 °C (Fig. 4.24) after 3800 seconds of transient, nevertheless the temperature is not stabilized and is still increasing. In order to remain below the design limit of 530 °C with a sufficient margin, it is recommendable to avoid that the temperature at the inlet of the Test Section exceeds 390 °C. In the calculation this temperature achieves 395° (Fig. 4.23) while the temperature through TS is stable at 124 °C. Instead, the maximum pin temperature in Fig. 4.27 is well below the design limit also without controlling the TS inlet temperature.

After the 3800 sec transient calculated the loop temperature is not still stabilized and the peak temperatures are not still reached due to the thermal inertial of the loop structures. Because the trends of the temperatures still show consistent increases it is recommended to extend to 5000 seconds the duration of this experimental transient.

Initial and Boundary Conditions	Value	Time (s)
Initial Pressure (bar)	50.	0.
Initial Compressor Speed (rpm)	13500.	0.
TS Electrical Power (kW)	90.	0.
TS Electrical Power start increasing (kW)	90.	200.
TS Electrical Power stop increasing (kW)	150.	200.1
TS Helium Inlet Temperature (°C)	Not regulated	All transient
Air Cooler Helium Outlet Temperature (°C)	75.	All transient
Valve F213 % Opening	100.	All transient

Table 4.3 – Initial and boundary conditions for Transient of Power

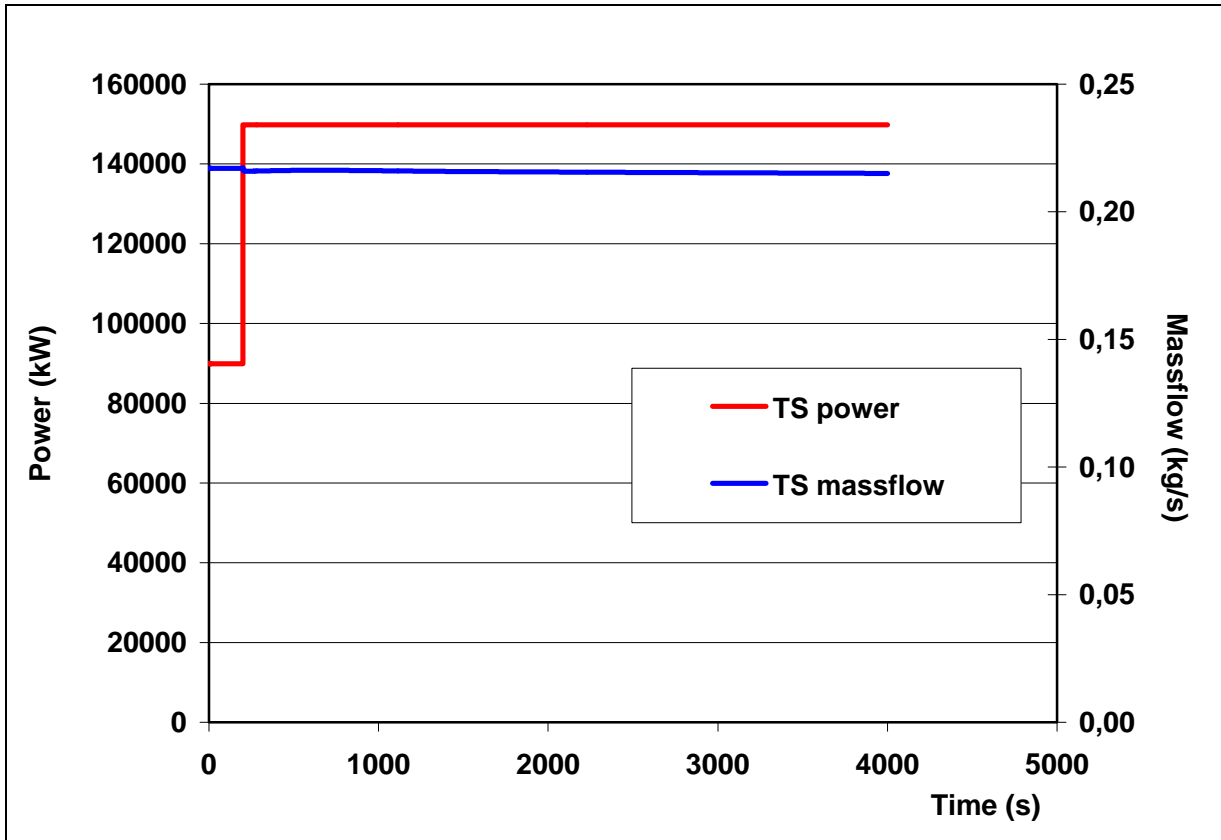

Fig. 4.21 – Test Section Power and Mass Flowrate

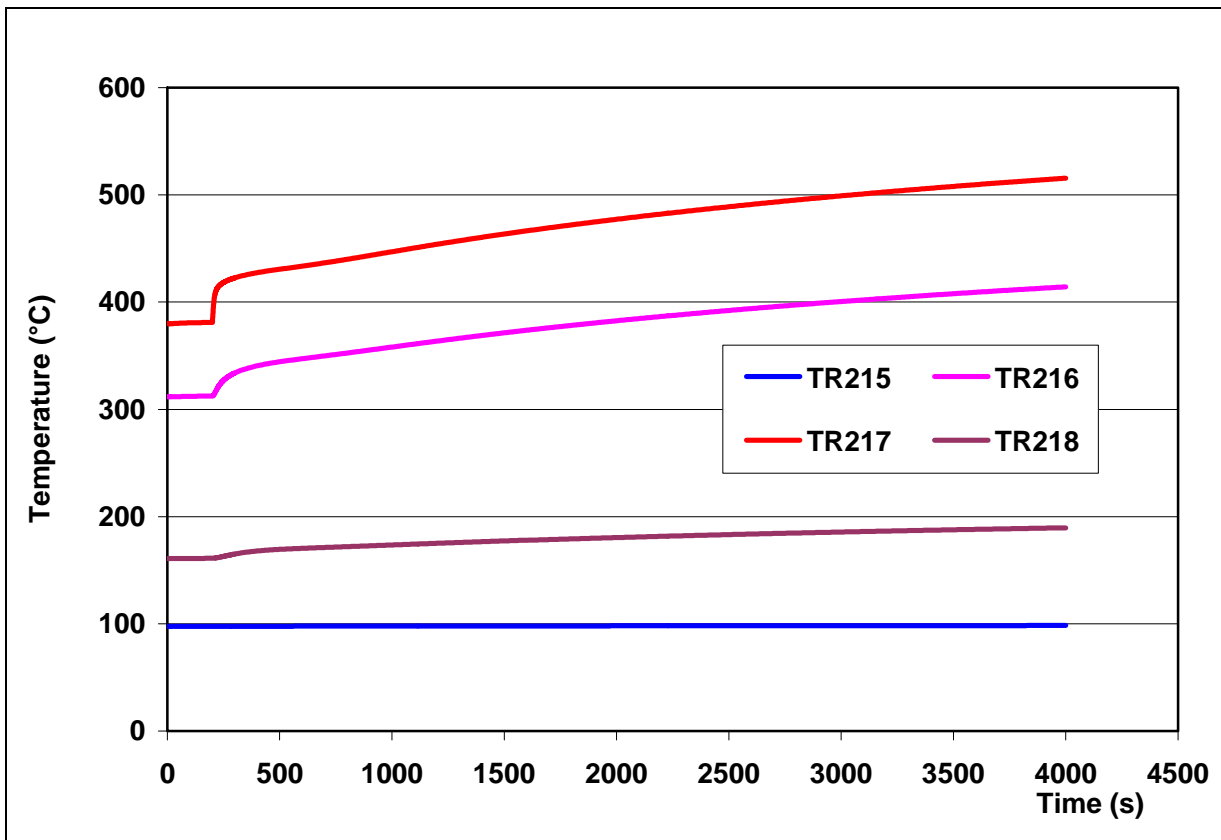

Fig. 4.22 – Inlet and Outlet Economizer Temperatures

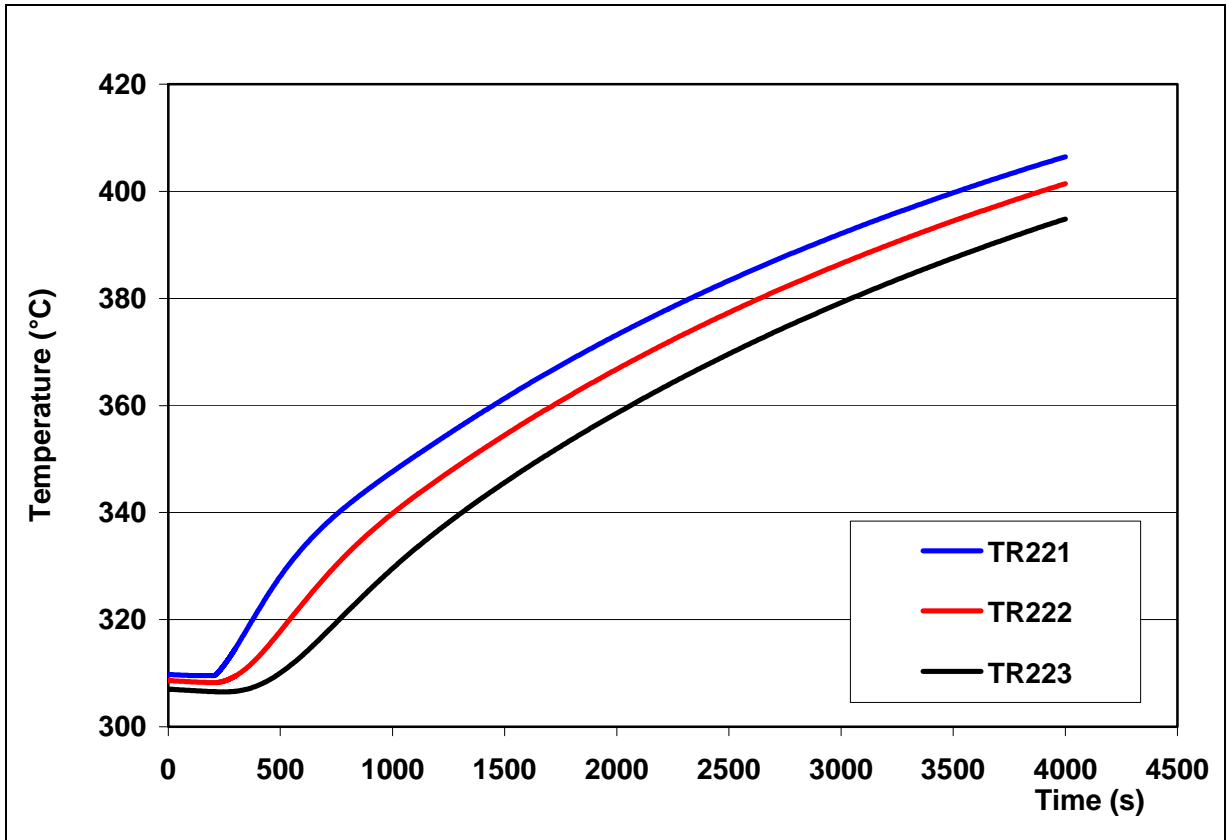

Fig. 4.23 – Heaters Zone Temperatures

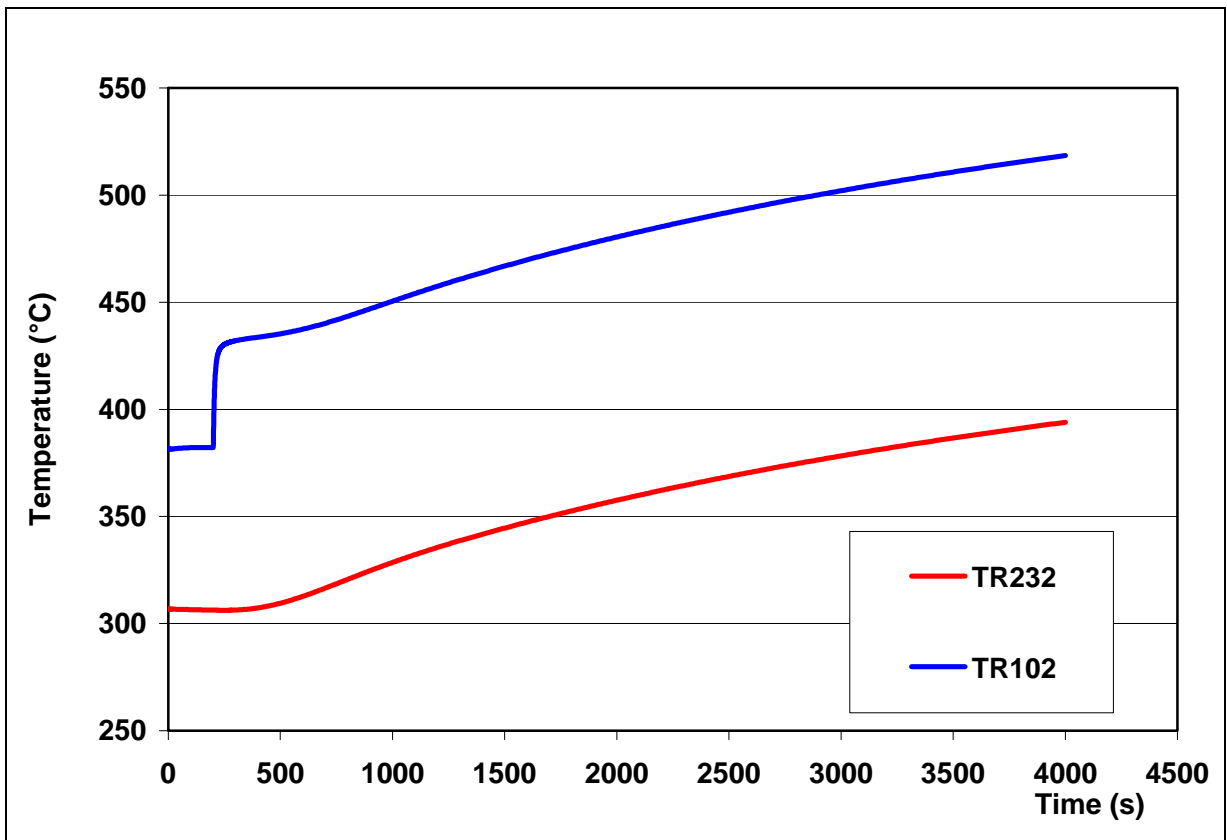

Fig. 4.24 – Inlet and Outlet Test Section Pressure Temperatures

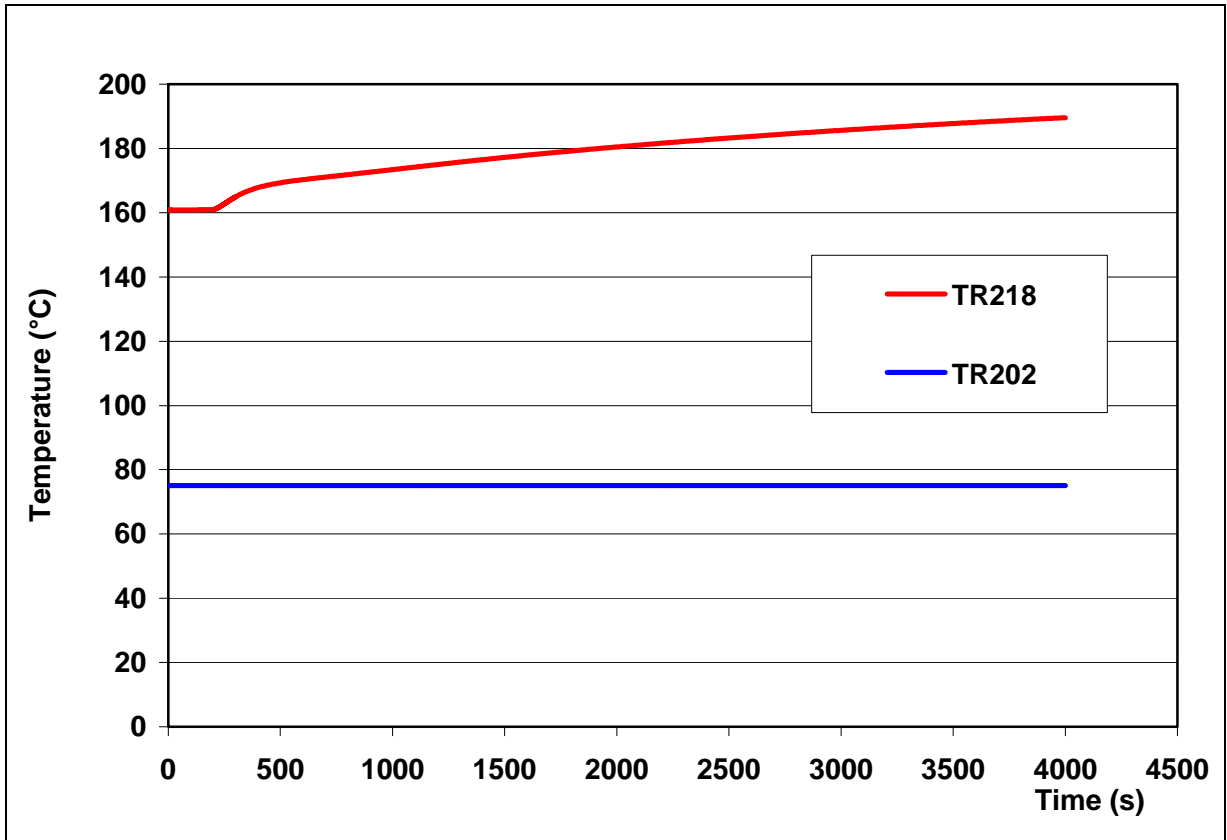

Fig. 4.25 – Inlet and Outlet Air Cooler Temperatures

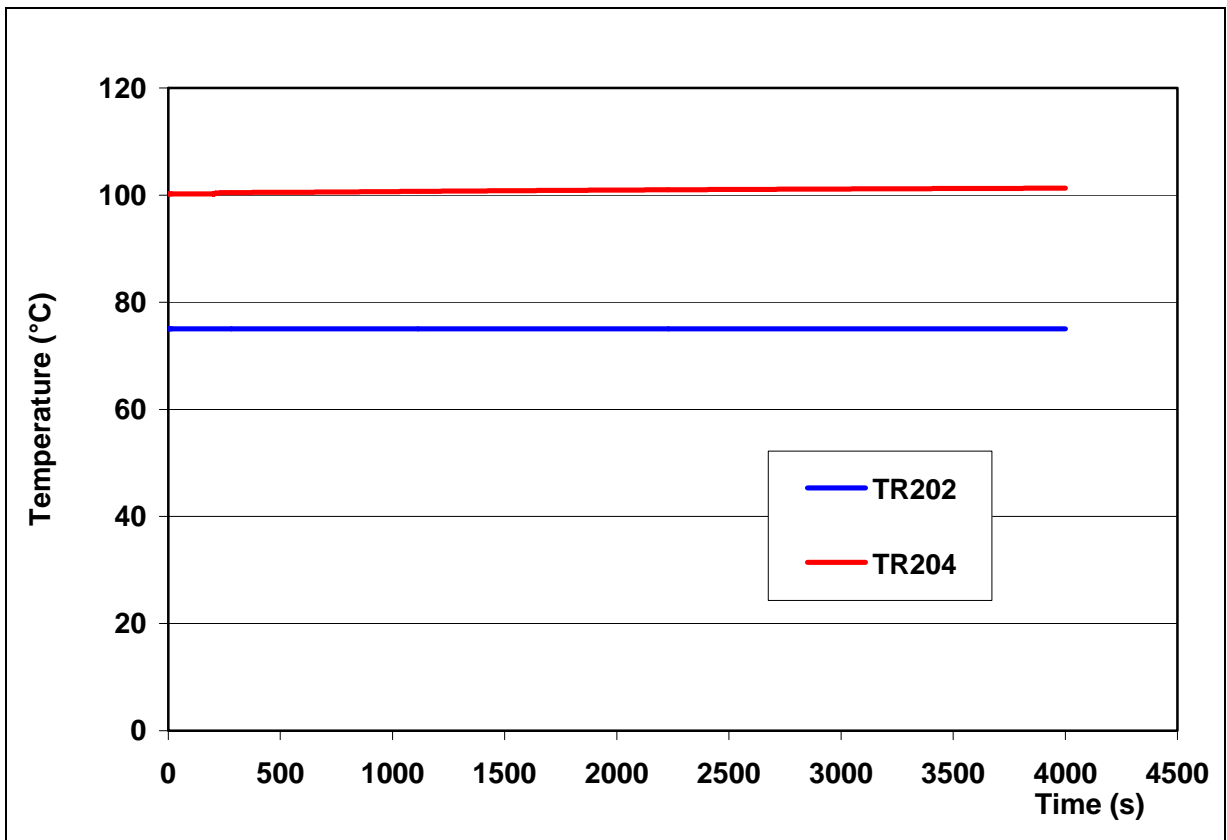

Fig. 4.26 – Inlet and Outlet Compressor Temperatures

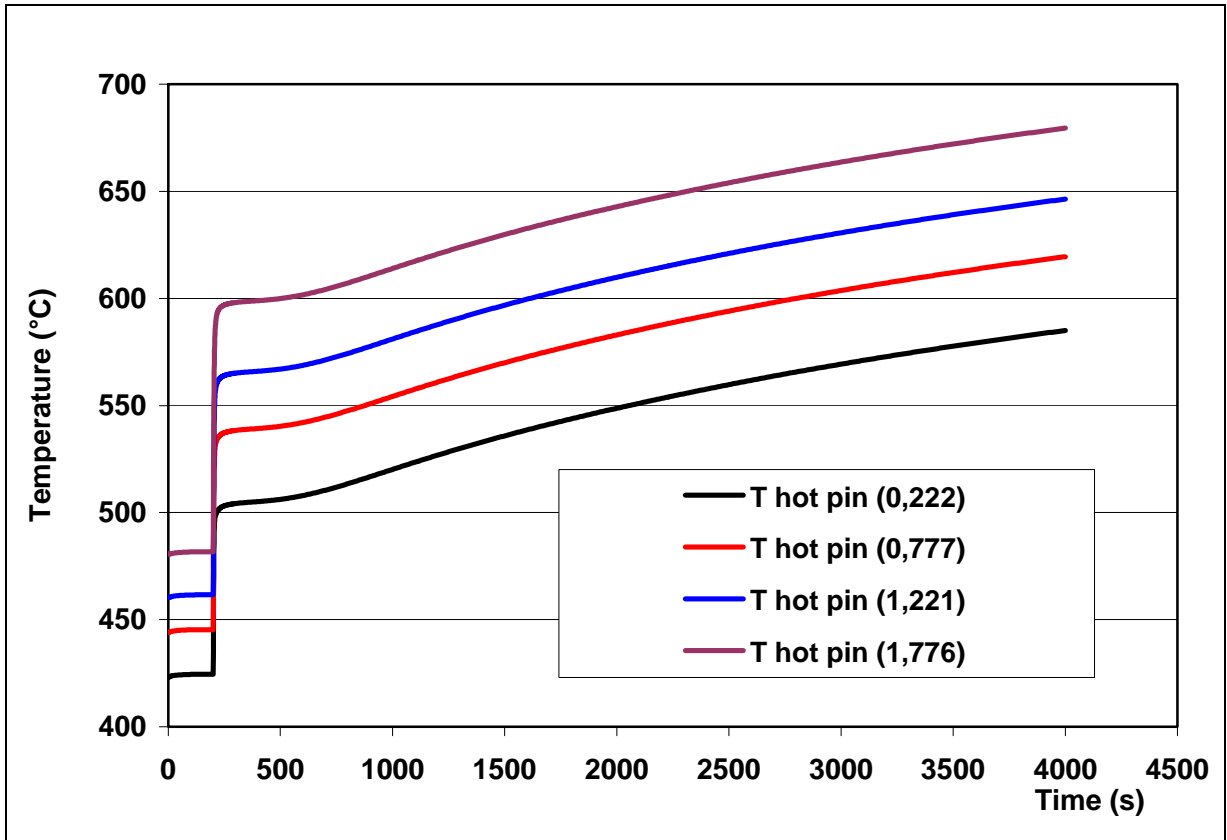

Fig. 4.27 – Hot Pin temperatures

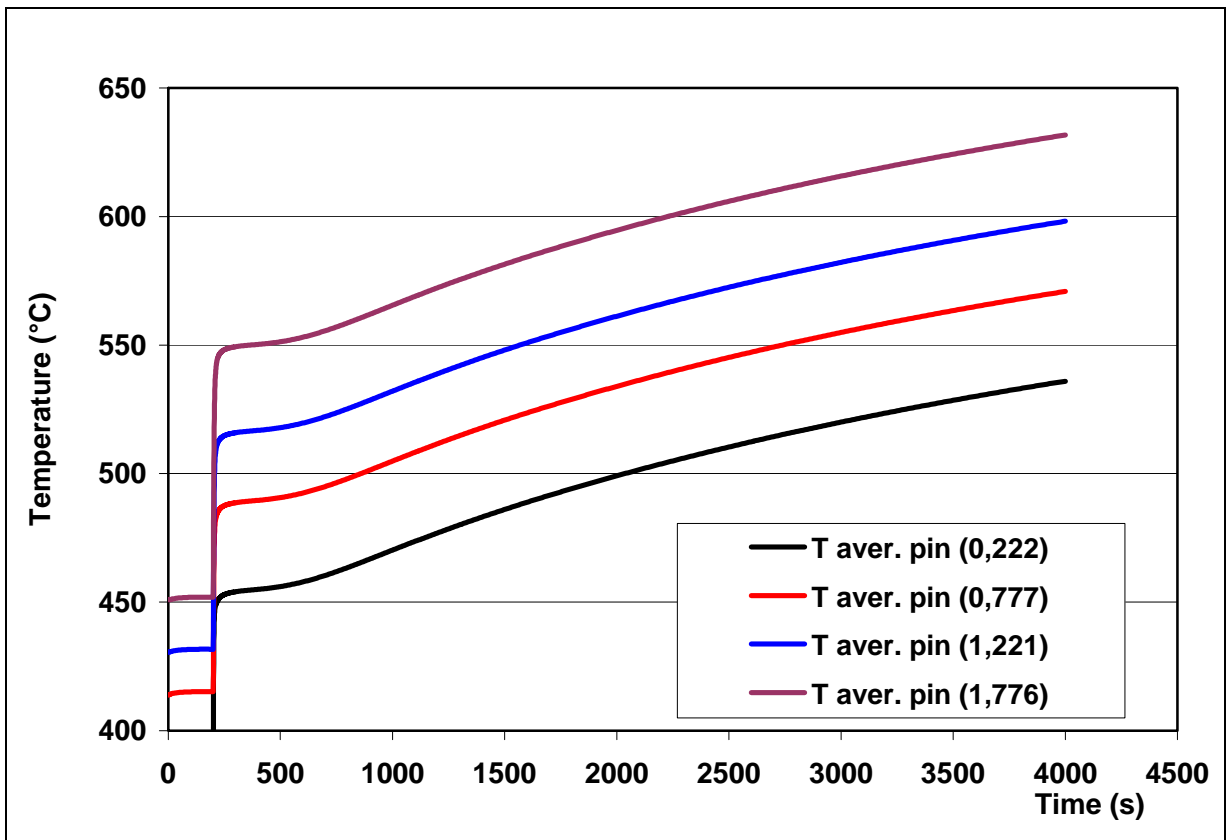

Fig. 4.28 – Average Pin temperatures

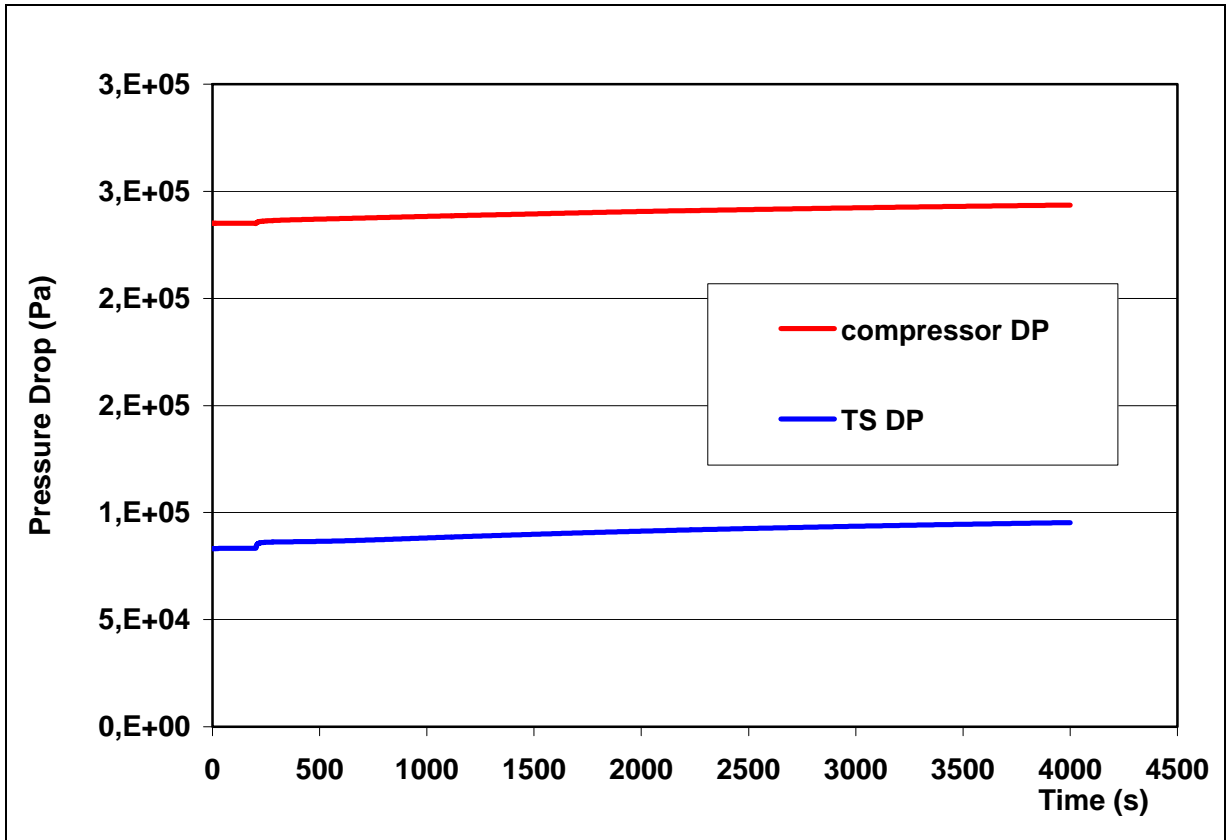

Fig. 4.29 – Loop and TS pressure Drops

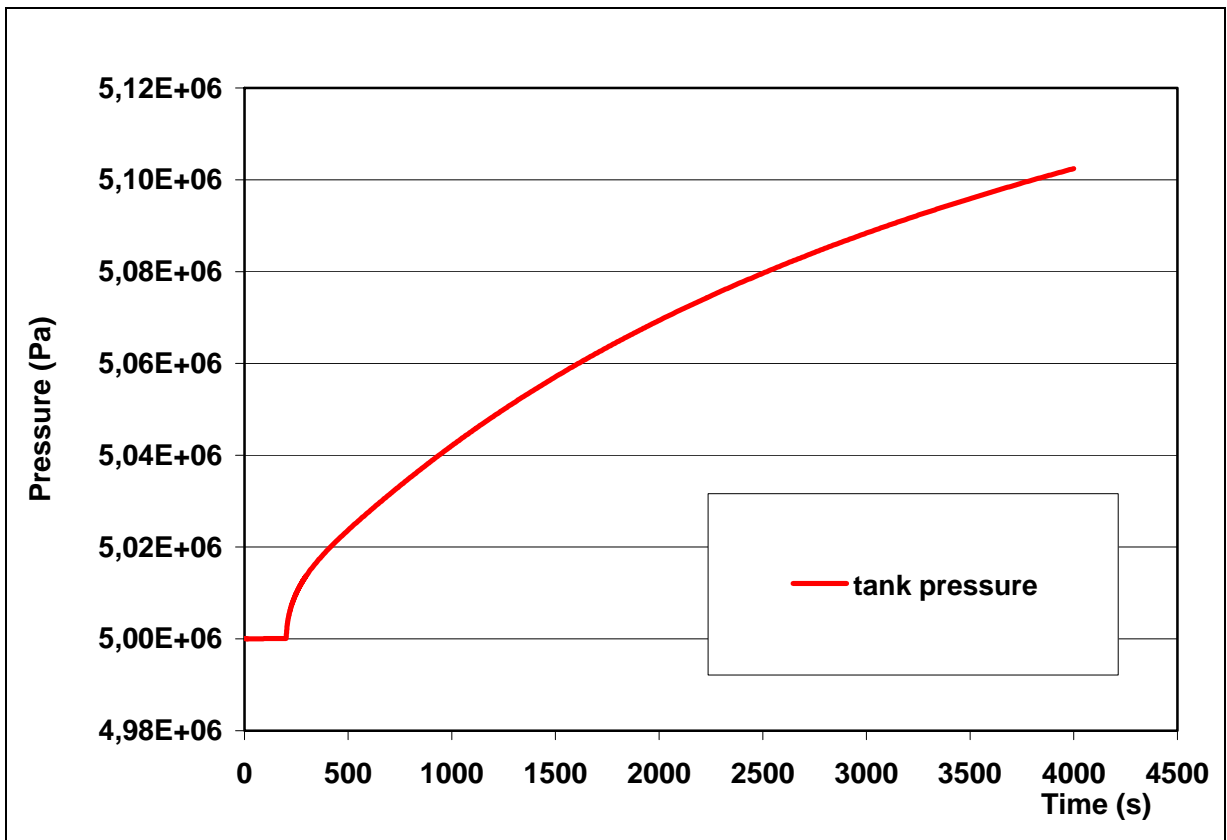

Fig. 4.30 – Loop Pressures

 Ricerca Sistema Elettrico	Sigla di identificazione	Rev.	Distrib.	Pag.	di
	NNFISS – LP3 - 002	0	L	37	134

4.4 LOCA Transient

A LOCA transient has been simulated starting with a loop pressure of about 50 bar, or the maximum loop pressure attainable after operating the loop for the previous transient. As described in the paragraph 2 a dedicated line was implemented on the expansion tank to simulate a break on the primary loop and to allow the measurement of the break mass flowrate. The transient will be started by opening in 3 seconds a 1 ½ inc control valve located on the expansion tank. The pre-test analysis performed has had as a main result the dimensioning of a protection valve at the end of the line that, acting like a calibrated orifice, prevents a too fast depressurization of the loop with the achievement of a temperature higher than the design value. This valve is considered necessary due to the uncertainty that affects the simulation of such a fast transient.

To this scope some parametric calculations have been performed varying the dimension of the valve from 2 inc to 0.5 inc and consequently the duration of the break opening. The results of these calculations are summarized in Table 4.4. It is evident that a seize of 2 inc has no effects and also a seize of 1 inc does not allow to control the depressurization during the LOCA transient thus preventing the intervention of the protection system, therefore a 0.5 inc valve will be installed. Moreover in order to not exceed the design temperatures the reference pre-test calculation has been run considering a break opening of 41 seconds including 3 seconds for the closure of the regulation valve.

The LOCA transient will allow to investigate that behaviour of the loop against a strong variation of the loop pressure The initial and boundary conditions of the transient are reported in Table 4.4.

The results of the calculation are reported in Figs. 4.31 to 4.40. Figure 4.31 shows the instantaneous increase of the break mass flowrate at the break opening that is limited at 0.507 kg/s by the critical conditions. During the 41 s of the break opening the loop pressure decreases down to a minimum value of 19 bar then goes up to 22 bar following the loop heating (Fig. 4.32). In the mean time loop and TS mass flowrates strongly decrease in agreement with the characteristic of the compressor and as a consequence the temperature in the hot part of the loop increases. The helium temperature at the outlet of the Test Section reaches 533 °C after 800 s from the beginning of the transient (Fig. 4.35) that slightly exceed the design temperature. In order to avoid such a high temperature it is recommended to limit the break opening of a few seconds (38 s including opening and closure times). Due to the strong degradation of the thermal exchange behaviour with the decrease of the helium velocity the peak of clad temperature in the hot pin exceed also the limit value of 800 °C of a few degrees (Fig. 4.38).

Dimension of the manual valve	2"	1"	1/2"
Depressurization time (s) (including 3 s for valve closure)	13	17	43
Minimal Pressure (bar)	18.2	17.7	17.5
Maximum Break Flowrate (kg/s)	1.63	1.30	0.51
Maximum Helium Temp. (°C)	510.	515.	518.
Maximum Pin Temp. (°C)	780.	790.	810.

Table 4.4 – Parametric analysis on protection valve size

Initial and Boundary Conditions	Value	Time (s)
Initial Pressure (bar)	50	0.
TS Electrical Power (kW)	120.	0.
Initial Compressor Speed (rpm)	13500.	0.
Start of Break Opening (m ²)	0.	200.
Complete Break Opening (m ²)	1.114e-3	203.
Start of Break Closure (m ²)	1.114e-3	238.
Complete Break Closure (m ²)	0.	241.
Calibrated Orifice (m ²)	0.12668e-3	All transient
TS Helium Inlet Temperature (°C)	300.	All transient
Air Cooler Helium Outlet Temperature (°C)	75.	All transient
Valve F213 % Opening	100.	All transient

Table 4.5 – Initial and boundary conditions for LOCA transient

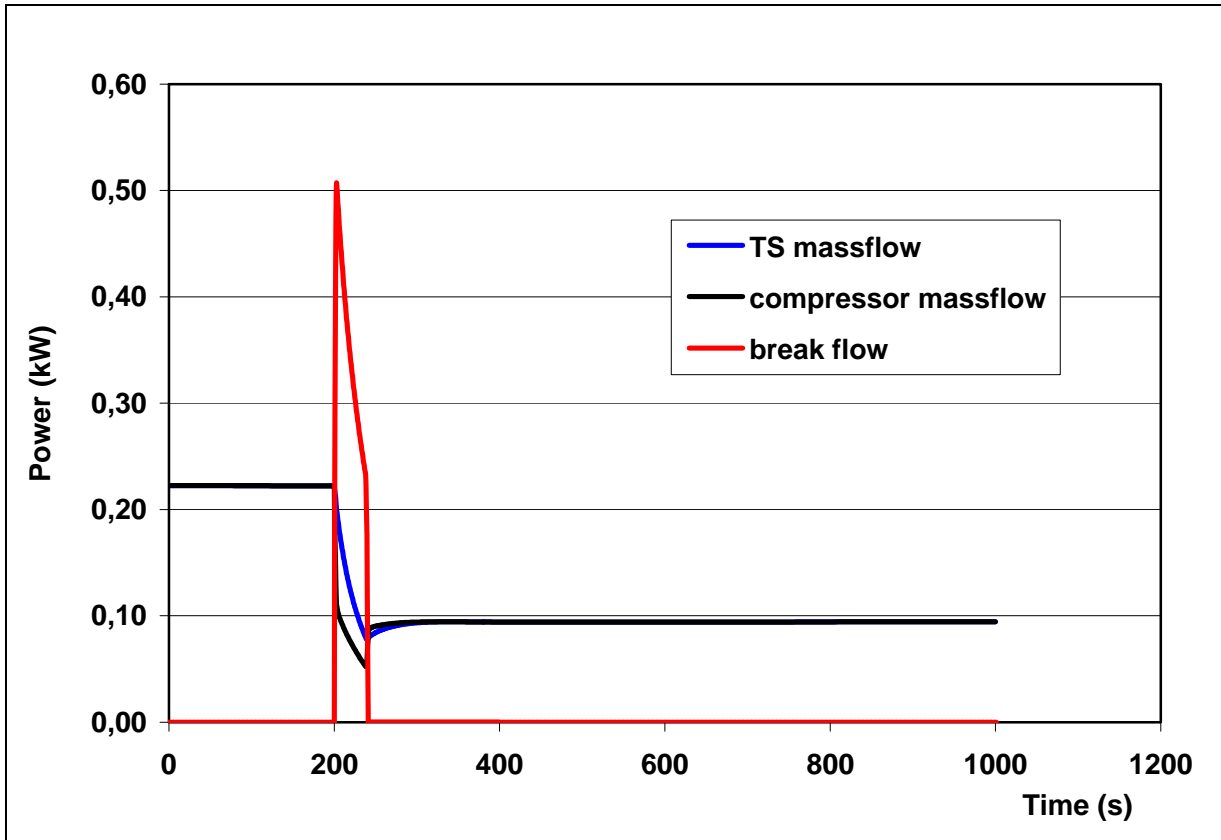
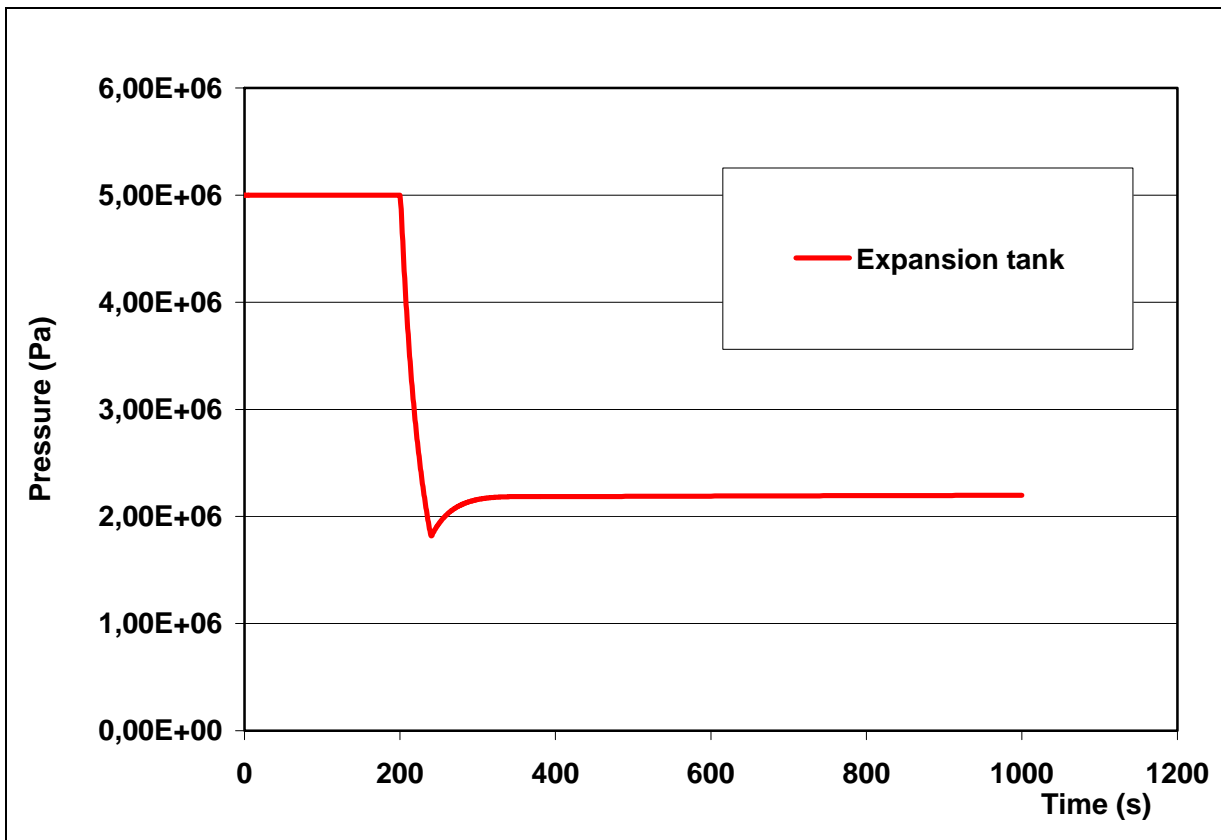

Fig. 4.31 – Test Section, Loop and Break Mass Flowrate



. Fig.4.32 – Loop Pressures

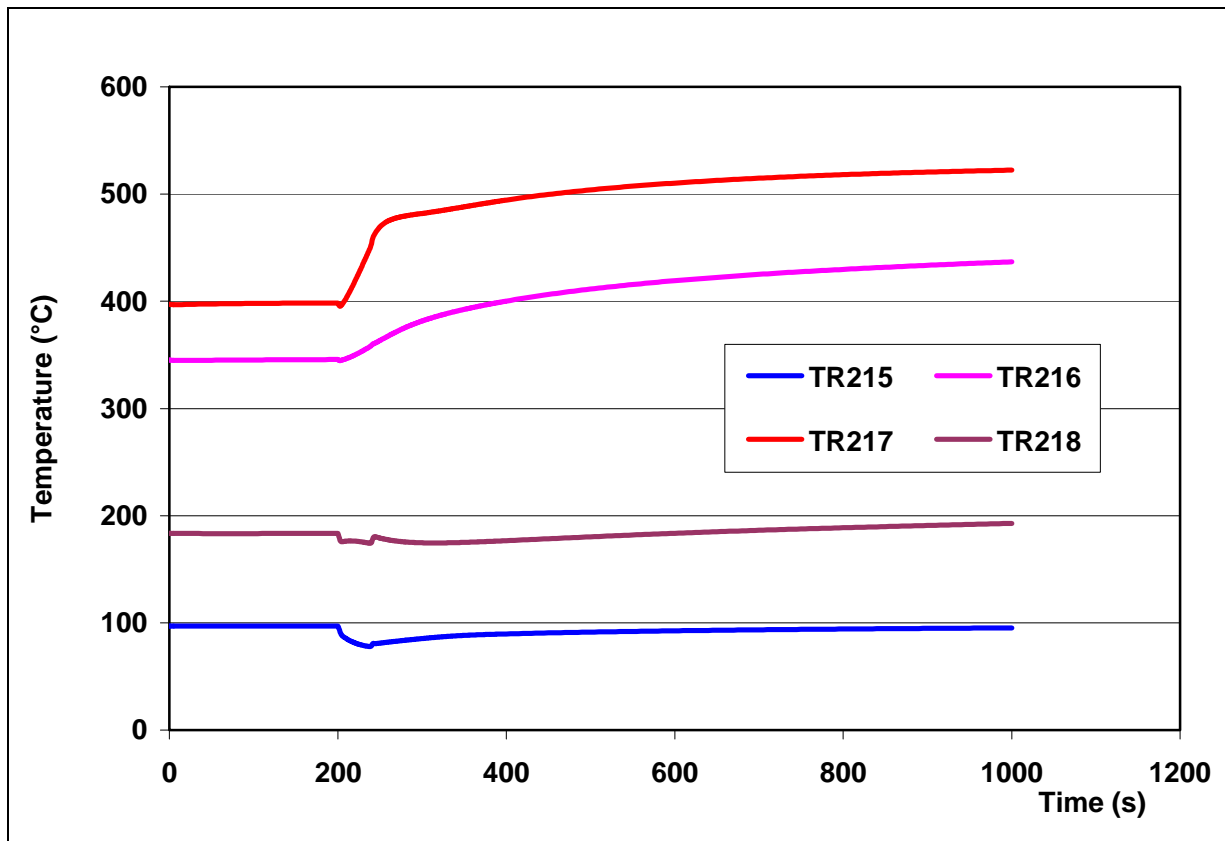

Fig.4.33 – Inlet and Outlet Economizer Temperature

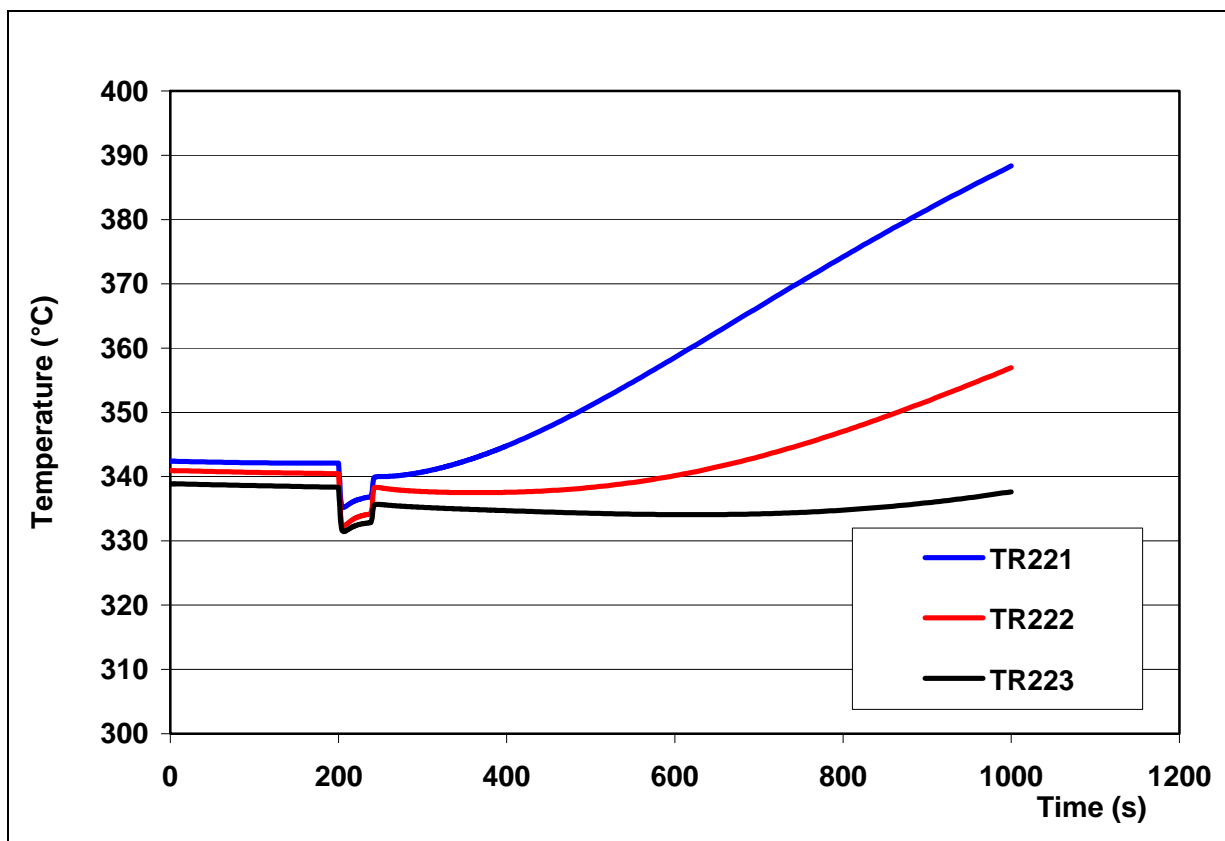

Fig. 4.34 - Heaters Zone Temperatures

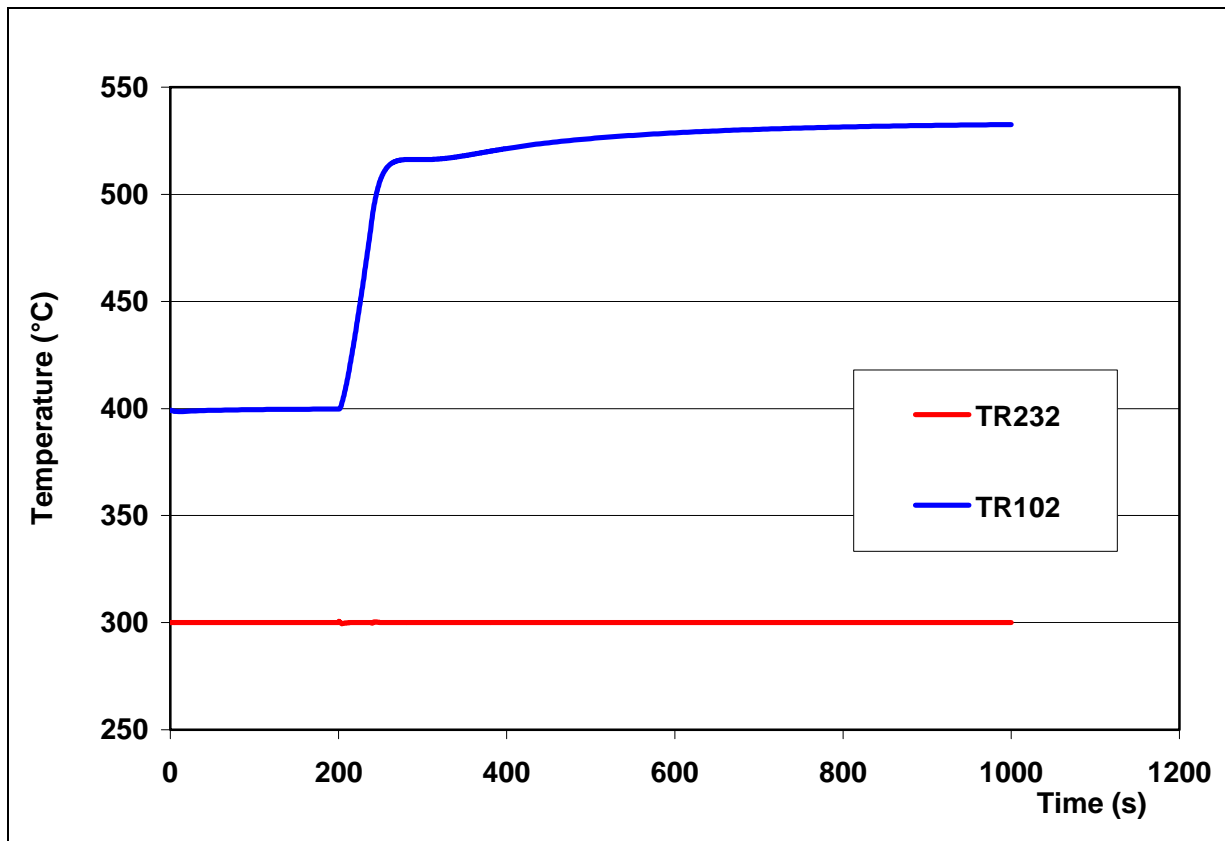

Fig. 4.35 – Inlet and Outlet TS Temperatures

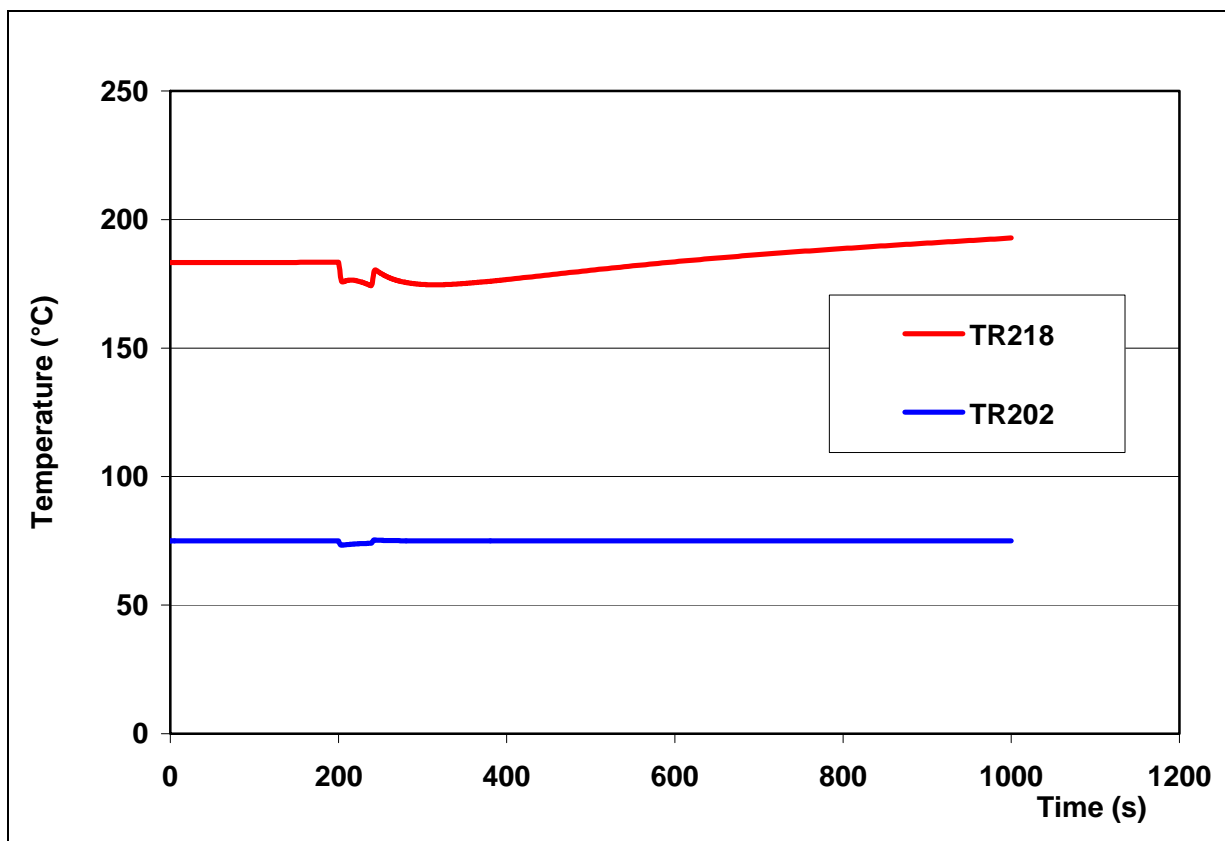

Fig. 4.36 – Inlet and Outlet Air Cooler Temperatures

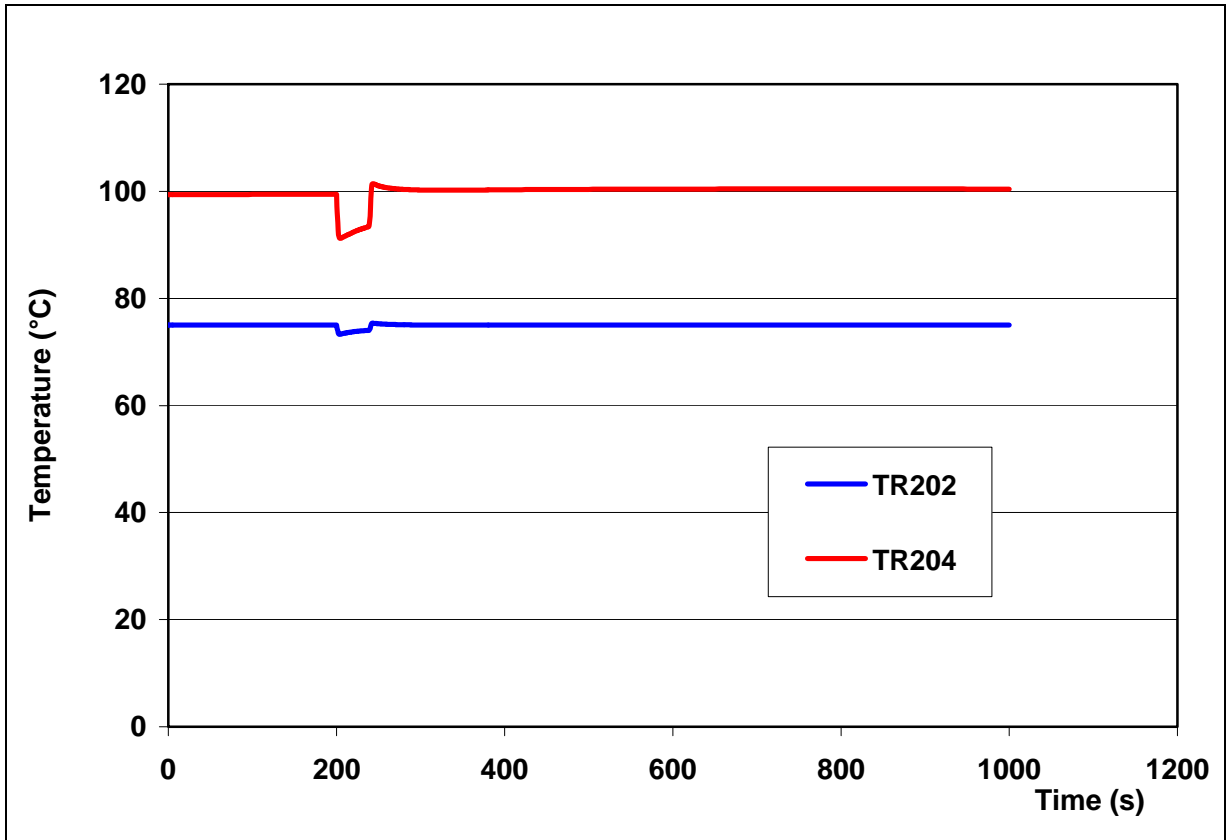

Fig. 4.37 – Inlet and Outlet Compressor Temperatures

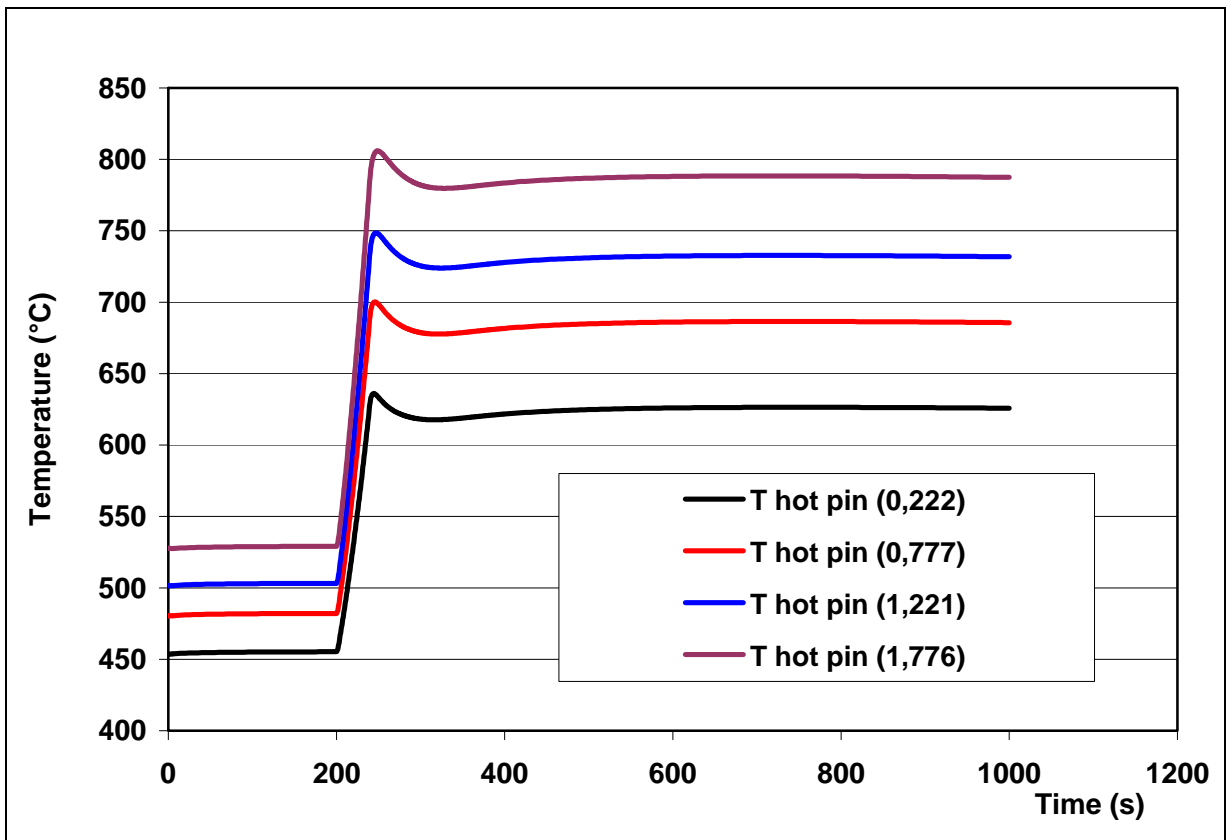

Fig. 4.38 – Hot Pin temperatures

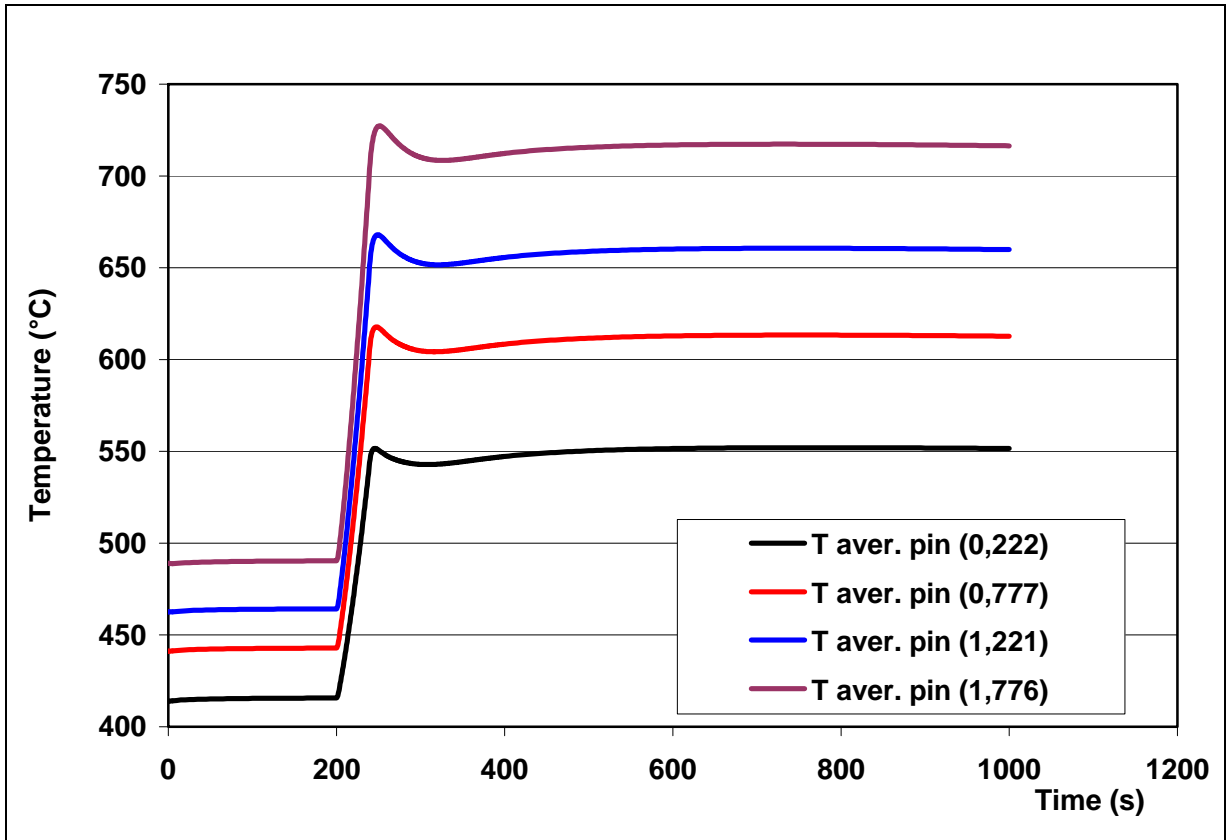

Fig. 4.38 – Average Pin temperatures

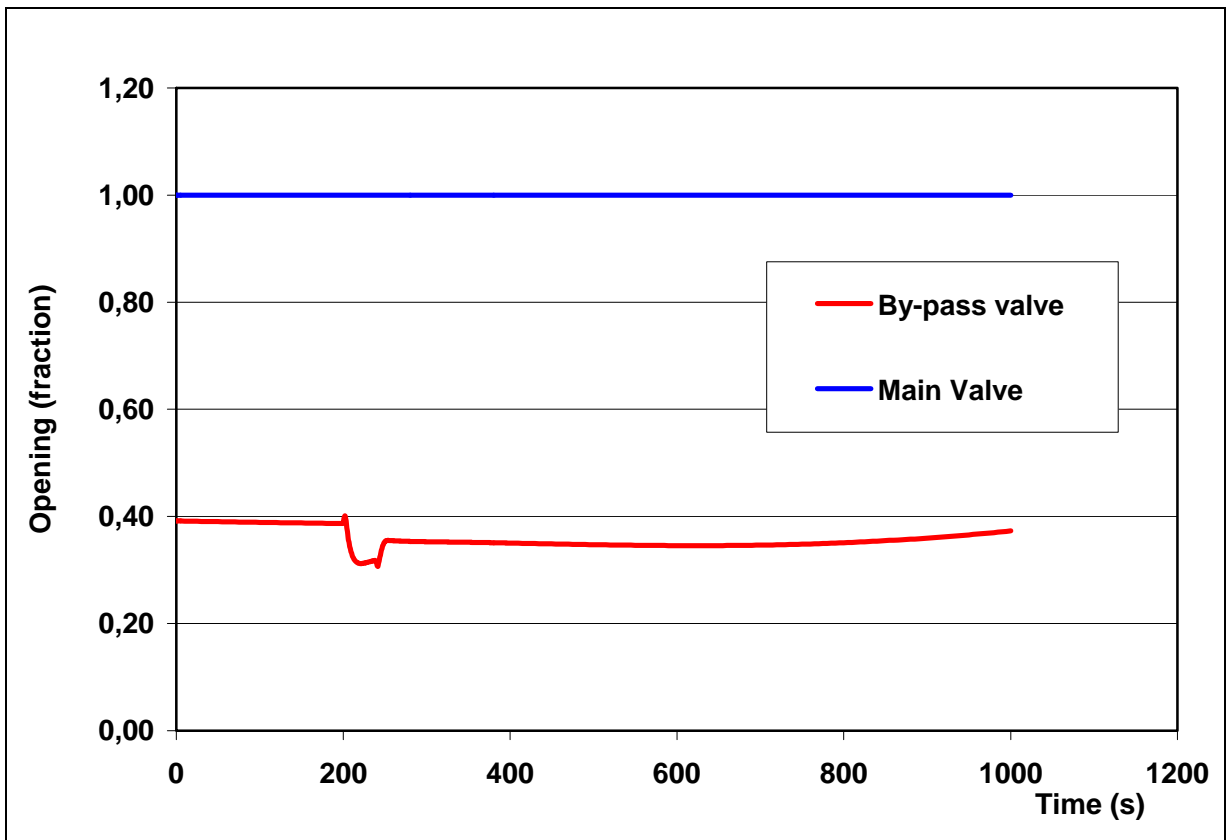

Fig. 4.39– Main and Bypass Valves Opening

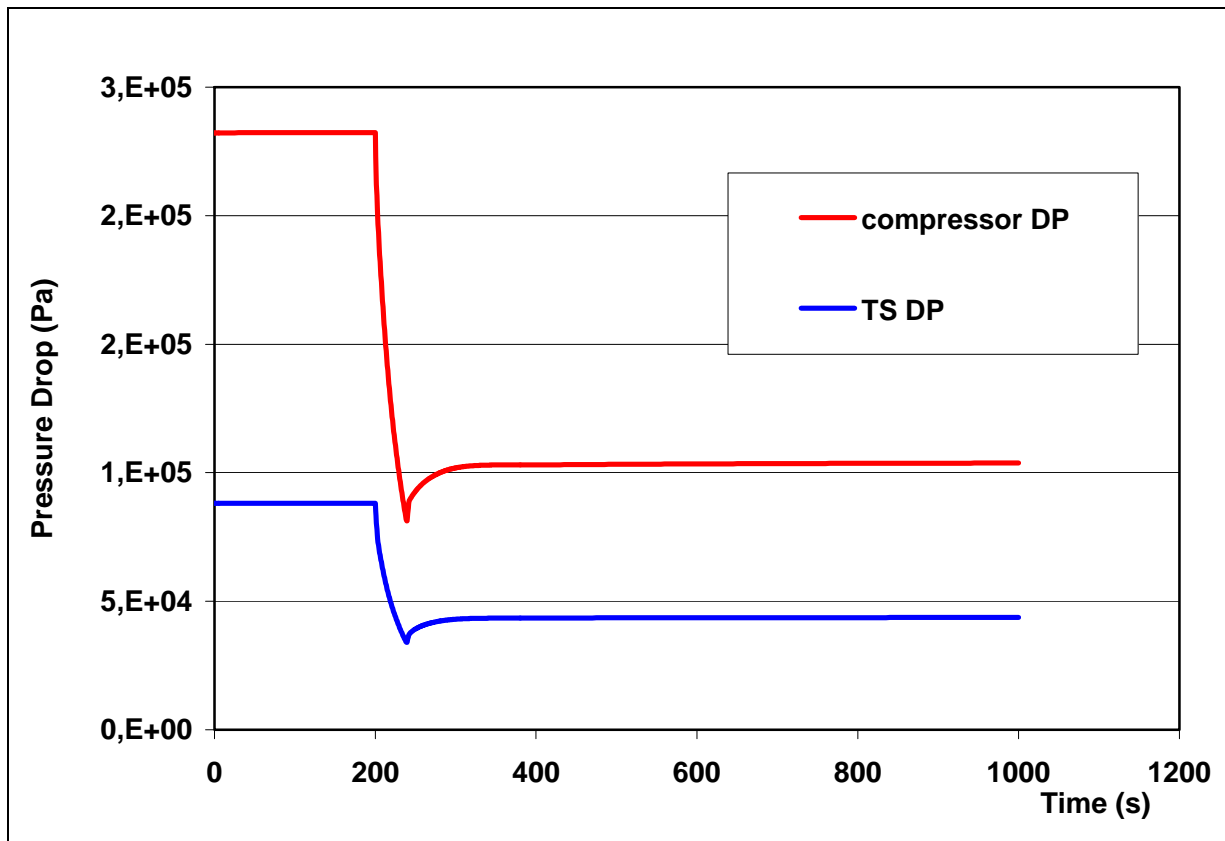



Fig. 4.40 – Loop and TS pressure Drops

 Ricerca Sistema Elettrico	Sigla di identificazione	Rev.	Distrib.	Pag.	di
	NNFISS – LP3 - 002	0	L	45	134

5. Conclusions

Pre-test calculations with RELAP5 code have been carried out to support a new experimental campaign planned on the HE-FUS3 loop with the objective to better characterize the loop implementing new instrumentation as well as to enlarge the experimental data base for the assessment of thermal-hydraulic codes for HTGRs.

To this purpose a start-up procedure by steps and a series of three transients have been simulated with the version Mod3.3 of the RELAP5 code in order to provide a specifications of the initial and boundary conditions to be used in the conduction of the experiments. The results related to the three transients, Loss of Flow Accident (LOFA) driven by the compressor slow-down, Transient of Power (TOP) driven by an increase of the Test Section electrical power and Loss of Coolant Accident (LOCA) caused by the opening of a valve on the expansion tank, are essential to guarantee that the design temperature limits are not reached, thus avoiding the intervention of the protection system and an unexpected stop of the transient.

For the LOCA transient, in particular, some parametric calculations have been performed to dimension a protection valve to be implemented on the break line to prevent too fast depressurization.

 Ricerca Sistema Elettrico	Sigla di identificazione	Rev.	Distrib.	Pag.	di
	NNFISS – LP3 - 002	0	L	46	134

6. References

- [1] G. Dell’Orco, “HE-FUS3 European Helium Cooled Blanket Test Facility for DEMO” Presentation to 1st Meeting on HCPB Blanket Design - Karlsruhe, Germany, 1996.
- [2] A. Tincani, L. Rapezzi, G. Polazzi, M. Querci, S. Panichi, “HE-FUS 3 Experimental Campaign for the Assessment of Thermal-Hydraulic Codes. - Experiment Data Report” ENEA RG-T-R-002, April 2009.
- [3] P. Meloni, M. Polidori “HE-FUS 3 Experimental Campaign for the Assessment of Thermal-Hydraulic Codes. - Post-Test Analysis ” ENEA RT FPN-P9LU-036, April 2009.
- [4] M. Polidori “HE-FUS 3 Experimental Campaign for the Assessment of Thermal-Hydraulic Codes. - Pre-Test Analysis and Test Specifications” ENEA RT FPN-P9LU-015, December 2008.
- [5] “Relap5/Mod 3.3 Code Manual” Information Systems Laboratories, Inc., Document NUREG/CR-5535/
- [6] P. Meloni and M. Casamirra, “Overview of Helium Cooled System Applications with RELAP at ENEA”, Proceedings of ICAPP ’06, Reno, NV USA, 2006
- [7] P. Meloni “HE-FUS3 Facility Nodalization for ATHENA/RELAP code”, ENEA Document CT-SBA-00003, 1998
- [8] M. Polidori “HE-FUS3 Loop: Data Sheets for Code Modelling and Experimental Data for Code Assessment”, ENEA Document FPN – P9L7-001, 2008

APPENDIX A: RELAP5 Input Deck for Steady State Conditions

```

*           HE-FUS3 Input Deck per RELAP5 Mod3.3
*
*
=Helium Loop
*
100 new transnt
*
101 run
*
110 helium
*
*
* time steps                min  mj   re
*
201 2500. 1.e-7   0.01   3   100  5000 5000
*
* -----
* minor edits
* -----
*
* Extended variables:
*
20800001 httemp 360300114 * test section pin 222 mm
20800002 httemp 360300113 * test section pin 222 mm
20800003 httemp 360300314 * test section pin 666 mm
20800004 httemp 360300313 * test section pin 666 mm
20800005 httemp 360300414 * test section pin 888 mm
20800006 httemp 360300413 * test section pin 888 mm
20800007 httemp 360300514 * test section pin 1110 mm
20800008 httemp 360300513 * test section pin 1110 mm
20800009 httemp 360300614 * test section pin 1332 mm
20800010 httemp 360300613 * test section pin 1332 mm
20800011 httemp 360300814 * test section pin 1776 mm
20800012 httemp 360300813 * test section pin 1776 mm
*
*
20800013 httemp 360400114 * test section pin 222 mm
20800014 httemp 360400113 * test section pin 222 mm
20800015 httemp 360400314 * test section pin 666 mm
20800016 httemp 360400313 * test section pin 666 mm
20800017 httemp 360400414 * test section pin 888 mm
20800018 httemp 360400413 * test section pin 888 mm
20800019 httemp 360400514 * test section pin 1110 mm
20800020 httemp 360400513 * test section pin 1110 mm
20800021 httemp 360400614 * test section pin 1332 mm
20800022 httemp 360400613 * test section pin 1332 mm
20800023 httemp 360400814 * test section pin 1776 mm
20800024 httemp 360400813 * test section pin 1776 mm
*
*
20800025 httemp 340301503 * temperatura parete tubo TS lower plenum
20800026 httemp 370200103 * temperatura parete tubo TS lower plenum
*
20800027 httemp 365100121 * temperatura lamierino TS outlet
*

```

20800028 httemp 180100101 * piping wall temp. econ. cold inlet
 20800029 httemp 180100102 * " " "
 *
 20800030 httemp 210100101 * piping wall temp. econ. cold outlet
 20800031 httemp 210100102 * " " "
 *
 20800032 httemp 390100201 * piping wall temp. econ. hot inlet
 20800033 httemp 390100202 * " " "
 *
 20800034 httemp 420100101 * piping wall temp. econ. hot inlet
 20800035 httemp 420100102 * " " "
 *

* minor edits

*

*310 tempg 140010000 * tank
 *311 tempg 180020000 * inlet econom. cold side
 *312 tempg 210010000 * outlet econom. cold side
 *313 tempg 315040000 * outlet by-pass
 *314 tempg 250010000 * out E/3
 *315 tempg 270010000 * out E/2
 *316 tempg 300140000 * out E/3
 *317 tempg 320010000 * inlet TS
 *318 tempg 390020000 * inlet econom. hot side
 *319 tempg 420010000 * outlet econom. hot side
 *320 tempg 480010000 * outlet areotermo
 *321 tempg 120010000 * outlet compressore
 *
 322 mflowj 150000000 * portata totale
 323 mflowj 175000000 * portata resistori
 324 mflowj 172000000 * portata by-pass
 *
 325 cntrlvar 040 * salto pressione compressore
 326 cntrlvar 041 * salto pressione TS
 *
 327 pmphead 600
 328 pmpvel 600
 *
 *
 *338 cntrlvar 011 * potenza risc 1
 *339 cntrlvar 012 * potenza risc 2
 339 cntrlvar 503 * potenza risc 3
 340 cntrlvar 214 * potenza econ. mantello
 341 cntrlvar 215 * potenza econ. tubi
 342 cntrlvar 016 * potenza scambiata aerotermo
 343 cntrlvar 555 * potenza pins
 *
 344 cntrlvar 031 * perdite termiche economiz.
 345 cntrlvar 032 * perdite termiche heaters
 346 cntrlvar 033 * perdite termiche TS
 347 cntrlvar 028 * perdite termiche TS-economizz.
 348 cntrlvar 034 * perdite termiche cold part
 349 cntrlvar 030 * perdite termiche totali
 *
 350 p 140040000
 351 p 365010000
 352 p 480090000

*

*

360 cntrlvar 200
 361 cntrlvar 201
 362 cntrlvar 202
 363 cntrlvar 203
 364 cntrlvar 204
 365 cntrlvar 205
 366 cntrlvar 206
 367 cntrlvar 207
 368 cntrlvar 208
 369 cntrlvar 209

*

370 cntrlvar 210 * test section aver pin 222 mm
 371 cntrlvar 211 * test section aver pin 777 mm
 372 cntrlvar 212 * test section aver pin 1221 mm
 373 cntrlvar 213 * test section aver pin 1776 mm

*

374 cntrlvar 314 * test section hot pin 222 mm
 375 cntrlvar 315 * test section hot pin 777 mm
 376 cntrlvar 216 * test section hot pin 1221 mm
 377 cntrlvar 217 * test section hot pin 1776 mm

*

378 cntrlvar 220 * test section lower plenum wall (aver)
 379 cntrlvar 223 * test section outside wall (max)
 380 cntrlvar 224 * test section lower plenum wall (min)
 381 cntrlvar 221 * test section outside wall
 382 cntrlvar 225 * test section helium outlet

*

383 cntrlvar 230
 384 cntrlvar 231
 385 cntrlvar 232
 386 cntrlvar 233

*

390 mflowj 147000000 * portata rottura
 391 vlvarea 172 * apertura valvola by-pass

*

*350 htmode 400100100
 *351 htmode 400100101
 *352 htmode 400100600
 *353 htmode 400100601
 *354 htmode 400101300
 *355 htmode 400101301
 *356 htmode 400101900
 *357 htmode 400101901

*

*340 httemp 300100105
 *341 httemp 300100205
 *342 httemp 300100305
 *343 httemp 300100405
 *344 httemp 300100505
 *345 httemp 300100605
 *346 httemp 300100705

*

*

*350 htthtc 300100101
 *351 htthtc 300100201
 *352 htthtc 300100301

```

*353 hthtc 300100401
*354 hthtc 300100501
*355 hthtc 300100601
*356 hthtc 300100701
*
*-----
* trips
*-----
*
* pump trip for decay and regulation
*
501 time 0 ge null 0 1.e6 n * pu-trip
*
* pump regulation
510 time 0 ge null 0 50. 1 * regulation on
511 time 0 le null 0 99999. 1 * regulation off
610 510 and 511 n *
*
*
515 time 0 ge null 0 500. 1 * PRZ closure trip
601 -515 and -515 n * PRZ opening trip
*
*-----
* FV-213 valve regulation
*
517 time 0 le null 0 99999. 1 *trip closure fv234
603 -517 and -517 n *trip opening fv234
*
516 time 0 ge null 0 99999. 1 *trip opening fv213
616 -517 and -517 n *trip closure fv213
*
*-----
* Regulation of valve FV-234 (by-pass economizer)
*
536 cntrlvar 59 ge null 0 0.5 n -1.
537 cntrlvar 58 ge null 0 0.5 n -1.
*
* Regulation off
*
538 time 0 ge null 0 999999. 1 -1. * regolazione off
640 538 and 538 n
*
*-----
* Regulation of Valve FV235 (by-pass of loop hot part)
*
525 time 0 ge null 0 99999. n * opening trip
526 time 0 le null 0 99999. n * closure trip
625 525 and 526 n
626 -526 and -526 n
*
*
* Regulation of Valve for break opening
*
555 time 0 ge null 0 99999. 1 -1. *trip apertura break
556 p 140040000 le null 0 25.e5 1 * trip chiusura break
655 555 and 556 n
656 -556 and -556 n
*

```

```

*-----
*
590 time 0 ge null 0 500. 1 * end of transient
600 590 * end of programm
*
*-----
*
* Hydraulic components
*-----
*
* Tubazione P (Compressore-Serbatoio) orizzontale pgA7-15
* L=1. m, A=0.00216 m2, Didr= 0.052m
*
1200000 ptubo pipe
* partizioni
1200001 2
* sez.(m 2) elemento
1200101 0.002163 2
* lung.(m) elem.
1200301 0.5 2
* vol(m 3) elem.
1200401 0. 2
* azimut elem.
1200501 120. 2
* ang.vertic elem.
1200601 0. 2
* rugos(m) Didr(m) elem.
1200801 4.e-5 0.052 2
* Kdir Kinvr giunzione
1200901 3. 3. 1
* tlpvbfef elem.
1201001 00000 2
* efvcahs giunz.
1201101 001000 1
* ebt P(Pa) T(K) stato ? ? elem.
1201201 004 5.1e6 361.16 0.0 0. 0. 2
* 0:(m/s) 1:(kg/s)
1201300 1
* condizioni iniziali
* mliq mgas ! giunz.
1201301 0. .225 0. 1
*-----
* Sezione di imbocco Tubo P Serbatoio, Kf=1. Kr=0.5 pgA7-11
*
1300000 jun2 sngljun
* da a sez.giun(m 2) Kf Kr efvcahs
1300101 120010000 140000000 0. 1. 0.5 001100
* (kg/s) mliq mgas !
1300201 1 0. .225 0.
*-----
* Serbatoio verticale pgA7-15
* V=3 m3, Didr=0.710 m, L=4.615 m, A=0.650 m2
*
1400000 vess pipe
* partizioni
1400001 5
* sez.(m 2) elemento
1400101 0.650 5
* lung.(m) elem.
1400301 0.923 5

```

```

*      vol(m 3)   elem.
1400401 0.        5
*      azimuth   elem.
1400501 0.        5
*      ang.vertic elem.
1400601 90.        5
*      rugos(m)  Didr(m) elem.
1400801 4.e-5       0.710  5
*      Kdir      Kinvr   giunzione
1400901 0.        0.      4
*      tlpvbfef elem.
1401001 00000      5
*      efvcahs   giunz.
1401101 001000     4
*      ebt P(Pa) T(K) stato ? ? elem.
1401201 004 5.1e6 361.16 0.0 0. 0. 5
*      0:(m/s) 1:(kg/s)
1401300 1
*      mliq mgas ! giunz.
1401301 0. .225 0. 4

```

```

*-----
*      Pressurizzatore      P=4.9 MPa                                pgA7-6
*

```

```

1430000 prescomp tmdpvolf
*      sez(m 2) lung(m) vol(m 3) azim ang.vert elev(m) rug(m) Didr(m)
tlpvbfef
1430101 100.      1.      0.      0. 0.      0.      0.      0.
00000
*      ebt
1430200 004
*      ? P(Pa) T(K)
1430201 0.      5.0e6 361. 0.0
1430202 50.      5.0e6 361. 0.0
1430203 9999.     5.0e6 361. 0.0

```

```

*-----
*      Valvola Regolazione Pressione S=0.025 m2                                pgA7-
41
*

```

```

1450000 prsvalv valve
*      da      a      sez.giu(m 2) Kdir Kinv efvcahs
1450101 143000000 140010000 0.025      0. 0.      001000
*      condizioni iniziali
*      (kg/s) mliq mgas !
1450201 1      0. .0 0.
*      tipo valvola
1450300 trpvlf
*      apritrip
1450301 601

```

```

*-----
*      Valvola Simulazione Rottuta
*

```

```

1470000 bypvlf valve
*      da      a      sez.giu(m 2) Kdir Kinv efvcahs
1470101 140010000 148000000 1.114e-3 0. 0.      000000
*      condizioni iniziali
*      (kg/s) mliq mgas !

```

```

1470201 1      0.  0.01  0.
*      tipo valvola
1470300 mtrvly
*      apritrip chiuditrip vel.cambio pos.iniz.
1470301 655    656      .33333  0.0
*      pos.normaliz CSUBVdir CSUBVinv
1470400 1.    0.08
*
1470401 0.      0.      0.
1470402 0.1    19.0    19.0
1470403 0.3    38.0    38.0
1470404 0.4    55.0    55.0
1470405 0.5    81.0    81.0
1470406 0.6    115.0   115.0
1470407 0.7    156.0   156.0
1470408 0.8    207.0   207.0
1470409 0.9    265.0   265.0
1470410 0.9    331.0   331.0
*
*-----
* Linea di scarico
*
1480000 dcline pipe
*      partizioni
1480001 6
*      sez.(m 2) elemento
1480101 1.142e-3 2
1480102 1.903e-3 6
*      lung.(m) elem.
1480301 0.5    6
*      vol(m 3) elem.
1480401 0.      6
*      azimuth elem.
1480501 0.      6
*      ang.vertic elem.
1480601 0.      6
*      rugos(m) Didr(m) elem.
1480801 4.e-5   0.0381  2
1480802 4.e-5   0.0493  6
*      Kdir      Kinvr   giunzione
1480901 0.      0.      1
1480902 1.      0.5    2
1480903 0.      0.      3
1480904 7.      7.      4
1480905 0.      0.      5
*      tlpvbfef elem.
1481001 00000 6
*      efvcahs giunz.
1481101 00000 5
*      ebt P(Pa) T(K) stato ? ? elem.
1481201 004 1.e5 361.16 0.0 0. 0. 6
*      0:(m/s) 1:(kg/s)
1481300 1
*      condizioni iniziali
*      mliq mgas ! giunz.
1481301 0.    .0 0. 5
*
*-----
*      valvola manuale da 2 inc.

```

```

*
1490000 vlvman sngljun
*      da      a      sez.giun(m 2) Kf  Kr   efvcahs
1490101 148010000 146000000 0.      2.6  2.6  000000
*      (kg/s) mliq mgas !
1490201 1      0.0  0.0  0.0
*
*-----
*      Scarico in atmosfera
*
1460000 prescomp tmdpvvol
*      sez(m 2) lung(m) vol(m 3) azim ang.vert elev(m) rug(m) Didr(m)
tlpvbfef
1460101 100.    1.      0.      0.  0.      0.      0.      0.
00000
*      ebt
1460200 004
*      ?      P(Pa) T(K)
1460201 0.      1.0e5  361.  0.0
1460202 50.      1.0e5  361.  0.0
1460203 9999.    1.0e5  361.  0.0
*
*-----
*      Sezione collegamento Serbatoioo-Tubazione D Kf=0.5 Kr=1.   pgA7-11
*
1500000 jun3 sngljun
*      da      a      sez.giun(m 2) Kf  Kr   efvcahs
1500101 140010000 160000000 0.      0.5  1.    001100
*      (kg/s) mliq mgas !
1500201 1      0.      .225  0.
*
*-----
*      Tubo D prima parte
*      (due curve 900 K=0.5 + restringimento e flangia tarata FT 212 K=8.7)
*      Ltot=7.919 m
*      !!! k ridotto del 90% K=7.83
*      A=0.00737-0.00144-0.00737      Didr=0.097-0.043-0.097
*
1600000 dtubo pipe
*      partizioni
1600001 9
*      sez.(m 2) elemento
1600101 0.007371  5
1600102 0.001444  7
1600103 0.007371  9
*      lung.(m) elem.
1600301 0.447      1
1600302 0.869      4
1600303 0.973      9
*      vol(m 3) elem.
1600401 0.      9
*      azimut elem.
1600501 180.      1
1600502 0.      4
1600503 270.      9
*      ang.vertic elem.
1600601 0.      1
1600602 -90.      4
1600603 0.      9
*      rugos(m) Didr(m) elem.

```

```

1600801 4.e-5      0.097  5
1600802 4.e-5      0.043  7
1600803 4.e-5      0.097  9
*      Kdir      Kinvr   giunzione
1600901 0.5         0.5    1
1600902 0.5         0.5    5
1600903 8.7         8.7    6
1600904 0.          0.     8
*      tlpvbf   elem.
1601001 00000      9
*      efvcahs  giunz.
1601101 001000    8
*      ebt  P(Pa) T(K) stato ? ? elem.
1601201 004 5.1e6 361.16 0.0 0. 0. 9
*      0:(m/s) 1:(kg/s)
1601300 1
*      mliq mgas ! giunz.
1601301 0. .225 0. 8
*-----
* Linea by-pass della parte calda del loop
*
4990000 closure branch
*
4990001 1 1
*      sez(m 2) lung(m) vol(m 3) azim incli elev(m) rug(m) Didr(m)
tlpvbf
4990101 4.0579e-3 1.636 0. 0. -90. -1.636 4.e-5 0.072
00000
*      ebt  P(Pa) T(K)
4990200 004 5.1e6 361.16 0.0
*      da a sez.giu(m 2) Kdir Kinv efvcahs
4991101 160010000 499000000 0. 0. 0. 001000
*      condizioni iniziali
*      mliq mgas !
4991201 0. 0.01 0.
*-----
* Valvola 235
*      Valvola di regolazione (Cvmax=331)
*      Cv utilizzato=221 per riprodurre pressure drops (si
ipotizza
*      non completa apertura)
*
5100000 bypv12 valve
*      da a sez.giu(m 2) Kdir Kinv efvcahs
5100101 499010000 520000000 4.0579e-3 0. 0. 001000
*      condizioni iniziali
*      (kg/s) mliq mgas !
5100201 1 0. 0.01 0.
*      tipo valvola
5100300 mtrvlv
*      apritrip chiuditrip vel.cambio pos.iniz.
5100301 625 626 .25 0.0001
*      pos.normaliz CSUBVdir CSUBVinv
5100400 1. 0.08
*
5100401 0. 0. 0.
5100402 0.08 9.965 9.965
5100403 0.11 15.06 15.06
5100404 0.16 21.17 21.17

```

```

5100405 0.3          25.55    25.55
5100406 0.4          37.45    37.45
5100407 0.47         50.67    50.67
5100408 0.5          55.06    55.06
5100409 0.58         70.68    70.68
5100410 0.6          77.79    77.79
5100411 0.7          105.68   105.68
5100412 0.8          140.20   140.20
5100413 0.9          179.33   179.33
5100414 1.           224.     224.

```

*

* Tubo bypass I seconda parte verticale L=2.665 m, A=0.007371 m2,

*

*

5200000 itubo2 pipe

* partizioni

5200001 2

* sez.(m 2) elemento

5200101 4.0579e-3 2

* lung.(m) elem.

5200301 0.5 2

* vol(m 3) elem.

5200401 0. 2

* azimut elem.

5200501 0. 2

* ang.vertic elem.

5200601 0. 2

* rugos(m) Didr(m) elem.

5200801 4.e-5 0.072 2

* Kdir Kinvr giunzione

5200901 0.0 0.0 1

* tlpvbfefe elem.

5201001 00000 2

* efvcahs giunz.

5201101 001000 1

* ebt P(Pa) T(K) stato ? ? elem.

5201201 004 4.9e6 400.16 0.0 0. 0. 2

* 0:(m/s) 1:(kg/s)

5201300 1

* mliq mgas ! giunz.

5201301 0. 0. 0.01 1

*

5210000 closure branch

*

5210001 2 1

* sez(m 2) lung(m) vol(m 3) azim incli elev(m) rug(m) Didr(m) tlpvbfefe

5210101 4.0579e-3 0.2 0. 0. 0. 0. 4.e-5 0.072 00000

* ebt P(Pa) T(K)

5210200 004 4.9e6 400.16 0.0

* da a sez.giu(m 2) Kdir Kinv efvcahs

5211101 520010000 521000000 0. 0. 0. 001000

5212101 521010000 440000000 0. 0. 0. 001000

* condizioni iniziali

* mliq mgas !

5211201 0. 0.01 0.

5212201 0. 0.01 0.

*

```

*-----
* Ricomincia la linea principale
*-----
*   Tubazione D parte seconda                                pgA7-27
* (innesco con curva 900 K=0.5 + tee bypass TS fredda K=1.0, curva 900
*   K=0.5 + tee per by pass ciclaggi K=1, Innesco tubazione I K=1)
* L=2.902 m, A=0.007371 m2
*
1700000 Hltubo branch
*   tipo? (kg/s)
1700001 3      1
*   sez.(m 2) lung(m) vol(m 3) azim incli elev(m) rug(m) Didr(m) tlpvbf
1700101 0.007371 2.902 0.      0.  90.  2.902  4.e-5  0.097  00000
*   ebt  P(Pa) T(K)
1700200 004  5.1e6 361.16 0.0
*   da      a      sez.giu(m 2) Kdir  Kinv  efvcahs
1701101 160010000 170000000 0.      1.5  1.5  001000
1702101 170010000 173000000 0.      1.5  1.5  001000
1703101 170010000 171000000 0.      1.0  1.0  001000
*   condizioni iniziali
*   mliq mgas  !
1701201 0.      .225 0.
1702201 0.      .225 0.
1703201 0.      0. 0.
*-----
* Ramo by-pass dell'economizzatore
*-----
*   Tubo bypass I prima parte orizz. L=2.5064 m, A=0.007371 m2, Didr=0.097
*
1710000 itubol pipe
*   partizioni
1710001 4
*   sez.(m 2) elemento
1710101 0.007371 4
*   lung.(m) elem.
1710301 0.6266 4
*   vol(m 3) elem.
1710401 0.      4
*   azimut elem.
1710501 90.      4
*   ang.vertic elem.
1710601 0.      4
*   rugos(m) Didr(m) elem.
1710801 4.e-5  0.097 4
*   Kdir  Kinvr  giunzione
1710901 0.0  0.0  3
*   tlpvbf elem.
1711001 00000 4
*   efvcahs giunz.
1711101 001000 3
*   ebt  P(Pa) T(K) stato ? ? elem.
1711201 004  5.1e6 361.16 0.0  0. 0.  4
*   0:(m/s) 1:(kg/s)
1711300 1
*   mliq mgas  ! giunz.
1711301 0.  0.  0.  3
**-----
*   Valvola Fv234
*   valvola di regolazione (Cvmax=331)

```

* Cv utilizzato=221 per riprodurre pressure drops (si ipotizza non completa apertura) si è riscaldato tutto sul valore finale con rapporto .677

* 1720000 bypvl2 valve
 * da a sez.giu(m 2) Kdir Kinv efvcahs
 1720101 171010000 315000000 4.0579e-3 0. 0. 001000

* condizioni iniziali
 * (kg/s) mliq mgas !
 1720201 1 0. 0. 0.

* tipo valvola
 1720300 srvvlv
 * control

1720301 156
 * pos.normaliz CSUBVdir CSUBVinv
 1720400 1. 0.08

*
 1720401 0. 0. 0.
 1720402 0.08 9.965 9.965
 1720403 0.11 15.06 15.06
 1720404 0.16 21.17 21.17
 1720405 0.3 25.55 25.55
 1720406 0.4 37.45 37.45
 1720407 0.47 50.67 50.67
 1720408 0.5 55.06 55.06
 1720409 0.58 70.68 70.68
 1720410 0.6 77.79 77.79
 1720411 0.7 105.68 105.68
 1720412 0.8 140.20 140.20
 1720413 0.9 179.33 179.33
 1720414 1. 224. 224.

*
 *-----
 *-----
 * Ricomincia la linea principale
 *-----

* Tubo D parte terza L=650 mm,
 * restringimento A=0.007371-4.0579e-3, Didr=0.097-0.072

*
 1730000 H2tubo pipe
 * partizioni
 1730001 2
 * sez.(m 2) elemento
 1730101 0.007371 1
 1730102 4.0579e-3 2
 * lung.(m) elem.
 1730301 0.600 1
 1730302 0.050 2
 * vol(m 3) elem.
 1730401 0. 2
 * azimut elem.
 1730501 360. 2
 * ang.vertic elem.
 1730601 0. 2
 * rugos(m) Didr(m) elem.
 1730801 4.e-5 0.097 1
 1730802 4.e-5 0.072 2
 * Kdir Kinvr giunzione

```

1730901 0.75      1.0      1
*      tlpvbf     elem.
1731001 00000      2
*      efvcahs   giunz.
1731101 001000     1
*      ebt P(Pa) T(K) stato ? ? elem.
1731201 004 5.0e6 361.16 0.0 0. 0. 2
*      0:(m/s) 1:(kg/s)
1731300 1
*      mliq mgas ! giunz.
1731301 0. .225 0. 1
*-----
*
*      Valvola di regolazione (Cvmax=331)
*      Cv utilizzato=221 per riprodurre pressure drops (si
ipotizza
*      non completa apertura)
*
1750000 bypv11 valve
*      da a sez.giu(m 2) Kdir Kinv efvcah
1750101 173010000 180000000 4.0579e-3 0. 0. 001000
*      condizioni iniziali
*      (kg/s) mliq mgas !
1750201 1 0. 0.225 0.
*      tipo valvola
1750300 mtrv1v
*      apritrip chiuditrip vel.cambio pos.iniz.
1750301 516 616 .033333 1.0
*      pos.normaliz CSUBVdir CSUBVinv
1750400 1. 0.08
1750401 0. 0. 0.
1750402 0.08 14.72 14.72
1750403 0.11 22.24 22.24
1750404 0.16 31.28 31.28
1750405 0.3 37.74 37.74
1750406 0.4 55.32 55.32
1750407 0.47 74.85 74.85
1750408 0.5 81.33 81.33
1750409 0.58 104.4 104.4
1750410 0.6 114.9 114.9
1750411 0.7 156.1 156.1
1750412 0.8 207.1 207.1
1750413 0.9 264.9 264.9
1750414 1. 206. 206.
*-----
*      Tubo D parte quarta L=650 mm,
*      allargamento A=4.0579e-3-0.007371, Didr=0.072-0.097
*
1800000 H3tubo pipe
*      partizioni
1800001 2
*      sez.(m 2) elemento
1800101 4.0579e-3 1
1800102 0.00737 2
*      lung.(m) elem.
1800301 0.050 1
1800302 0.600 2
*      vol(m 3) elem.
1800401 0. 2

```



```

*      azimuth      elem.
1800501 360.        2
*      ang.vertic  elem.
1800601 0.            2
*      rugos(m)    Didr(m) elem.
1800801 4.e-5          0.072  1
1800802 4.e-5          0.097  2
*      Kdir        Kinvr   giunzione
1800901 1.0           0.75   1
*      tlpvbf     elem.
1801001 00000         2
*      efvcahs    giunz.
1801101 001000        1
*      ebt  P(Pa) T(K) stato ? ? elem.
1801201 004 5.0e6 361.16 0.0 0. 0. 2
*      0:(m/s) 1:(kg/s)
1801300 1
*      mliq mgas ! giunz.
1801301 0. .225 0. 1
*-----
* Giunzione di imbocco economizzatore Kf=1.0 Kr=0.5
*
1850000 ingserb  sngljun
*      da      a      sez.giun(m 2) Kf Kr efvcahs
1850101 180010000 200000000 4.0579e-3 1.0 0.5 001100
*      (kg/s) mliq mgas !
1850201 1      0. .225 0.
*-----
*-----
* Economizzatore lato mantello L=5000 mm, A=0.0288 m2, Didr=0.01818 m
* Modifica Ansaldo !!! pressure drop coeff. associati ai setti
k=8
2000000 economl pipe
*      partizioni
2000001 38
*      sez.(m 2) elemento
2000101 0.018 38 * 0.0202014 * 0.0288
*      lung.(m) elem.
2000301 0.1315 38
*      vol(m 3) elem.
2000401 0. 38
*      azimuth elem.
2000501 0. 38
*      ang.vertic elem.
2000601 90. 38
*      rugos(m) Didr(m) elem.
2000801 4.e-5 0.01275 38 * 0.01818
*      Kdir Kinvr giunzione
2000901 4. 4. 37
*      tlpvbf     elem.
2001001 00000 38
*      efvcahs    giunz.
2001101 001000 37
*      ebt  P(Pa) T(K) stato ? ? elem.
2001201 004 5.e6 345.16 0.0 0. 0. 1
2001202 004 5.e6 360.16 0.0 0. 0. 4
2001203 004 5.e6 375.16 0.0 0. 0. 6
2001204 004 5.e6 390.16 0.0 0. 0. 8
2001205 004 5.e6 405.16 0.0 0. 0. 10

```

```

2001206 004 5.e6 420.16 0.0 0. 0. 12
2001207 004 5.e6 435.16 0.0 0. 0. 14
2001208 004 5.e6 460.16 0.0 0. 0. 16
2001209 004 5.e6 475.16 0.0 0. 0. 18
2001210 004 5.e6 490.16 0.0 0. 0. 20
2001211 004 5.e6 505.16 0.0 0. 0. 22
2001212 004 5.e6 520.16 0.0 0. 0. 24
2001213 004 5.e6 535.16 0.0 0. 0. 26
2001214 004 5.e6 560.16 0.0 0. 0. 28
2001215 004 5.e6 575.16 0.0 0. 0. 30
2001216 004 5.e6 590.16 0.0 0. 0. 32
2001217 004 5.e6 605.16 0.0 0. 0. 34
2001218 004 5.e6 605.16 0.0 0. 0. 36
2001219 004 5.e6 605.16 0.0 0. 0. 38
* 0:(m/s) 1:(kg/s)
2001300 1
* mliq mgas ! giunz.
2001301 0. .225 0. 37
*-----
*-----
* Tubazione E parte prima (giunzione uscita economizzatore K=0.5
* + tee valvola HV251 K=1.5)L=0.626 m, A=0.007371 m2, Didr=0.097 m
*
2100000 eltubo branch
* tipo? (kg/s)
2100001 2 1
* sez(m 2) lung(m) vol(m 3) azim incli elev(m) rug(m) Didr(m) tlpvbfe
2100101 0.007371 0.626 0. 90. 0. 0. 4.e-5 0.097 00000
* ebt P(Pa) T(K)
2100200 004 5.0e6 605.16 0.0
* da a sez.giu(m 2) Kdir Kinv efvcahs
2101101 200010000 210000000 0. 0.5 1. 001100
2102101 210010000 220000000 0. 1.5 1.5 001000
* condizioni iniziali
* mliq mgas !
2101201 0. .225 0.
2102201 0. .225 0.
*-----
* Tubazione E parte seconda (Parte verticale)
* L=2.332 m, A=0.007371 m2, Didr=0.097 m
*
2200000 e2tubo pipe
* partizioni
2200001 2
* sez.(m 2) elemento
2200101 0.007371 2
* lung.(m) elem.
2200301 1.166 2
* vol(m 3) elem.
2200401 0. 2
* azimut elem.
2200501 0. 2
* ang.vertic elem.
2200601 -90. 2
* rugos(m) Didr(m) elem.
2200801 4.e-5 0.097 2
* Kdir Kinvr giunzione
2200901 0. 0. 1
* tlpvbfe elem.

```

```

2201001 00000      2
*      efvcahs      giunz.
2201101 001000     1
*      ebt P(Pa) T(K) stato ? ? elem.
2201201 004 5.0e6 605.16 0.0 0.0. 2
*      0:(m/s) 1:(kg/s)
2201300 1
*      mliq mgas ! giunz.
2201301 0. .225 0. 1
*-----
* Valvola HV250 (csub cv=0.509 k=3.85 A=0.007371) + tee k=1.5
*      Ansaldo coeff. 100%
2250000 HV250 sngljun
*      da a sez.giun(m 2) Kf Kr efvcahs
2250101 220010000 230000000 0.007371 5.35 5.35 001000
*      (kg/s) mliq mgas !
2250201 1 0. .225 0.
*-----
* Tubazione E parte terza con 2 curve 900 (k=1.0)
* + imbocco riscaldatore 1 (k=1.0)
* L=2.084 m, A=0.007371 m2, Didr=0.097 m
*
2300000 e3tubo branch
*      tipo? (kg/s)
2300001 1 1
*      sez(m 2) lung(m) vol(m 3) azim incli elev(m) rug(m) Didr(m) tlpvbfe
2300101 0.007371 2.084 0. 180. 0. 0. 4.e-5 0.097 00000
*      ebt P(Pa) T(K)
2300200 004 5.0e6 605.16 0.0
*      da a sez.giu(m 2) Kdir Kinv efvcahs
2301101 230010000 240000000 0. 2.0 1.5 001100
*2301101 220010000 230000000 0. 2.0 2.0 001000
*      condizioni iniziali
*      mliq mgas !
2301201 0. .225 0.
*2302201 0. 0.35 0.
*-----
*
* Riscaldatore 1
*
* Ltot=2230 mm, Lunghezza scaldante L=1800 mm, A=0.0572-0.0466 m2
* Didr=0.066 m
* Numero diaframmi 12, perdite di carico dovute a diaframmi K=12.0
* Ptermica=70 kwatt
*
*
2400000 e219/3 pipe
*      partizioni
2400001 14
*      sez.(m 2) elemento
2400101 0.0572 1
2400102 0.0466 14
*      lung.(m) elem.
2400301 0.130 1
2400302 0.16363 12
2400303 0.150 14
*      vol(m 3) elem.
2400401 0. 14
*      azimut elem.
2400501 0. 14

```

```

*      ang.vertic elem.
2400601 90.      14
*      rugos(m)   Didr(m) elem.
2400801 4.e-5     0.0    1
2400802 4.e-5     0.066  14
*      Kdir      Kinvr   giunzione
2400901 0.0      0.0    1
2400902 12.      12.    13
*      tlpvbf   elem.
2401001 00000    14
*      efvcahs  giunz.
2401101 001000   13
*      ebt P(Pa) T(K) stato ? ? elem.
2401201 004 5.0e6 590.16 0.0 0. 0. 14
*      0:(m/s) 1:(kg/s)
2401300 1
*      mliq mgas ! giunz.
2401301 0.      .225  0. 13
*-----
* Tubazione F parte prima
*
* L=0.528 m, A=0.008012 m2, Didr=0.101 m
*
2500000 fltubo branch
*      tipo? (kg/s)
2500001 2      1
*      sez(m 2) lung(m) vol(m 3) azim incli elev(m) rug(m) Didr(m) tlpvbf
2500101 0.008012 0.528 0.      90. 0. 0.      4.e-5 0.101 00000
*      ebt P(Pa) T(K)
2500200 004 5.0e6 590.16 0.0
*      da      a      sez.giu(m 2) Kdir Kinv efvcahs
2501101 240010000 250000000 0.      0.5 1.0 001100
2502101 250010000 260000000 0.      1.0 0.5 001100
*      condizioni iniziali
*      mliq mgas !
2501201 0.      .225  0.
2502201 0.      .225  0.
*-----
* Riscaldatore 2
*
* Ltot=2230 mm, Lunghezza scaldante L=1800 mm, A=0.0572-0.0466 m2,
* Didr=0.066 m* Numero diaframmi 12 perdite di carico dovute a diaframmi
K=12
* K=2.0 Ptermica=70 kwatt
*
2600000 e219/2 pipe
*      partizioni
2600001 14
*      sez.(m 2) elemento
2600101 0.0466 13
2600102 0.0572 14
*      lung.(m) elem.
2600301 0.150 2
2600302 0.16363 13
2600303 0.130 14
*      vol(m 3) elem.
2600401 0.      14
*      azimut elem.
2600501 0.      14

```

```

*      ang.vertic elem.
2600601 -90.      14
*      rugos(m)   Didr(m) elem.
2600801 4.e-5     0.066 13
2600802 4.e-5     0.0    14
*      Kdir      Kinvr  giunzione
2600901 12.      12.    12
2600902 0.0      0.0    13
*      tlpvbf     elem.
2601001 00000     14
*      efvcahs    giunz.
2601101 001000     13
*      ebt P(Pa) T(K) stato ? ? elem.
2601201 004 5.0e6 620.16 0.0 0. 0. 14
*      0:(m/s) 1:(kg/s)
2601300 1
*      mliq mgas ! giunz.
2601301 0.    .225 0. 13
*-----
* Tubazione F parte seconda
* (sbocco riscaldatore K=0.5 + tee K=1.5 + curva 900 K=0.5)
* L=0.933 m, A=0.01205 m2, Didr=0.124 m
*
2700000 f2tubo branch
*      tipo? (kg/s)
2700001 1      1
*      sez(m 2) lung(m) vol(m 3) azim incli elev(m) rug(m) Didr(m) tlpvbf
2700101 0.01205 0.933 0.      90. 0. 0.      4.e-5 0.124 00000
*      ebt P(Pa) T(K)
2700200 004 5.0e6 620.16 0.0
*      da      a      sez.giu(m 2) Kdir  Kinv efvcahs
2701101 260010000 270000000 0.      2.5 3.0 001100
*2702101 270010000 280000000 0.      0.5 0.5 001000
*      condizioni iniziali
*      mliq mgas !
2701201 0.    .225 0.
*2702201 0.    0.35 0.
*-----
*
* Valvola HV252 cv=0.509 k=3.85
*      coeff. al 100%
*
2750000 HV252 sngljun
*      da      a      sez.giun(m 2) Kf  Kr  efvcahs
2750101 270010000 280000000 0.0      3.85 3.85 001000
*      (kg/s) mliq mgas !
2750201 1      0.    .225 0.
*-----
* Tubazione F parte terza (verticale)
*
* L=2.23 m, A=0.01205 m2, Didr=0.124 m
*
2800000 f3tubo pipe
*      partizioni
2800001 2
*      sez.(m 2) elemento
2800101 0.01205 2
*      lung.(m) elem.
2800301 1.115 2

```

```

*      vol(m 3)   elem.
2800401 0.        2
*      azimuth   elem.
2800501 0.        2
*      ang.vertic elem.
2800601 90.        2
*      rugos(m)  Didr(m) elem.
2800801 4.e-5        0.124  2
*      Kdir      Kinvr   giunzione
2800901 0.          0.      1
*      tlpvbfe   elem.
2801001 00000      2
*      efvcahs   giunz.
2801101 001000    1
*      ebt P(Pa) T(K) stato ? ? elem.
2801201 004 5.0e6 620.16 0.0 0. 0. 2
*      0:(m/s) 1:(kg/s)
2801300 1
*      mliq mgas !   giunz.
2801301 0.    .225  0.  1
*-----
* Tubazione F parte quarta Orizzontale
* (tee K=1.5 + inbocco riscaldatore 3 K=1.0)
* L=0.528 m, A=0.01205 m2, Didr=0.124 m
*
2900000 f4tubo branch
*      tipo? (kg/s)
2900001 2      1
*      sez(m 2) lung(m) vol(m 3) azim incli elev(m) rug(m) Didr(m) tlpvbfe
2900101 0.01205 0.528 0.      90. 0.  0.      4.e-5 0.124 00000
*      ebt P(Pa) T(K)
2900200 004 4.9e6 620.16 0.0
*      da      a      sez.giu(m 2) Kdir Kinv efvcahs
2901101 280010000 290000000 0.      1.5 1.5 001000
2902101 290010000 300000000 0.      1.0 0.5 001100
*      condizioni iniziali
*      mliq mgas !
2901201 0.    .225  0.
2902201 0.    .225  0.
*-----
* Riscaldatore 3
*
* Ltot=2230 mm, Lunghezza scaldante L=1800 mm,
* A=0.0572-0.0466 m2, Didr=0.066 m
* Numero diaframmi 12,
* Ptermica=70 kwatt, coeff. associati ai diaframmi k=12
*
3000000 e219/1 pipe
*      partizioni
3000001 14
*      sez.(m 2) elemento
3000101 0.0466 13
3000102 0.0572 14
*      lung.(m) elem.
3000301 0.150  2
3000302 0.16363 13
3000303 0.130  14
*      vol(m 3) elem.
3000401 0.      14

```

```

*      azimut      elem.
3000501 0.          14
*      ang.vertic elem.
3000601 -90.          14
*      rugos(m)   Didr(m) elem.
3000801 4.e-5         0.066 13
3000802 4.e-5         0.0    14
*      Kdir       Kinvr   giunzione
3000901 12.          12.    12
3000902 0.0          0.0    13
*      tlpvbf     elem.
3001001 00000        14
*      efvcahs   giunz.
3001101 001000       13
*      ebt P(Pa) T(K) stato ? ? elem.
3001201 004 4.9e6 653.16 0.0 0.0. 14
*      0:(m/s) 1:(kg/s)
3001300 1
*      mliq mgas !   giunz.
3001301 0. .225 0. 13
*-----
* Tubazione G parte prima
* (Sbocco risc. 3 K=0.5 + curva 900 K=0.5 + tee K=1.5 + curva 900 K=0.5)
* L=1.01 m, A=0.01168 m2, Didr=0.122 m
*
3100000 gltubo branch
*      tipo? (kg/s)
3100001 3 1
*      sez(m 2) lung(m) vol(m 3) azim incli elev(m) rug(m) Didr(m) tlpvbf
3100101 0.01168 1.01 0. 0. 0. 0. 4.e-5 0.122 00000
*      ebt P(Pa) T(K)
3100200 004 4.9e6 653.16 0.0
*      da a sez.giu(m 2) Kdir Kinv efvcahs
3101101 300010000 310000000 0. 1.0 1.5 001100
3102101 310010000 320000000 0. 2.0 2.0 001000
3103101 315010000 310010000 0. 1.5 1.5 001000
*      condizioni iniziali
*      mliq mgas !
3101201 0. .225 0.
3102201 0. .225 0.
3103201 0. 0. 0.
*-----
* Tubo bypass I seconda parte verticale L=2.665 m, A=0.007371 m2,
* Didr=0.097 m
*
3150000 itubo2 pipe
*      partizioni
3150001 4
*      sez.(m 2) elemento
3150101 0.007371 4
*      lung.(m) elem.
3150301 0.66625 4
*      vol(m 3) elem.
3150401 0. 4
*      azimut elem.
3150501 0. 4
*      ang.vertic elem.
3150601 90. 4
*      rugos(m) Didr(m) elem.

```

```

3150801 4.e-5      0.097   4
*      Kdir      Kinvr   giunzione
3150901 0.0          0.0     3
*      tlpvbfe   elem.
3151001 00000        4
*      efvcahs   giunz.
3151101 001000       3
*      ebt P(Pa) T(K) stato ? ? elem.
3151201 004 4.9e6 650.16 0.0 0. 0. 4
*      0:(m/s) 1:(kg/s)
3151300 1
*      mliq mgas ! giunz.
3151301 0. 0. 0. 3
*-----
* Tubo G seconda parte (parte verticale + curva 900 K=0.5 + parte
orizzontale)
*
* L=4.284 m, A=0.01168 m2, Didr=0.122 m
*
3200000 g2tubo pipe
*      partizioni
3200001 4
*      sez.(m 2) elemento
3200101 0.01168     4
*      lung.(m) elem.
3200301 1.115       2
3200302 1.027       4
*      vol(m 3) elem.
3200401 0.          4
*      azimuth elem.
3200501 0.          2
3200502 0.          4
*      ang.vertic elem.
3200601 90.         2
3200602 0.          4
*      rugos(m) Didr(m) elem.
3200801 4.e-5      0.122   4
*      Kdir      Kinvr   giunzione
3200901 0.          0.       1
3200902 0.5         0.5     2
3200903 0.          0.       3
*      tlpvbfe   elem.
3201001 00000        4
*      efvcahs   giunz.
3201101 001000       3
*      ebt P(Pa) T(K) stato ? ? elem.
3201201 004 4.9e6 650.16 0.0 0. 0. 4
*      0:(m/s) 1:(kg/s)
3201300 1
*      mliq mgas ! giunz.
3201301 0. .225 0. 3
*-----
* Valvola Fv230 cv=0.512 k=3.81 + curva 900 K=0.5
*      Coeff. al 100%
*
3230000 Fv230 sngljun
*      da      a      sez.giun(m 2) Kf Kr efvcahs
3230101 320010000 325000000 0.01168 4.31 4.31 001000
*      (kg/s) mliq mgas !

```

```

3230201 1      0.    .225 0.
*-----
* Tubazione G parte terza (orizzontale)
*
* L=0.678 m, A=0.01168 m2, Didr=0.122 m
*
3250000 gltubo branch
*      tipo? (kg/s)
3250001 1      1
*      sez(m 2) lung(m) vol(m 3) azim incli elev(m) rug(m) Didr(m) tlpvbfe
3250101 0.01168 0.678 0.      270. 0.    0.      4.e-5 0.122 00000
*      ebt P(Pa) T(K)
3250200 004 4.9e6 650.16 0.0
*3251101 320010000 325000000 0. 0.5 0.5    001000
*      da      a      sez.giu(m 2) Kdir Kinv efvcahs
3251101 325010000 330000000 0.      0.0 0.0 001000
*      condizioni iniziali
*      mliq mgas !
3251201 0.    .225 0.
*3252201 0.    0.35 0.
*-----
* L=0.695 m, A=0.0042614 m2
* Sezione test parte prima (Imbocco sezione test orizzontale)
*
3300000 test1 branch
*      tipo? (kg/s)
3300001 2      1
*      sez(m 2) lung(m) vol(m 3) azim incli elev(m) rug(m) Didr(m) tlpvbfe
3300101 0.0042614 0.695 0.      270. 0.    0.      4.e-5 0.0 00000
*      ebt P(Pa) T(K)
3300200 004 4.9e6 650.16 0.0
*      da      a      sez.giu(m 2) Kdir Kinv efvcahs
3301101 325010000 330000000 0.      0.0 0.0 001000
*3302101 330010000 340000000 0.      1.    1.    001100
3302101 330010000 340000000 0.      1.0 1.0 001100
*      condizioni iniziali
*      mliq mgas !
3301201 0.    .225 0.
3302201 0.    .225 0.
*-----
* Sezione test parte seconda (tratto verticale con due distanziali)
* L=3.74 m
*
3400000 test2 pipe
*      partizioni
3400001 18
*      sez.(m 2) elemento
3400101 0.00668 1
3400102 0.0031023 2
3400103 0.001762 3
3400104 0.0015514 18
*      lung.(m) elem.
3400301 0.105 1
3400302 0.326 2
3400303 0.155 3
3400304 0.14 4
3400305 0.20 8
3400306 0.2214 18 *heating rods (2.214 m)
*      vol(m 3) elem.

```

```

3400401 0.          18
*        azimuth   elem.
3400501 0.          18
*        ang.vertic elem.
3400601 -90.         18
*        rugos(m)  Didr(m) elem
3400801 4.e-5         0.0566  1    *0.0
3400802 4.e-5         0.0316  2    *0.0
3400803 4.e-5         0.0198  3    *0.0
3400804 4.e-5         0.01492 18   *0.0
*        Kdir      Kinvr   giunzione
3400901 0.0         0.0      2
3400902 0.1         0.1      3
3400903 0.0         0.0      7
3400904 0.1         0.1      8
3400905 0.0         0.0     17
*        tlpvbfef elem.
3401001 00000        18
*        efvcahs   giunz.
3401101 001000       17
*        ebt P(Pa) T(K) stato ? ? elem.
3401201 004 4.9e6 650.16 0.0 0. 0. 18
*        0:(m/s) 1:(kg/s)
3401300 1
*        mliq mgas ! giunz.
3401301 0. .225 0. 17
*-----
* Lower Test Section: Branch invece di pipe per evitare irrealistica
stratificazione
*
3520000 test2 branch
*        tipo? (kg/s)
3520001 2 1
*        sez(m 2) lung(m) vol(m 3) azim incli elev(m) rug(m) Didr(m) tlpvbfef
3520101 0.00954 0.6995 0.          270. -90. -0.6995 4.e-5 0.0
00000
*        ebt P(Pa) T(K)
3520200 004 4.9e6 650.16 0.0
*        da      a          sez.giu(m 2) Kdir Kinv efvcahs
3521101 340010000 352000000 0.          0.62 0.62 001100
3522101 352000000 360000000 0.          0.65 0.65 001100
*        condizioni iniziali
*        mliq mgas !
3521201 0. .225 0.
3522201 0. .225 0.
*
*-----
* Sezione test parte terza (Parte verticale con due griglie)
*        perdite associate alle griglie K=0.1
*        L=3.74 m
*
3600000 test3 pipe
*        partizioni
3600001 18
*        sez.(m 2) elemento
3600101 0.0008344 10
3600102 0.0013305 18
*        lung.(m) elem.
3600301 0.2214 10

```

```

3600302 0.20      14
3600303 0.14      15
3600304 0.155     16
3600305 0.326     17
3600306 0.105     18
*      vol(m 3)  elem.
3600401 0.          18
*      azimut   elem.
3600501 0.          18
*      ang.vertic elem.
3600601 90.         18
*      rugos(m)  Didr(m) elem
3600801 4.e-5       0.0122  10
3600802 4.e-5       0.0      18
*      Kdir      Kinvr   giunzione
3600901 0.0         0.0      1
3600902 0.1         0.1      2 * 0.3
3600903 0.0         0.0      3
3600904 0.1         0.1      4 * 0.5
3600905 0.0         0.0      9
3600906 0.1         0.1     10 * 0.5
3600907 0.0         0.0     17
*      tlpvbfef elem.
3601001 00000       18
*      efvcahs   giunz.
3601101 001000      17
*      ebt P(Pa) T(K) stato ? ? elem.
3601201 004 4.9e6 650.16 0.0 0. 0. 18
*      0:(m/s) 1:(kg/s)
3601300 1
*      mliq mgas ! giunz.
3601301 0. .225 0. 17
*-----
* Sezione test parte quarta (ultimo tratto verticale)
*
* L=0.672 A=0.0013305m2, Didr=0.04116 m
*
3650000 test4 branch
*      tipo? (kg/s)
3650001 2 1
*      sez(m 2) lung(m) vol(m 3) azim incli elev(m) rug(m) Didr(m) tlpvbfef
3650101 0.0013305 0.672 0. 0. 90. 0.672 4.e-5 0.0 00000
*      ebt P(Pa) T(K)
3650200 004 4.9e6 650.16 0.0
*      da a sez.giu(m 2) Kdir Kinv efvcahs
3651101 360010000 365000000 0. 0.0 0.0 001000
3652101 365010000 367000000 0. 0.5 0.5 001000 * Allargamento
*      condizioni iniziali
*      mliq mgas !
3651201 0. .225 0.
3652201 0. .225 0.
*-----
* Sezione test parte quarta (ultimo tratto verticale + curva )
*
* L=0.429 m, A=0.0042614m2, Didr=0.07366 m
*
3670000 test4 branch
*      tipo? (kg/s)
3670001 1 1

```

```

*      sez(m 2) lung(m) vol(m 3) azim incli elev(m) rug(m) Didr(m) tlpvbf
3670101 0.0042614 0.429 0.      0.      90.      0.429  4.e-5  0.07366
00000
*      ebt  P(Pa) T(K)
3670200 004  4.9e6 650.16 0.0
*      da      a      sez.giu(m 2) Kdir  Kinv efvcahs
3671101 367010000 370000000 0.      0.35  0.35 001000 * curva
*3671101 367010000 370000000 0.      0.16  0.16 001000 * curva
*      condizioni iniziali
*      mliq mgas  !
3671201 0.      .225  0.
*-----
*  Sezione test  parte quarta (Uscita sezione test)
*
*  L=0.561 m, A=0.0042614 m2, Didr=0.07366 m
*
3700000 test5  branch
*      tipo? (kg/s)
3700001 1      1
*      sez(m 2) lung(m) vol(m 3) azim incli elev(m) rug(m) Didr(m) tlpvbf
3700101 0.0042614 0.561 0.      270. 0.      0.      4.e-5  0.0      00000
*      ebt  P(Pa) T(K)
3700200 004  4.9e6 650.16 0.0
*      da      a      sez.giu(m 2) Kdir  Kinv efvcahs
3701101 370010000 380000000 0.      0.7   0.7  001000
*3701101 370010000 380000000 0.      0.45  0.35 001000
*      condizioni iniziali
*      mliq mgas  !
3701201 0.      .225  0.
*-----
*  Tubazione A prima parte (curva a gomito K=0.5)
*
*  L=1.334 m, A=0.01168 m2, Didr=0.122 m
*
3800000 atub01 pipe
*      partizioni
3800001 2
*      sez.(m 2)  elemento
3800101 0.01168  2
*      lung.(m)  elem.
3800301 0.667    2
*      vol(m 3)  elem.
3800401 0.      2
*      azimut    elem.
3800501 270.      1
3800502 180.      2
*      ang.vertic elem.
3800601 0.      1
3800602 0.      2
*      rugos(m)  Didr(m) elem
3800801 4.e-5    0.122  2
*      Kdir      Kinvr  giunzione
3800901 0.5      0.5    1
*      tlpvbf    elem.
3801001 00000    2
*      efvcahs   giunz.
3801101 001000   1
*      ebt  P(Pa) T(K)  stato ? ?  elem.
3801201 004  4.9e6 630.16 0.0  0. 0.  2

```

```

*      0:(m/s) 1:(kg/s)
3801300 1
*      mliq mgas !   giunz.
3801301 0.   .225 0.  1
*-----
*  Valvola Fv231 cv=0.523 k=3.65
*      !!! Ansaldo coef. al 100%
*
3850000 Fv231 sngljun
*      da      a      sez.giun(m 2) Kf   Kr   efvcahs
3850101 380010000 390000000 0.      3.81 3.81 001000
*      (kg/s) mliq mgas !
3850201 1      0.   .225 0.
*-----
*  Tubazione A seconda parte (curva a gomito K=0.5)
*
*  L=1.02 m, A=0.01168 m2, Didr=0.122 m
*
3900000 atubo2 pipe
*      partizioni
3900001 2
*      sez.(m 2) elemento
3900101 0.01168 2
*      lung.(m) elem.
3900301 0.510 2
*      vol(m 3) elem.
3900401 0. 2
*      azimuth elem.
3900501 0. 2
*      ang.vertic elem.
3900601 -90. 2
*      rugos(m) Didr(m) elem
3900801 4.e-5 0.122 2
*      Kdir Kinvr giunzione
3900901 0.5 0.5 1
*      tlpvbf elem.
3901001 00000 2
*      efvcahs giunz.
3901101 001000 1
*      ebt P(Pa) T(K) stato ? ? elem.
3901201 004 4.9e6 630.16 0.0 0. 0. 2
*      0:(m/s) 1:(kg/s)
3901300 1
*      mliq mgas !   giunz.
3901301 0.   .225 0.  1
*-----
*  Imbocco economizzatore
*
3950000 inecon sngljun
*      da      a      sez.giun(m 2) Kf   Kr   efvcahs
3950101 390010000 400000000 0.      1.0 0.5 001000
*      (kg/s) mliq mgas !
3950201 1      0.   .225 0.
*-----
*  Economizzatore lato tubi Ltot=5.791 m, A(tubi)= 0.02063,
*  Didr(tubi)=0.0176 m
*
4000000 econ tub pipe
*      partizioni

```

```

4000001 42
*      sez.(m 2)  elemento
4000101 0.05726    1
4000102 0.266        2
4000103 0.02063      40
4000104 0.266        41
4000105 0.05726      42
*      lung.(m)  elem.
4000301 0.196        1
4000302 0.060        2
4000303 0.1315       40
4000304 0.075        41
4000305 0.460        42
*      vol(m 3)  elem.
4000401 0.            42
*      azimuth   elem.
4000501 0.            42
*      ang.vertic elem.
4000601 -90.          42
*      rugos(m)  Didr(m) elem
4000801 4.e-5        0.0    2
4000802 4.e-5        0.0176  40
4000803 4.e-5        0.0    42
*      Kdir      Kinvr   giunzione
4000901 1.            0.5    1
4000902 0.5           1.0    2
4000903 0.0           0.0    39
4000904 1.0           0.5    40
4000905 0.5           1.0    41
*      tlpvbfe   elem.
4001001 00000        42
*      efvcahs   giunz.
4001101 001000      41
*      ebt      P(Pa)  T(K)   stato ? ?   elem.
4001201 004  4.9e6  630.16  0.0  0. 0.  1
4001202 004  4.9e6  610.16  0.0  0. 0.  2
4001203 004  4.9e6  595.16  0.0  0. 0.  3
4001204 004  4.9e6  570.16  0.0  0. 0.  5
4001205 004  4.9e6  520.16  0.0  0. 0.  7
4001206 004  4.9e6  510.16  0.0  0. 0.  9
4001207 004  4.9e6  505.16  0.0  0. 0.  11
4001208 004  4.9e6  505.16  0.0  0. 0.  13
4001209 004  4.9e6  495.16  0.0  0. 0.  15
4001210 004  4.9e6  485.16  0.0  0. 0.  17
4001211 004  4.9e6  482.16  0.0  0. 0.  19
4001212 004  4.9e6  479.16  0.0  0. 0.  21
4001213 004  4.9e6  467.16  0.0  0. 0.  23
4001214 004  4.9e6  467.16  0.0  0. 0.  25
4001215 004  4.9e6  466.16  0.0  0. 0.  27
4001216 004  4.9e6  465.16  0.0  0. 0.  29
4001217 004  4.9e6  464.16  0.0  0. 0.  31
4001218 004  4.9e6  463.16  0.0  0. 0.  33
4001219 004  4.9e6  460.16  0.0  0. 0.  35
4001220 004  4.9e6  458.16  0.0  0. 0.  37
4001221 004  4.9e6  456.16  0.0  0. 0.  39
4001222 004  4.9e6  456.16  0.0  0. 0.  41
4001223 004  4.9e6  455.16  0.0  0. 0.  42
*      0:(m/s)  1:(kg/s)
4001300 1
  
```

```

*      mliq mgas !   giunz.
4001301 0.      .225 0.   41
*-----
*      Uscita economizzatore
*
4100000 jun8 sngljun
*      da      a      sez.giun(m 2) Kf      Kr      efvcahs
4100101 400010000 420000000 0.      0.5  1.0  001100
*      (kg/s) mliq mgas !
4100201 1      0.      .225 0.
*-----
*      Tubazione B parte prima
*      (restringimento K=0.5 + flangia tarata FT228 K=7)
*      coef. flangia al 100% K=6.3
*      L=2.008 m, A(restringimento)=0.00737-0.00144-0.00737 m2, Didr=0.043
*
4200000 btubo1 pipe
*      partizioni
4200001 4
*      sez.(m 2) elemento
4200101 0.00737  1
4200102 0.00144  3
4200103 0.00737  4
*      lung.(m) elem.
4200301 0.502    4
*      vol(m 3) elem.
4200401 0.      4
*      azimut elem.
4200501 0.      4
*      ang.vertic elem.
4200601 -90.    4
*      rugos(m) Didr(m) elem
4200801 4.e-5    0.043  4
*      Kdir Kinvr giunzione
4200901 0.5    1.0    1
4200902 7.     7.     2
4200903 1.0    0.5    3
*      tlpvbfe elem.
4201001 00000    4
*      efvcahs giunz.
4201101 001000    3
*      ebt P(Pa) T(K) stato ? ? elem.
4201201 004  4.9e6 455.16 0.0  0. 0. 4
*      0:(m/s) 1:(kg/s)
4201300 1
*      mliq mgas !   giunz.
4201301 0.      .225 0.   3
*-----
*      Tubazione B parte seconda (curva 900 K=0.5 + tee K=1 + mixer K=5)
*
*      L=1.718 m, A=0.00737 m2, Didr=0.097
*
4300000 btubo2 branch
*      tipo? (kg/s)
4300001 2      1
*      sez(m 2) lung(m) vol(m 3) azim incli elev(m) rug(m) Didr(m) tlpvbfe
4300101 0.00737 1.718 0.      0.   -90. -1.718 4.e-5 0.097 00000
*      ebt P(Pa) T(K)
4300200 004  4.9e6 455.16 0.0

```

```

*      da      a      sez.giu(m 2) Kdir  Kinv  efvcahs
4301101 420010000 430000000 0.      0.0   0.0   001000
4302101 430010000 440000000 0.      6.5   6.5   001000
*      condizioni iniziali
*      mliq mgas !
4301201 0.      .225 0.
4302201 0.      .225 0.

```

```

*-----
* Tubazione B parte terza
*
* L=2.62 m, A=0.00737 m2, Didr=0.097 m
*

```

```

4400000 btubo3 pipe
*      partizioni
4400001 2
*      sez.(m 2) elemento
4400101 0.00737 2
*      lung.(m) elem.
4400301 1.31    2
*      vol(m 3) elem.
4400401 0.      2
*      azimut elem.
4400501 90.     2
*      ang.vertic elem.
4400601 0.      2
*      rugos(m) Didr(m) elem
4400801 4.e-5   0.097 2
*      Kdir  Kinvr  giunzione
4400901 0.0    0.0    1
*      tlpvbf  elem.
4401001 00000 2
*      efvcahs giunz.
4401101 001000 1
*      ebt P(Pa) T(K) stato ? ? elem.
4401201 004 4.9e6 455.16 0.0 0. 0. 2
*      0:(m/s) 1:(kg/s)
4401300 1
*      mliq mgas ! giunz.
4401301 0.      .225 0. 1

```

```

*-----
*
4500000 jun9 sngljun
*      da      a      sez.giun(m 2) Kf  Kr  efvcahs
4500101 440010000 460000000 0.      1.0  0.5  001100
*      (kg/s) mliq mgas !
4500201 1      0.      .225 0.
*-----
* Aeroterma parte tubi
* (considerati pressure drop coeff. k=0.8 nelle curvature) Ltot=13.502 m
* H=0.572 m, A=0.007371-0.005661-0.007371, Didr=0.097-0.018-0.097
*

```

```

4600000 aero pipe
*      partizioni
4600001 13
*      sez.(m 2) elemento
4600101 0.007371 1
4600102 0.005661 12
4600103 0.007371 13
*      lung.(m) elem.

```

```

4600301 1.251      1
4600302 1.000      12
4600303 1.251      13
*      vol(m 3)   elem.
4600401 0.            13
*      azimut    elem.
4600501 0.            13
*      ang.vertic elem.
4600601 0.            1
4600602 -90.          12
4600603 0.            13
*      Dzx(m)    elem
4600701 0.            1
4600702 -0.052       12
4600703 0.            13
*      rugos(m)  Didr(m) elem
4600801 4.e-5         0.097  1
4600802 4.e-5         0.018  12
4600803 4.e-5         0.097  13
*      Kdir     Kinvr   giunzione
4600901 0.5         1.0     1
4600902 0.8         0.8     11
4600903 1.0         0.5     12
*      tlpvbf  elem.
4601001 00000        13
*      efvcahs giunz.
4601101 001000       12
*      ebt P(Pa) T(K) stato ? ? elem.
4601201 004 4.9e6  455.16 0.0  0. 0. 13
*      0:(m/s) 1:(kg/s)
4601300 1
*      mliq mgas ! giunz.
4601301 0.      .225 0. 12
*-----
*
4700000 jun10 sngljun
*      da      a      sez.giun(m 2) Kf   Kr   efvcahs
4700101 460010000 480000000 0.      0.5  1.0  001100
*      (kg/s) mliq mgas !
4700201 1      0.      .225 0.
*-----
* Tubazione C
* ( restringimento filtro + valvola FV10 + curva 900
k=0.5+(Ansaldo)50.5+3+0.5)
*      coeff. filtro e valvola al 100%
*
*      Ltot=3.45 m, A=0.007371-0.002163 m, Didr=0.097-0.052 m
*
4800000 ctubo3 pipe
*      partizioni
4800001 9
*      sez.(m 2) elemento
4800101 0.007371  5
4800102 0.002163  9
*      lung.(m) elem.
4800301 0.47      5
4800302 0.275     9
*      vol(m 3) elem.
4800401 0.            9

```

```

*      azimut      elem.
4800501 90.      8
4800502 0.      9
*      ang.vertic elem.
4800601 0.      9
*      rugos(m)   Didr(m) elem
4800801 4.e-5      0.097 5
4800802 4.e-5      0.052 9
*      Kdir      Kinvr   giunzione
4800901 0.5      1.0      5
4800902 65.5      65.5      6      *vlv FV 10
4800903 3.      3.      7      *filtro
4800904 0.5      0.5      8
*
*      tlpvbfefe elem.
4801001 00000      9
*      efvcahs   giunz.
4801101 001000      8
*      ebt P(Pa) T(K) stato ? ? elem.
4801201 004 4.9e6 343.16 0.0 0. 0. 9
*      0:(m/s) 1:(kg/s)
4801300 1
*      mliq mgas ! giunz.
4801301 0. .225 0. 8
*-----
*
6000000 compres pump
*      sez(m 2) lung(m) vol(m 3) azim inclin elev(m) tlpvbfefe
6000101 0.      0.2      2.e-3      0. 90.      0.2      0000000
*      da      sez(m 2) Kdir Kinvr efvcahs
6000108 480010000 .001      1. 1. 0000000
*      a      sez(m 2) Kdir Kinvr efvcahs
6000109 120000000 .001      1. 1. 0000000
*      ebt P(Pa) T(K)
6000200 004 4.9e6 358.16 0.0
*      condizioni iniziali ingresso
*      (kg/s) mliq mgas !
6000201 1      0. .225 0.
*      condizioni iniziali uscita
*      (kg/s) mliq mgas !
6000202 1      0. .225 0.
*      dati sper monofasico ! torque w trip retromarcia
6000301 0      -1      -3      -1      0 501      0
*      w(rad/s) wi/w Vi'(m 3/s) head(m) torque(Nm) Inerzia(kg*m 2)
6000302 1361.      0.976      0.0285      3896.25 22.000      0.001
*      ro(kg/m 3) (Nm) TF2 TF0 TF1 TF3 tutti in (Nm)
6000303 6.75      0.      0. 0. 0. 0.
*
*
*-----
*
*      head curves new
*
6001100 1 1
*      v/a      h/a 2
6001101 0.      1.6
6001102 0.052      1.598
6001103 0.156      1.532

```

6001104	0.312	1.434
6001105	0.469	1.335
6001106	0.625	1.236
6001107	0.745	1.163
6001108	0.891	1.062
6001109	1.0	1.0
*		
*		
6001200	1 2	
*	a/v	h/v 2
6001201	0.0	0.0
6001202	0.2	0.0133
6001203	0.4	0.0855
6001204	0.6	0.254
6001205	0.8	0.549
6001206	0.9	0.753
6001207	0.95	0.871
6001208	1.0	1.0
*		
*	(v/a)	
*		
6001300	1 3	
6001301	-1.	1.6
6001302	0.	1.6
*		
*	(a/v)	
*		
6001400	1 4	
6001401	-1.	0.0
6001402	0.	0.0
*		
*	(v/a)	
*		
6001500	1 5	
6001501	0.	1.6
6001502	1.	1.6
*		
*	(a/v)	
*		
6001600	1 6	
6001601	0.	0.0
6001602	1.	0.0
*		
*	(v/a)	
*		
6001700	1 7	
6001701	-1.	1.6
6001702	0.	1.6
*		
*	(a/v)	
*		
6001800	1 8	
6001801	-1.	0.0
6001802	0.	0.0
*		
*		
*	torque curves	
*		
*		

6001900 2 1
* v/a b/a 2
6001901 0. 1.13
6001902 0.052 1.128
6001903 0.156 1.112
6001904 0.312 1.089
6001905 0.469 1.066
6001906 0.625 1.043
6001907 0.745 1.028
6001908 0.891 1.01
6001909 1.0 1.002

*

*

6002000 2 2
* a/v b/v 2
6002001 0. 0.
6002002 0.2 0.022
6002003 0.4 0.114
6002004 0.6 0.298
6002005 0.8 0.59
6002006 0.9 0.781
6002007 0.95 0.887
6002008 1.0 1.002

*

*

6002100 2 3
6002101 -1. 1.13
6002102 0. 1.13

*

*

(v/a)

*

6002200 2 4
6002201 -1. 0.0
6002202 0. 0.0
*
6002300 2 5
6002301 0. 1.13
6002302 1. 1.13

*

6002400 2 6
6002401 0. 0.0
6002402 1. 0.0

*

6002500 2 7
6002501 -1. 1.13
6002502 0. 1.13

*

6002600 2 8
6002601 -1. 0.0
6002602 0. 0.0

*

*

* Regolazione compressore sulla portata

*

6006100 610 cntlvar 100
* search? w(rad/s)
6006101 0. 0.0
6006102 2000. 2000.0

```

*
* Regolazione compressore sul numero di giri per controllo nuove curve
omologhe
*6006100 610
*
*      time      w(rad/s)
*6006101 0.      1361.
*6006102 300.    1361.
*6006103 350.    1257.
*6006104 400.    1257.
*6006105 450.    1047.
*6006106 500.    1047.
*
*
*-----
*                               Heat Structures
*-----
*
* Riscaldatori primo modulo
*
* 60 barre di MgO D=15 mm, rivestimento di un fodero di acciaio S=1 mm,
*
* Ltot=2100 mm, Lscaldante=1800 mm, Ptermica=70 kwatt
*
* 13 elementi con 15 punti di calcolo
*
12401000 13 15 2 1 0.
12401100 0 2
12401101 7.5e-04 2
12401102 5.0e-04 12
12401103 5.0e-04 14
12401201 3 12
12401202 1 14
12401301 1. 14
12401400 0
12401401 800. 15
12401501 0 0 0 0 0. 13
12401601 240020000 10000 1 1 9.8181 11
12401602 240130000 10000 1 1 9.0 13
12401701 101 0.0909 0. 0. 11
12401702 0 0. 0. 0. 13
12401901 1.67e-2 15. 15. 0. 0. 0. 0. 1. 13
*
*
* Riscaldatori secondo modulo
*
* 60 barre di MgO D=15 mm, rivestimento di un fodero di acciaio S=1 mm,
*
* Ltot=2100 mm, Lscaldante=1800 mm, Ptermica=70 kwatt
*
* 13 elementi con 15 punti di calcolo
*
12601000 13 15 2 1 0.
12601100 0 2
12601101 7.5e-04 2
12601102 5.0e-04 12
12601103 5.0e-04 14
12601201 3 12
12601202 1 14
12601301 1. 14

```

12601400 0
12601401 835. 15
12601501 0 0 0 0 0. 13
12601601 260010000 10000 1 1 9.0 2
12601602 260030000 10000 1 1 9.8181 13
12601701 0 0. 0. 0. 2
12601702 102 0.0909 0. 0. 13
12601901 1.67e-2 15. 15. 0. 0. 0. 0. 1. 13

*

*

* Riscaldatori terzo modulo

*

* 60 barre di MgO D=15 mm, rivestimento di un fodero di acciaio S=1 mm,

*

* Ltot=2100 mm, Lscaldante=1800 mm, Ptermica=70 kwatt

*

* 13 elementi con 15 punti di calcolo

*

13001000 13 15 2 1 0.
13001100 0 2
13001101 7.5e-04 2
13001102 5.0e-04 12
13001103 5.0e-04 14
13001201 3 12
13001202 1 14
13001301 1. 14
13001400 0
13001401 870. 15
13001501 0 0 0 0 0. 13
13001601 300010000 10000 1 1 9.0 2
13001602 300030000 10000 1 1 9.8181 13
13001701 0 0. 0. 0. 2
13001702 103 0.0909 0. 0. 13
13001901 1.67e-2 15. 15. 0. 0. 0. 0. 1. 13

*

*

* Economizzatore tubi 1/2 NO tubi: 73, L=5000 mm, S(acciaio)=1.6 mm,
De=21.3 mm

*

14001000 38 9 2 1 0.00905
14001100 0 1
14001101 8 0.01065
14001201 1 8
14001301 0. 8
14001400 -1
14001401 470. 470. 470. 470. 470. 470. 470. 470. 470.
14001402 470. 470. 470. 470. 470. 470. 470. 470. 470.
14001403 480. 480. 480. 480. 480. 480. 480. 480. 480.
14001404 480. 480. 480. 480. 480. 480. 480. 480. 480.
14001405 495. 495. 495. 495. 495. 495. 495. 495. 495.
14001406 495. 495. 495. 495. 495. 495. 495. 495. 495.
14001407 507. 507. 507. 507. 507. 507. 507. 507. 507.
14001408 507. 507. 507. 507. 507. 507. 507. 507. 507.
14001409 520. 520. 520. 520. 520. 520. 520. 520. 520.
14001410 520. 520. 520. 520. 520. 520. 520. 520. 520.
14001411 532. 532. 532. 532. 532. 532. 532. 532. 532.
14001412 532. 532. 532. 532. 532. 532. 532. 532. 532.
14001413 545. 545. 545. 545. 545. 545. 545. 545. 545.
14001414 545. 545. 545. 545. 545. 545. 545. 545. 545.



14001415 557. 557. 557. 557. 557. 557. 557. 557. 557.
 14001416 557. 557. 557. 557. 557. 557. 557. 557. 557.
 14001417 569. 569. 569. 569. 569. 569. 569. 569. 569.
 14001418 569. 569. 569. 569. 569. 569. 569. 569. 569.
 14001419 582. 582. 582. 582. 582. 582. 582. 582. 582.
 14001420 582. 582. 582. 582. 582. 582. 582. 582. 582.
 14001421 595. 595. 595. 595. 595. 595. 595. 595. 595.
 14001422 595. 595. 595. 595. 595. 595. 595. 595. 595.
 14001423 607. 607. 607. 607. 607. 607. 607. 607. 607.
 14001424 607. 607. 607. 607. 607. 607. 607. 607. 607.
 14001425 620. 620. 620. 620. 620. 620. 620. 620. 620.
 14001426 620. 620. 620. 620. 620. 620. 620. 620. 620.
 14001427 632. 632. 632. 632. 632. 632. 632. 632. 632.
 14001428 632. 632. 632. 632. 632. 632. 632. 632. 632.
 14001429 645. 645. 645. 645. 645. 645. 645. 645. 645.
 14001430 645. 645. 645. 645. 645. 645. 645. 645. 645.
 14001431 658. 658. 658. 658. 658. 658. 658. 658. 658.
 14001432 658. 658. 658. 658. 658. 658. 658. 658. 658.
 14001433 671. 671. 671. 671. 671. 671. 671. 671. 671.
 14001434 671. 671. 671. 671. 671. 671. 671. 671. 671.
 14001435 684. 684. 684. 684. 684. 684. 684. 684. 684.
 14001436 684. 684. 684. 684. 684. 684. 684. 684. 684.
 14001437 696. 696. 696. 696. 696. 696. 696. 696. 696.
 14001438 696. 696. 696. 696. 696. 696. 696. 696. 696.
 14001501 400400000 -10000 1 1 9.605 38
 14001601 200010000 10000 110 1 9.605 38
 *14001601 200010000 10000 1 1 9.605 38
 14001701 0 0. 0. 0. 38
 14001801 0. 15. 15. 0. 0. 0. 0. 1. 38
 14001900 1
 * Dth Hlf Hlr gslf gslr gKF gKR boilf natcl PvsD FF Hstr
 14001901 0. 15. 15. 0. 0. 0. 0. 1. 0.25 1.37 1.0 38
 *
 * Economizzatore tubi 3/8 N0 tubi: 12, L=5000 mm, S(acciaio)=1.0 mm, De=16 mm
 *
 14002000 38 9 2 1 0.007
 14002100 0 1
 14002101 8 0.008
 14002201 1 8
 14002301 0. 8
 14002400 -1
 14002401 470. 470. 470. 470. 470. 470. 470. 470. 470.
 14002402 470. 470. 470. 470. 470. 470. 470. 470. 470.
 14002403 480. 480. 480. 480. 480. 480. 480. 480. 480.
 14002404 480. 480. 480. 480. 480. 480. 480. 480. 480.
 14002405 495. 495. 495. 495. 495. 495. 495. 495. 495.
 14002406 495. 495. 495. 495. 495. 495. 495. 495. 495.
 14002407 507. 507. 507. 507. 507. 507. 507. 507. 507.
 14002408 507. 507. 507. 507. 507. 507. 507. 507. 507.
 14002409 520. 520. 520. 520. 520. 520. 520. 520. 520.
 14002410 520. 520. 520. 520. 520. 520. 520. 520. 520.
 14002411 532. 532. 532. 532. 532. 532. 532. 532. 532.
 14002412 532. 532. 532. 532. 532. 532. 532. 532. 532.
 14002413 545. 545. 545. 545. 545. 545. 545. 545. 545.
 14002414 545. 545. 545. 545. 545. 545. 545. 545. 545.
 14002415 557. 557. 557. 557. 557. 557. 557. 557. 557.
 14002416 557. 557. 557. 557. 557. 557. 557. 557. 557.
 14002417 569. 569. 569. 569. 569. 569. 569. 569. 569.

```

14002418 569. 569. 569. 569. 569. 569. 569. 569. 569.
14002419 582. 582. 582. 582. 582. 582. 582. 582. 582.
14002420 582. 582. 582. 582. 582. 582. 582. 582. 582.
14002421 595. 595. 595. 595. 595. 595. 595. 595. 595.
14002422 595. 595. 595. 595. 595. 595. 595. 595. 595.
14002423 607. 607. 607. 607. 607. 607. 607. 607. 607.
14002424 607. 607. 607. 607. 607. 607. 607. 607. 607.
14002425 620. 620. 620. 620. 620. 620. 620. 620. 620.
14002426 620. 620. 620. 620. 620. 620. 620. 620. 620.
14002427 632. 632. 632. 632. 632. 632. 632. 632. 632.
14002428 632. 632. 632. 632. 632. 632. 632. 632. 632.
14002429 645. 645. 645. 645. 645. 645. 645. 645. 645.
14002430 645. 645. 645. 645. 645. 645. 645. 645. 645.
14002431 658. 658. 658. 658. 658. 658. 658. 658. 658.
14002432 658. 658. 658. 658. 658. 658. 658. 658. 658.
14002433 671. 671. 671. 671. 671. 671. 671. 671. 671.
14002434 671. 671. 671. 671. 671. 671. 671. 671. 671.
14002435 684. 684. 684. 684. 684. 684. 684. 684. 684.
14002436 684. 684. 684. 684. 684. 684. 684. 684. 684.
14002437 696. 696. 696. 696. 696. 696. 696. 696. 696.
14002438 696. 696. 696. 696. 696. 696. 696. 696. 696.
14002501 400400000 -10000 1 1 1.58 38
14002601 200010000 10000 110 1 1.58 38
14002701 0 0. 0. 0. 38
14002801 0. 15. 15. 0. 0. 0. 0. 1. 38
14002900 1
*      Dth Hlf Hlr gslf gslr gKF gKR boilf natcl PvsD FF Hstr
14002901 0. 15. 15. 0. 0. 0. 0. 1. 0.25 1.37 1.0 38
*
*
*      Strutture Esterne (Rivestimento)
*
*
*      Struttura tubo P elemento 120 L=1. m S(acciaio)=3.91 mm S(fibra
vetro)=60. mm
*
11201000 2 9 2 1 0.02609
11201100 0 2
11201101 1.95e-3 1
11201102 1.95e-3 2
11201103 0.01 8
11201201 1 2
11201202 2 8
11201301 0. 8
11201400 0
11201401 433. 3
11201402 408. 4
11201403 383. 5
11201404 358. 6
11201405 333. 7
11201406 308. 8
11201407 295. 9
11201501 120010000 10000 1 1 0.5 2
11201601 -200 0 4300 1 0.5 2
11201701 0 0. 0. 0. 2
11201801 0. 15. 15. 0. 0. 0. 0. 1. 2
11201901 0. 15. 15. 0. 0. 0. 0. 1. 2
*

```

*

* Struttura Vessel elemento 140 L=4.615 m, S(acciaio)=45. mm, S(fibra vetro)=100. mm

*

11401000 5 16 2 1 0.455
11401100 0 2
11401101 0.009 5
11401104 0.01 15
11401201 1 5
11401202 2 15
11401301 0. 15
11401400 0.
11401401 431. 6
11401402 416. 7
11401403 401. 8
11401404 386. 9
11401405 371. 10
11401406 356. 11
11401407 341. 12
11401408 326. 13
11401409 311. 14
11401410 300. 15
11401411 290. 16
11401501 140010000 10000 1 1 0.923 5
11401601 -200 0 4300 1 0.923 5
11401701 0 0. 0. 0. 5
11401801 0. 15. 15. 0. 0. 0. 0. 1. 5
11401901 0. 15. 15. 0. 0. 0. 0. 1. 5

*

*

* Tubo D prima parte elemento 160 L=7.919 m, S(acciaio)=8.56 mm, S(fibra vetro)=60. mm

*

11601000 9 9 2 1 0.0484
11601100 0 2
11601101 0.00428 1
11601102 0.00428 2
11601103 0.01 8
11601201 1 2
11601202 2 8
11601301 0. 8
11601400 0
11601401 432. 3
11601402 408. 4
11601403 383. 5
11601404 358. 6
11601405 333. 7
11601406 308. 8
11601407 295. 9
11601501 160010000 10000 1 1 0.8799 9
11601601 -200 0 4300 1 0.8799 9
11601701 0 0. 0. 0. 9
11601801 0. 15. 15. 0. 0. 0. 0. 1. 9
11601901 0. 15. 15. 0. 0. 0. 0. 1. 9

*

*

*

* Tubo D parte seconda elemento 170 L=2.902 m, S(acciaio)=8.56 mm, S(fibra vetro)=60. mm

*

11701000 1 9 2 1 0.0484
11701100 0 2
11701101 0.00428 2
11701102 0.01 8
11701201 1 2
11701202 2 8
11701301 0. 8
11701400 0
11701401 431. 3
11701402 408. 4
11701403 383. 5
11701404 358. 6
11701405 333. 7
11701406 308. 8
11701407 295. 9
11701501 170010000 0 1 1 2.902 1
11701601 -200 0 4300 1 2.902 1
11701701 0 0. 0. 0. 1
11701801 0. 15. 15. 0. 0. 0. 0. 1. 1
11701901 0. 15. 15. 0. 0. 0. 0. 1. 1

*

*

* Tubo I parte prima elemento 171 L=2.5064 m, S(acciaio)=8.56 mm,
S(fibra vetro)=60 mm

*

11711000 4 9 2 1 0.0484
11711100 0 2
11711101 0.00428 2
11711102 0.01 8
11711201 1 2
11711202 2 8
11711301 0. 8
11711400 0
11711401 420. 3
11711402 408. 4
11711403 383. 5
11711404 358. 6
11711405 333. 7
11711406 308. 8
11711407 295. 9
11711501 171010000 0 1 1 0.6266 4
11711601 -200 0 4302 1 0.6266 4
11711701 0 0. 0. 0. 4
11711801 0. 15. 15. 0. 0. 0. 0. 1. 4
11711901 0. 15. 15. 0. 0. 0. 0. 1. 4

*

*

* Tubo I parte seconda elemento 315 L=2.665 m, S(acciaio)=8.56 mm,
S(fibra vetro)=60 mm

*

13151000 4 9 2 1 0.0484
13151100 0 2
13151101 0.00428 2
13151102 0.01 8
13151201 1 2
13151202 2 8
13151301 0. 8
13151400 0

13151401 423. 3
13151402 408. 4
13151403 383. 5
13151404 358. 6
13151405 333. 7
13151406 308. 8
13151407 295. 9
13151501 315010000 0 1 1 0.66625 4
13151601 -200 0 4300 1 0.66625 4
13151701 0 0. 0. 0. 4
13151801 0. 15. 15. 0. 0. 0. 0. 1. 4
13151901 0. 15. 15. 0. 0. 0. 0. 1. 4

*

*

* Tubo D parte terza elemento 173 L=600. mm, S(acciaio)=8.56 mm, S(fibra vetro)=60. mm

*

11731000 1 9 2 1 0.0484
11731100 0 2
11731101 0.00428 2
11731102 0.01 8
11731201 1 2
11731202 2 8
11731301 0. 8
11731400 0
11731401 431. 3
11731402 408. 4
11731403 383. 5
11731404 358. 6
11731405 333. 7
11731406 308. 8
11731407 295. 9
11731501 173010000 10000 1 1 0.600 1
11731601 -200 0 4300 1 0.600 1
11731701 0 0. 0. 0. 1
11731801 0. 15. 15. 0. 0. 0. 0. 1. 1
11731901 0. 15. 15. 0. 0. 0. 0. 1. 1

*

*

*

* Tubo D parte quarta elemento 180 L=600. mm, S(acciaio)=8.56 mm, S(fibra vetro)=60. mm

*

11801000 1 9 2 1 0.0484
11801100 0 2
11801101 0.00428 2
11801102 0.01 8
11801201 1 2
11801202 2 8
11801301 0. 8
11801400 0
11801401 421. 3
11801402 408. 4
11801403 383. 5
11801404 358. 6
11801405 333. 7
11801406 308. 8
11801407 295. 9
11801501 180020000 10000 1 1 0.600 1

11801601 -200 0 4300 1 0.600 1

11801701 0 0. 0. 0. 1

11801801 0. 15. 15. 0. 0. 0. 0. 1. 1

11801901 0. 15. 15. 0. 0. 0. 0. 1. 1

*

*

* Rivestimento economizzatore L=5000 mm, S(acciaio)=20 mm, S(fibra vetro)=160 mm

*

12001000 38 16 2 1 0.135

12001100 0 2

12001101 4.0e-3 5

12001102 0.016 15

12001201 1 5

12001202 9 15

12001301 0. 15

12001400 0

12001401 660. 6

12001402 622. 7

12001403 584. 8

12001404 546. 9

12001405 506. 10

12001406 470. 11

12001407 432. 12

12001408 394. 13

12001409 356. 14

12001410 318. 15

12001411 295. 16

12001501 200010000 10000 1 1 0.1315 38

12001601 -200 0 4303 1 0.1315 38

12001701 0 0. 0. 0. 38

12001801 0.270 15. 15. 0. 0. 0. 0. 1. 38 *

12001901 0. 15. 15. 0. 0. 0. 0. 1. 38

*

*

*

* Tubo E rivestimento esterno prima parte L=0.626 m, S(acciaio)=8.56 mm, S(fibra vetro)=160 mm

*

12101000 1 13 2 1 0.04843

12101100 0 2

12101101 0.00428 2

12101102 0.016 12

12101201 1 2

12101202 4 12

12101301 0. 12

12101400 0

12101401 900. 3

12101402 838. 4

12101403 776. 5

12101404 714. 6

12101405 652. 7

12101406 590. 8

12101407 528. 9

12101408 466. 10

12101409 404. 11

12101410 342. 12

12101411 300. 13

12101501 210010000 0 1 1 0.626 1

12101601 -200 0 4300 1 0.626 1
12101701 0 0. 0. 0. 1
12101801 0. 15. 15. 0. 0. 0. 0. 1. 1
12101901 0.0 15. 15. 0. 0. 0. 0. 1. 1

*
*
*

* Tubo E rivestimento esterno parte seconda L=2.332 m, S(acciaio)=8.56
mm, S(fibra vetro)=160 mm

*

12201000 2 13 2 1 0.04843
12201100 0 2
12201101 0.00428 2
12201102 0.016 12
12201201 1 2
12201202 4 12
12201301 0. 12
12201400 0
12201401 900. 3
12201402 838. 4
12201403 776. 5
12201404 714. 6
12201405 652. 7
12201406 590. 8
12201407 528. 9
12201408 466. 10
12201409 404. 11
12201410 342. 12
12201411 300. 13
12201501 220010000 10000 1 1 1.166 2
12201601 -200 0 4300 1 1.166 2
12201701 0 0. 0. 0. 2
12201801 0. 15. 15. 0. 0. 0. 0. 1. 2
12201901 0. 15. 15. 0. 0. 0. 0. 1. 2

*
*

* Tubo E rivestimento esterno parte terza L=2.084 m, S(acciaio)=8.56
mm, S(fibra vetro)=160 mm

*

12301000 1 13 2 1 0.04843
12301100 0 2
12301101 0.00428 2
12301102 0.016 12
12301201 1 2
12301202 4 12
12301301 0. 12
12301400 0
12301401 900. 3
12301402 838. 4
12301403 776. 5
12301404 714. 6
12301405 652. 7
12301406 590. 8
12301407 528. 9
12301408 466. 10
12301409 404. 11
12301410 342. 12
12301411 300. 13
12301501 230010000 0 1 1 2.084 1

12301601 -200 0 4300 1 2.084 1
12301701 0 0. 0. 0. 1
12301801 0. 15. 15. 0. 0. 0. 0. 1. 1
12301901 0. 15. 15. 0. 0. 0. 0. 1. 1

*

*

* Riscaldatore 1 rivestimento esterno L=2230 mm, S(acciaio)=20 mm,
S(fibra vetro)=160 mm

*

12402000 14 15 2 1 0.135
12402100 0 2
12402101 5.0e-3 4
12402102 0.016 14
12402201 1 2
12402202 4 14
12402301 0. 14
12402400 0
12402401 930. 5
12402402 865. 6
12402403 800. 7
12402404 735. 8
12402405 670. 9
12402406 605. 10
12402407 540. 11
12402408 475. 12
12402409 410. 13
12402410 345. 14
12402411 300. 15
12402501 240010000 10000 1 1 0.130 1
12402502 240020000 10000 1 1 0.16363 12
12402503 240130000 10000 1 1 0.150 14
12402601 -200 0 4301 1 0.130 1
12402602 -200 0 4301 1 0.16363 12
12402603 -200 0 4301 1 0.150 14
12402701 0 0. 0. 0. 14
12402801 0.001 15. 15. 0. 0. 0. 0. 1. 14
12402901 0. 15. 15. 0. 0. 0. 0. 1. 14

*

*

*

* Tubo F rivestimento esterno parte prima L=0.528 m, S(acciaio)= 8.56
mm, S(isolante)=160 mm

*

12501000 1 13 2 1 0.0505
12501100 0 2
12501101 4.76e-3 2
12501102 0.016 12
12501201 1 2
12501202 4 12
12501301 0. 12
12501400 0
12501401 930. 3
12501402 865. 4
12501403 800. 5
12501404 735. 6
12501405 670. 7
12501406 605. 8
12501407 540. 9
12501408 475. 10

12501409 410. 11
12501410 345. 12
12501411 300. 13
12501501 250010000 0 1 1 0.528 1
12501601 -200 0 4300 1 0.528 1
12501701 0 0. 0. 0. 1
12501801 0. 15. 15. 0. 0. 0. 0. 1. 1
12501901 0. 15. 15. 0. 0. 0. 0. 1. 1

*

*

*

* Riscaldatore 2 rivestimento esterno L=2230 mm, S(acciaio)=20 mm,
S(fibra vetro)=160 mm

*

12602000 14 15 2 1 0.135
12602100 0 2
12602101 5.0e-3 4
12602102 0.016 14
12602201 1 2
12602202 4 14
12602301 0. 14
12602400 0
12602401 970. 5
12602402 901. 6
12602403 832. 7
12602404 763. 8
12602405 694. 9
12602406 625. 10
12602407 556. 11
12602408 487. 12
12602409 418. 13
12602410 349. 14
12602411 305. 15
12602501 260010000 10000 1 1 0.150 2
12602502 260030000 10000 1 1 0.16363 13
12602503 260140000 10000 1 1 0.130 14
12602601 -200 0 4301 1 0.150 2
12602602 -200 0 4301 1 0.16363 13
12602603 -200 0 4301 1 0.130 14
12602701 0 0. 0. 0. 14
12602801 0.001 15. 15. 0. 0. 0. 0. 1. 14
12602901 0. 15. 15. 0. 0. 0. 0. 1. 14

*

*

* Tubo F rivestimento esterno parte seconda L=0.933 m, S(acciaio)= 8.56
mm, S(isolante)=160 mm

*

12701000 1 13 2 1 0.06194
12701100 0 2
12701101 4.76e-3 2
12701102 0.016 12
12701201 1 2
12701202 4 12
12701301 0. 12
12701400 0
12701401 970. 3
12701402 901. 4
12701403 832. 5
12701404 763. 6

12701405 694. 7
12701406 625. 8
12701407 556. 9
12701408 487. 10
12701409 418. 11
12701410 349. 12
12701411 305. 13
12701501 270010000 0 1 1 0.933 1
12701601 -200 0 4300 1 0.933 1
12701701 0 0. 0. 0. 1
12701801 0. 15. 15. 0. 0. 0. 0. 1. 1
12701901 0. 15. 15. 0. 0. 0. 0. 1. 1

*

*

* Tubo F rivestimento esterno parte terza L=2.23 m, S(acciaio)= 8.56 mm,
S(isolante)=160 mm

*

12801000 2 13 2 1 0.06194
12801100 0 2
12801101 4.76e-3 2
12801102 0.016 12
12801201 1 2
12801202 4 12
12801301 0. 12
12801400 0
12801401 970. 3
12801402 901. 4
12801403 832. 5
12801404 763. 6
12801405 694. 7
12801406 625. 8
12801407 556. 9
12801408 487. 10
12801409 418. 11
12801410 349. 12
12801411 305. 13
12801501 280010000 10000 1 1 1.115 2
12801601 -200 0 4300 1 1.115 2
12801701 0 0. 0. 0. 2
12801801 0. 15. 15. 0. 0. 0. 0. 1. 2
12801901 0. 15. 15. 0. 0. 0. 0. 1. 2

*

*

* Tubo F rivestimento esterno parte quarta L=0.528 m, S(acciaio)= 8.56
mm, S(isolante)=160 mm

*

12901000 1 13 2 1 0.06194
12901100 0 2
12901101 4.28e-3 2
12901102 0.016 12
12901201 1 2
12901202 4 12
12901301 0. 12
12901400 0
12901401 970. 3
12901402 901. 4
12901403 832. 5
12901404 763. 6
12901405 694. 7

12901406 625. 8
12901407 556. 9
12901408 487. 10
12901409 418. 11
12901410 349. 12
12901411 305. 13
12901501 290010000 0 1 1 0.528 1
12901601 -200 0 4300 1 0.528 1
12901701 0 0. 0. 0. 1
12901801 0. 15. 15. 0. 0. 0. 0. 1. 1
12901901 0. 15. 15. 0. 0. 0. 0. 1. 1

*

*

* Riscaldatore 3 rivestimento esterno L=2230 mm, S(acciaio)=20 mm, S(fibra vetro)=160 mm

* Diam. est. 0.63 m.

*

13002000 14 15 2 1 0.135
13002100 0 2
13002101 5.0e-3 4
13002102 0.016 14
13002201 1 2
13002202 4 14
13002301 0. 14
13002400 0
13002401 1010. 5
13002402 937. 6
13002403 864. 7
13002404 791. 8
13002405 718. 9
13002406 645. 10
13002407 572. 11
13002408 499. 12
13002409 426. 13
13002410 353. 14
13002411 315. 15
13002501 300010000 10000 1 1 0.150 2
13002502 300030000 10000 1 1 0.16363 13
13002503 300140000 10000 1 1 0.130 14
13002601 -200 0 4301 1 0.150 2
13002602 -200 0 4301 1 0.16363 13
13002603 -200 0 4301 1 0.130 14
13002701 0 0. 0. 0. 14
13002801 0.001 15. 15. 0. 0. 0. 0. 1. 14
13002901 0. 15. 15. 0. 0. 0. 0. 1. 14

*

*

* Tubo G rivestimento esterno parte prima L=1.01 m, S(acciaio)=9.52 mm, S(isolante)=160 mm

*

13101000 1 13 2 1 0.06098
13101100 0 2
13101101 4.76e-3 2
13101102 0.016 12
13101201 1 2
13101202 4 12
13101301 0. 12
13101400 0
13101401 1010. 3

13101402 937. 4
13101403 864. 5
13101404 791. 6
13101405 718. 7
13101406 645. 8
13101407 572. 9
13101408 499. 10
13101409 426. 11
13101410 353. 12
13101411 315. 13
13101501 310010000 0 1 1 1.01 1
13101601 -200 0 4300 1 1.01 1
13101701 0 0. 0. 0. 1
13101801 0. 15. 15. 0. 0. 0. 0. 1. 1
13101901 0. 15. 15. 0. 0. 0. 0. 1. 1

*

*

* Tubo G rivestimento esterno parte seconda L=4.284 m, S(acciaio)=9.52 mm, S(isolante)=160 mm

*

13201000 4 13 2 1 0.06098
13201100 0 2
13201101 4.76e-3 2
13201102 0.016 12
13201201 1 2
13201202 4 12
13201301 0. 12
13201400 0
13201401 1010. 3
13201402 937. 4
13201403 864. 5
13201404 791. 6
13201405 718. 7
13201406 645. 8
13201407 572. 9
13201408 499. 10
13201409 426. 11
13201410 353. 12
13201411 315. 13
13201501 320010000 10000 1 1 1.071 4
13201601 -200 0 4300 1 1.071 4
13201701 0 0. 0. 0. 4
13201801 0. 15. 15. 0. 0. 0. 0. 1. 4
13201901 0. 15. 15. 0. 0. 0. 0. 1. 4

*

*

* Tubo G rivestimento esterno parte terza L=0.678 m, S(acciaio)=9.52 mm, S(isolante)=160 mm

*

*

13251000 1 13 2 1 0.06097
13251100 0 2
13251101 4.76e-3 2
13251102 0.016 12
13251201 1 2
13251202 5 12
13251301 0. 12
13251400 0
13251401 1010. 3

13251402 937. 4
13251403 864. 5
13251404 791. 6
13251405 718. 7
13251406 645. 8
13251407 572. 9
13251408 499. 10
13251409 426. 11
13251410 353. 12
13251411 315. 13
13251501 325010000 0 1 1 0.678 1
13251601 -200 0 4300 1 0.678 1
13251701 0 0. 0. 0. 1
13251801 0. 15. 15. 0. 0. 0. 0. 1. 1
13251901 0. 15. 15. 0. 0. 0. 0. 1. 1

*

*

* Rivestimento Sezione test imbocco

*

* L=0.695 m, S(acciaio)=7.62 mm, S(isolante)=160 mm

*

13301000 1 13 2 1 0.03683
13301100 0 2
13301101 3.81e-3 2
13301102 0.016 12
13301201 1 2
13301202 5 12
13301301 0. 12
13301400 0
13301401 1010. 3
13301402 937. 4
13301403 864. 5
13301404 791. 6
13301405 718. 7
13301406 645. 8
13301407 572. 9
13301408 499. 10
13301409 426. 11
13301410 353. 12
13301411 315. 13
13301501 330010000 0 1 1 0.695 1
13301601 -200 0 4300 1 0.695 1
13301701 0 0. 0. 0. 1
13301801 0. 15. 15. 0. 0. 0. 0. 1. 1
13301901 0. 15. 15. 0. 0. 0. 0. 1. 1

*

*

* Rivestimento Sezione test anello (Ltot=3.74); tre strutture

*

* Prima struttura: Raggio interno= 0.05165 m, L= 0.431 m, S (acciaio)= 19 mm, S(isolante)=160 mm

*

13401000 2 15 2 1 0.05165
13401100 0 2
13401101 4.75e-3 4
13401102 0.016 14
13401201 1 4
13401202 5 14
13401301 0. 14

13401400 0
13401401 1010. 3
13401402 937. 4
13401403 864. 5
13401404 791. 6
13401405 718. 7
13401406 645. 8
13401407 572. 9
13401408 499. 10
13401409 426. 11
13401410 353. 12
13401411 315. 13
13401412 315. 15
13401501 340010000 0 1 1 0.105 1
13401502 340020000 0 1 1 0.326 2
13401601 -200 0 4300 1 0.105 1
13401602 -200 0 4300 1 0.326 2
13401701 0 0. 0. 0. 2
13401801 0. 15. 15. 0. 0. 0. 0. 1. 2
13401901 0. 15. 15. 0. 0. 0. 0. 1. 2

*

* Seconda struttura: Raggio interno= 0.03326 m, L= 0.155 m, S (acciaio)= 37.39 mm, S(isolante)=160 mm

*

13402000 1 19 2 1 0.03326
13402100 0 2
13402101 4.673e-3 8
13402102 0.016 18
13402201 1 8
13402202 5 18
13402301 0. 18
13402400 0
13402401 1010. 3
13402402 937. 4
13402403 864. 5
13402404 791. 6
13402405 718. 7
13402406 645. 8
13402407 572. 9
13402408 499. 10
13402409 426. 11
13402410 353. 12
13402411 315. 13
13402412 315. 19
13402501 340010000 0 1 1 0.155 1
13402601 -200 0 4300 1 0.155 1
13402701 0 0. 0. 0. 1
13402801 0. 15. 15. 0. 0. 0. 0. 1. 1
13402901 0. 15. 15. 0. 0. 0. 0. 1. 1

*

* Terza struttura

* Raggio interno= 0.03683 m, Ltot= 3.154 m, Sequivalente (acciaio)= 11.00 mm, S(isolante)=160 mm

* La struttura comprende le due flange inferiori

*

13403000 15 14 2 1 0.03683
13403100 0 2
13403101 3.666e-3 3
13403102 0.016 13

13403201 1 3
13403202 5 13
13403301 0. 13
13403400 0
13403401 1010. 3
13403402 937. 4
13403403 864. 5
13403404 791. 6
13403405 718. 7
13403406 645. 8
13403407 572. 9
13403408 499. 10
13403409 426. 11
13403410 353. 12
13403411 315. 13
13403412 315. 14
13403501 340010000 0 1 1 0.140 1
13403502 340020000 10000 1 1 0.200 5
13403503 340060000 10000 1 1 0.2214 15
13403601 -200 0 4300 1 0.140 1
13403602 -200 0 4300 1 0.200 5
13403603 -200 0 4300 1 0.2214 15
13403701 0 0. 0. 0. 15
13403801 0. 15. 15. 0. 0. 0. 0. 1. 15
13403901 0. 15. 15. 0. 0. 0. 0. 1. 15

*

*

* SEZIONE TEST tubo interno: 2 strutture, Ltot=3.74 m

* Prima struttura

* L=3.154m, diametro interno = 0.04116m, S(acciaio)=5.54 mm, Diametro termico=0.0336

*

13601000 15 7 2 1 0.02058
13601100 0 1
13601101 2 0.02335
13601102 2 0.02660
13601103 2 0.02937
13601201 1 2
13601202 8 4 * GAP DI ELIO
13601203 1 6
13601301 0. 6
13601400 -1
13601401 1039. 1039. 1039. 1039. 1039. 1039. 1039.
13601402 1039. 1039. 1039. 1039. 1039. 1039. 1039.
13601403 1039. 1039. 1039. 1039. 1039. 1039. 1039.
13601404 1039. 1039. 1039. 1039. 1039. 1039. 1039.
13601405 1039. 1039. 1039. 1039. 1039. 1039. 1039.
13601406 1039. 1039. 1039. 1039. 1039. 1039. 1039.
13601407 1039. 1039. 1039. 1039. 1039. 1039. 1039.
13601408 1039. 1039. 1039. 1039. 1039. 1039. 1039.
13601409 1039. 1039. 1039. 1039. 1039. 1039. 1039.
13601410 1039. 1039. 1039. 1039. 1039. 1039. 1039.
13601411 1039. 1039. 1039. 1039. 1039. 1039. 1039.
13601412 1039. 1039. 1039. 1039. 1039. 1039. 1039.
13601413 1039. 1039. 1039. 1039. 1039. 1039. 1039.
13601414 1039. 1039. 1039. 1039. 1039. 1039. 1039.
13601415 1039. 1039. 1039. 1039. 1039. 1039. 1039.
13601501 360010000 10000 1 1 0.2214 10
13601502 360110000 10000 1 1 0.20 14

```

13601503 360150000      0 1 1 0.14  15
13601601 340180000 -10000 1 1 0.2214 10
13601602 340080000 -10000 1 1 0.20  14
13601603 340040000      0 1 1 0.14  15
13601701 0  0. 0. 0. 15
13601801 0.0 15. 15. 0. 0. 0. 0. 1. 10 * usato il Diametro termico per
anuli (MA SOLO SULLA PARETE ESTERNA)
13601802 0.  15. 15. 0. 0. 0. 0. 1. 15
13601901 0.0336 15. 15. 0. 0. 0. 0. 1. 10
13601902 0.0336 15. 15. 0. 0. 0. 0. 1. 15
*
* seconda struttura
* L=0.586m, diametro interno = 0.04116m, S(acciaio)=2.77 mm, Diametro
termico=0.048 m- 0.181
*
13602000 3 3 2 1 0.02058
13602100 0 1
13602101 2 0.02335
13602201 1 2
13602301 0. 2
13602400 -1
13602401 1039. 1039. 1039.
13602402 1039. 1039. 1039.
13602403 1039. 1039. 1039.
13602501 360160000      0 1 1 0.155  1
13602502 360170000      0 1 1 0.326  2
13602503 360180000      0 1 1 0.14  3
13602601 340030000      0 1 1 0.155  1
13602602 340020000      0 1 1 0.326  2
13602603 340010000      0 1 1 0.14  3
13602701 0  0. 0. 0. 3
13602801 0.0 15. 15. 0. 0. 0. 0. 1. 1 * (Anuli solo sulla parete esterna)
13602802 0.0 15. 15. 0. 0. 0. 0. 1. 2 *
13602803 0.0 15. 15. 0. 0. 0. 0. 1. 3 *
13602901 0.0480 15. 15. 0. 0. 0. 0. 1. 1
13602902 0.0845 15. 15. 0. 0. 0. 0. 1. 2
13602903 0.1810 15. 15. 0. 0. 0. 0. 1. 3
*
*-----
---
* 6 bacchette di MgO, De=9.5 mm, rivestimento di un fodero di acciaio S=1
mm
*
* Ltot=2220 mm, Lscaldante=2000 mm, Ptermica=300 kwatt (teorica 350 kw)
*
* 10 elementi con 15 punti di calcolo
*
13603000 10 14 2 1 0.
13603100 0 2
*13603101 3.75e-04 2
*13603102 3.0e-04 12
*13603103 5.0e-04 14
13603101 4.0e-05 5
13603102 3.5e-04 11
13603103 6.0e-04 13
*
13603201 3 5
13603202 6 11
13603203 7 13

```

 Ricerca Sistema Elettrico	Sigla di identificazione	Rev.	Distrib.	Pag.	di
	NNFISS – LP3 - 002	0	L	98	134

13603301 0. 5
13603302 1. 7
13603303 0. 13
*
13603400 0
13603401 1039. 14
13603501 0 0 0 0 0. 10
13603601 360010000 10000 1 1 1.332 10 * 1.554x6/7
13603701 150 0.111 0. 0. 9
13603702 0 0. 0. 0. 10
13603901 0.01 15. 15. 0. 0. 0. 0. 1. 10 * 0.0241 valore originale
ANSALDO
*
*
* 1 bacchette di MgO, De=9.5 mm, rivestimento di un fodero di acciaio S=1 mm
*
* Ltot=2220 mm, Lscaldante=2000 mm, Ptermica=300 kwatt (teorica 350 kw)
*
* 10 elementi con 15 punti di calcolo
*
13604000 10 14 2 1 0.
13604100 0 2
*13604101 3.75e-04 2
*13604102 3.0e-04 12
*13604103 5.0e-04 14
13604101 4.0e-05 5
13604102 3.5e-04 11
13604103 6.0e-04 13
*
13604201 3 5
13604202 6 11
13604203 7 13
13604301 0. 5
13604302 1. 7
13604303 0. 13
*
13604400 0
13604401 1039. 14
13604501 0 0 0 0 0. 10
13604601 360010000 10000 1 1 0.222 10 * 0.1.544x1/7
13604701 151 0.111 0. 0. 9
13604702 0 0. 0. 0. 10
13604901 0.0093 15. 15. 0. 0. 0. 0. 1. 10 * 0.0241 valore originale
ANSALDO
*
*
* Sezione test ultimo tratto verticale rivestimento esterno
* Due strutture, Ltot = 1.101 m
*
* Prima struttura
* L=0.672 m, , Diametro interno=0.04116, Sequivalente(acciaio)=35.2 mm, S(isolante)=160 mm
* La struttura comprende due flange e raccordi
*
13651000 1 21 2 1 0.02058
13651100 0 2
13651101 3.52e-3 10
13651102 0.016 20

13651201 1 10
13651202 5 20
13651301 0. 20
13651400 0
13651401 1010. 3
13651402 937. 4
13651403 864. 5
13651404 791. 6
13651405 718. 7
13651406 645. 8
13651407 572. 9
13651408 499. 10
13651409 426. 11
13651410 353. 12
13651411 315. 21
13651501 365010000 0 1 1 0.672 1
13651601 -200 0 4300 1 0.672 1
13651701 0 0. 0. 0. 1
13651801 0. 15. 15. 0. 0. 0. 0. 1. 1
13651901 0. 15. 15. 0. 0. 0. 0. 1. 1

*

* Seconda struttura

* L=0.429 m, , Diametro interno=0.07366, S(acciaio)=7.62 mm,
S(isolante)=160 mm

*

13671000 1 13 2 1 0.03683
13671100 0 2
13671101 3.81e-3 2
13671102 0.016 12
13671201 1 2
13671202 5 12
13671301 0. 12
13671400 0
13671401 1010. 3
13671402 937. 4
13671403 864. 5
13671404 791. 6
13671405 718. 7
13671406 645. 8
13671407 572. 9
13671408 499. 10
13671409 426. 11
13671410 315. 13
13671501 367010000 0 1 1 0.429 1
13671601 -200 0 4300 1 0.429 1
13671701 0 0. 0. 0. 1
13671801 0. 15. 15. 0. 0. 0. 0. 1. 1
13671901 0. 15. 15. 0. 0. 0. 0. 1. 1

*

*

* SEzione test sbocco rivestimento esterno

*

* L=0.561 m, Diametro interno=0.07366 m, S(acciaio)=7.62 mm,
S(isolante)=160 mm

*

13701000 1 13 2 1 0.03683
13701100 0 2
13701101 3.81e-3 2
13701102 0.016 12

13701201 1 2
13701202 5 12
13701301 0. 12
13701400 0
13701401 1010. 3
13701402 937. 4
13701403 864. 5
13701404 791. 6
13701405 718. 7
13701406 645. 8
13701407 572. 9
13701408 499. 10
13701409 426. 11
13701410 353. 12
13701411 315. 13
13701501 370010000 0 1 1 0.561 1
13701601 -200 0 4300 1 0.561 1
13701701 0 0. 0. 0. 1
13701801 0. 15. 15. 0. 0. 0. 0. 1. 1
13701901 0. 15. 15. 0. 0. 0. 0. 1. 1
*
*
* SEzione test plenum rivestimento esterno
*
* L=0.0875 m, S(acciaio)=7.62 mm, S(isolante)=160 mm
*
13702000 1 13 2 1 0.03683
13702100 0 2
13702101 3.81e-3 2
13702102 0.016 12
13702201 1 2
13702202 5 12
13702301 0. 12
13702400 0
13702401 1010. 3
13702402 937. 4
13702403 864. 5
13702404 791. 6
13702405 718. 7
13702406 645. 8
13702407 572. 9
13702408 499. 10
13702409 426. 11
13702410 353. 12
13702411 315. 13
13702501 352010000 0 1 1 0.0875 1
13702601 -200 0 4300 1 0.0875 1
13702701 0 0. 0. 0. 1
13702801 0. 15. 15. 0. 0. 0. 0. 1. 1
13702901 0. 15. 15. 0. 0. 0. 0. 1. 1
*
*
* SEzione test plenum rivestimento esterno
*
* L=0.127 m, S(acciaio)=7.62 mm, S(isolante)=160 mm
*
13703000 1 13 2 1 0.04898
13703100 0 2
13703101 3.81e-3 2

13703102 0.016 12
13703201 1 2
13703202 5 12
13703301 0. 12
13703400 0
13703401 1010. 3
13703402 937. 4
13703403 864. 5
13703404 791. 6
13703405 718. 7
13703406 645. 8
13703407 572. 9
13703408 499. 10
13703409 426. 11
13703410 353. 12
13703411 315. 13
13703501 352010000 0 1 1 0.127 1
13703601 -200 0 4300 1 0.127 1
13703701 0 0. 0. 0. 1
13703801 0. 15. 15. 0. 0. 0. 0. 1. 1
13703901 0. 15. 15. 0. 0. 0. 0. 1. 1
*
* SEzione test plenum rivestimento esterno
*
* L=0.485 m, S(acciaio)=7.62 mm, S(isolante)=160 mm
*
13704000 1 13 2 1 0.06113
13704100 0 2
13704101 3.81e-3 2
13704102 0.016 12
13704201 1 2
13704202 5 12
13704301 0. 12
13704400 0
13704401 1010. 3
13704402 937. 4
13704403 864. 5
13704404 791. 6
13704405 718. 7
13704406 645. 8
13704407 572. 9
13704408 499. 10
13704409 426. 11
13704410 353. 12
13704411 315. 13
13704501 352010000 0 1 1 0.485 1
13704601 -200 0 4300 1 0.485 1
13704701 0 0. 0. 0. 1
13704801 0. 15. 15. 0. 0. 0. 0. 1. 1
13704901 0. 15. 15. 0. 0. 0. 0. 1. 1
*
* Tubo A rivestimento esterno parte prima L=1.334 m, S(acciaio)=9.52 mm,
S(isolante)=160 mm
*
13801000 2 13 2 1 0.06098
13801100 0 2
13801101 4.76e-3 2
13801102 0.016 12
13801201 1 2

13801202 5 12
13801301 0. 12
13801400 0
13801401 1010. 3
13801402 937. 4
13801403 864. 5
13801404 791. 6
13801405 718. 7
13801406 645. 8
13801407 572. 9
13801408 499. 10
13801409 426. 11
13801410 353. 12
13801411 315. 13
13801501 380010000 10000 1 1 0.667 2
13801601 -200 0 4300 1 0.667 2
13801701 0 0. 0. 0. 2
13801801 0. 15. 15. 0. 0. 0. 0. 1. 2
13801901 0. 15. 15. 0. 0. 0. 0. 1. 2
*
*
* Tubo A rivestimento esterno parte seconda L=1.02 m, S(acciaio)=9.52 mm, S(isolante)=160 mm
*
13901000 2 13 2 1 0.06098
13901100 0 2
13901101 4.76e-3 2
13901102 0.016 12
13901201 1 2
13901202 5 12
13901301 0. 12
13901400 0
13901401 1010. 3
13901402 937. 4
13901403 864. 5
13901404 791. 6
13901405 718. 7
13901406 645. 8
13901407 572. 9
13901408 499. 10
13901409 426. 11
13901410 353. 12
13901411 315. 13
13901501 390010000 10000 1 1 0.510 2
13901601 -200 0 4300 1 0.510 2
13901701 0 0. 0. 0. 2
13901801 0. 15. 15. 0. 0. 0. 0. 1. 2
13901901 0. 15. 15. 0. 0. 0. 0. 1. 2
*
*
* Tubo B rivestimento esterno parte prima L=2.008 m, S(acciaio)=8.56 mm, S(isolante)=100 mm
*
14201000 4 13 2 1 0.04844
14201100 0 2
14201101 4.28e-3 2
14201102 0.01 12
14201201 1 2
14201202 2 12

14201301 0. 12
14201400 0
14201401 554. 3
14201402 527. 4
14201403 500. 5
14201404 473. 6
14201405 446. 7
14201406 419. 8
14201407 392. 9
14201408 365. 10
14201409 338. 11
14201410 311. 12
14201411 392. 13
14201501 420010000 10000 1 1 0.502 4
14201601 -200 0 4300 1 0.502 4
14201701 0 0. 0. 0. 4
14201801 0. 15. 15. 0. 0. 0. 0. 1. 4
14201901 0. 15. 15. 0. 0. 0. 0. 1. 4

*
*

* Tubo B rivestimento esterno parte seconda L=1.718 m, S(acciaio)=8.56 mm,
S(isolante)=100 mm

*

14301000 1 13 2 1 0.04844
14301100 0 2
14301101 4.28e-3 2
14301102 0.01 12
14301201 1 2
14301202 2 12
14301301 0. 12
14301400 0
14301401 554. 3
14301402 527. 4
14301403 500. 5
14301404 473. 6
14301405 446. 7
14301406 419. 8
14301407 392. 9
14301408 365. 10
14301409 338. 11
14301410 311. 12
14301411 392. 13
14301501 430010000 0 1 1 1.718 1
14301601 -200 0 4300 1 1.718 1
14301701 0 0. 0. 0. 1
14301801 0. 15. 15. 0. 0. 0. 0. 1. 1
14301901 0. 15. 15. 0. 0. 0. 0. 1. 1

*
*

* Modifica Ansaldo 08/02/2008 S =9.52 mm
* Tubo B rivestimento esterno parte terza L=2.62 m, S(acciaio)=8.56 mm,
S(isolante)=100 mm

*

14401000 2 13 2 1 0.04844
14401100 0 2
14401101 4.76e-3 2
14401102 0.01 12
14401201 1 2
14401202 2 12

14401301 0. 12
14401400 0
14401401 554. 3
14401402 527. 4
14401403 500. 5
14401404 473. 6
14401405 446. 7
14401406 419. 8
14401407 392. 9
14401408 365. 10
14401409 338. 11
14401410 311. 12
14401411 392. 13
14401501 440010000 10000 1 1 1.31 2
14401601 -200 0 4300 1 1.31 2
14401701 0 0. 0. 0. 2
14401801 0. 15. 15. 0. 0. 0. 0. 1. 2
14401901 0. 15. 15. 0. 0. 0. 0. 1. 2
*
*
* Ltot=22*11 m, S(acciaio)=1.6 mm
*
* Struttura termica aerotermo
*
14601000 11 15 2 1 0.00905
14601100 0 1
14601101 14 0.01065
14601201 1 14
14601301 1. 14
14601400 0
14601401 373. 15
14601501 460020000 10000 3400 1 22.0 11
14601601 -500 0 1000 1 22.0 11
14601701 0 0. 0. 0. 11
14601801 0. 15. 15. 0. 0. 0. 0. 1. 11
14601901 0. 15. 15. 0. 0. 0. 0. 1. 11
*
*
* Tubo C rivestimento esterno parte prima L=2.35 m, S(acciaio)=8.56 mm,
S(isolante)=60 mm
*
14801000 5 9 2 1 0.04844
14801100 0 2
14801101 4.28e-3 2
14801102 0.01 8
14801201 1 2
14801202 2 8
14801301 0. 8
14801400 0
14801401 373. 3
14801402 358. 4
14801403 343. 5
14801404 328. 6
14801405 313. 7
14801406 298. 8
14801407 288. 9
14801501 480010000 10000 1 1 0.47 5
14801601 -200 0 4300 1 0.47 5
14801701 0 0. 0. 0. 5

14801801 0. 15. 15. 0. 0. 0. 0. 1. 5
14801901 0. 15. 15. 0. 0. 0. 0. 1. 5

*
*

* Tubo C rivestimento esterno parte seconda L=1.1 m, S(acciaio)=3.91 mm,
S(isolante)=60 mm

*

14802000 4 9 2 1 0.02624
14802100 0 2
14802101 1.955e-3 2
14802102 0.01 8
14802201 1 2
14802202 2 8
14802301 0. 8
14802400 0
14802401 373. 3
14802402 358. 4
14802403 343. 5
14802404 328. 6
14802405 313. 7
14802406 298. 8
14802407 288. 9
14802501 480060000 10000 1 1 0.275 4
14802601 -200 0 4300 1 0.275 4
14802701 0 0. 0. 0. 4
14802801 0. 15. 15. 0. 0. 0. 0. 1. 4
14802901 0. 15. 15. 0. 0. 0. 0. 1. 4

*

* Struttura termica riciclo

*

*12571000 1 5 2 1 0.015
*12571100 0 1
*12571101 4 0.0165
*12571201 1 4
*12571301 1. 4
*12571400 0
*12571401 352.66 5
*12571501 257010000 10000 3400 1 22.0 1
*12571601 -600 0 1000 1 22.0 1
*12571701 0 0. 0. 0. 1
*12571801 0. 15. 15. 0. 0. 0. 0. 1. 1
*12571901 0. 15. 15. 0. 0. 0. 0. 1. 1

*

*-----
* materials tables
*-----

*

20100100 tbl/fctn 1 1 * s-steel

*

* Stainless Steel 316 conductivity k (w/m/K)

*

20100101 253. 13.223
20100102 323. 14.322
20100103 353. 14.793
20100104 373. 15.108
20100105 473. 16.679
20100106 573. 18.249
20100107 673. 19.821
20100108 773. 21.392

20100109 873. 22.963
20100110 973. 24.534
20100111 1973. 24.534
20100112 2500. 24.534

*

* Stainless Steel 316 heat capacity rocp (j/m3/K)

*

20100151 253. 4.02e3
20100152 323. 4.09e3
20100153 353. 4.12e3
20100154 373. 4.14e3
20100155 473. 4.20e3
20100156 573. 4.25e3
20100157 673. 4.28e3
20100158 773. 4.31e3
20100159 873. 4.34e3
20100160 973. 4.39e3
20100161 1973. 4.39e3
20100162 2500. 4.39e3

*

*

20100200 tbl/fctn 1 1 * rockwool1

*

* rockwool conductivity k (w/m/K)

*

*

20100201 273. 0.035
20100202 423. 0.05
20100203 573. 0.075
20100204 723. 0.10
20100205 873. 0.125
20100206 2500. 0.125

*

*

* rockwool heat capacity rocp (j/m3/K)

*

20100251 253. 0.615e3
20100252 323. 0.615e3
20100253 353. 0.615e3
20100254 373. 0.615e3
20100255 473. 0.615e3
20100256 573. 0.615e3
20100257 673. 0.615e3
20100258 773. 0.615e3
20100259 873. 0.615e3
20100260 973. 0.615e3
20100261 1973. 0.615e3
20100262 2500. 0.615e3

*

*

20100300 tbl/fctn 1 1 * ossido di magnesio

*

* ossido di magnesio k (w/m/K)

*

20100301 253. 2.077
20100302 323. 2.077
20100303 353. 2.077
20100304 373. 2.077
20100305 473. 2.077

20100306 573. 2.077
20100307 673. 2.077
20100308 773. 2.077
20100309 873. 2.077
20100310 973. 2.077
20100311 1973. 2.077
20100312 2500. 2.077

*

* ossido di magnesio rocp (j/m3/K)

*

20100351 253. 2.681e3
20100352 323. 2.681e3
20100353 353. 2.681e3
20100354 373. 2.681e3
20100355 473. 2.681e3
20100356 573. 2.681e3
20100357 673. 2.681e3
20100358 773. 2.681e3
20100359 873. 2.681e3
20100360 973. 2.681e3
20100361 1973. 2.681e3
20100362 2500. 2.681e3

*

*

20100400 tbl/fctn 1 1 * Isolante resistori

*

* dummy conductivity k (w/m/K)

*

20100401 253. 0.2
20100402 2500. 0.2

*

*

* Rockwool heat capacity rocp (j/m3/K)

*

20100451 253. 0.615e3
20100452 323. 0.615e3
20100453 353. 0.615e3
20100454 373. 0.615e3
20100455 473. 0.615e3
20100456 573. 0.615e3
20100457 673. 0.615e3
20100458 773. 0.615e3
20100459 873. 0.615e3
20100460 973. 0.615e3
20100461 1973. 0.615e3
20100462 2500. 0.615e3

*

20100500 tbl/fctn 1 1 * Isolante TS

*

* dummy conductivity k (w/m/K)

*

*

20100501 273. 0.2275
20100502 423. 0.325
20100503 573. 0.4875
20100504 723. 0.65
20100505 873. 0.677
20100506 2500. 0.8125

*

 Ricerca Sistema Elettrico	Sigla di identificazione	Rev.	Distrib.	Pag.	di
	NNFISS – LP3 - 002	0	L	108	134

*

* Rockwool heat capacity rocp (j/m3/K)

*

20100551 253. 0.615e3
20100552 323. 0.615e3
20100553 353. 0.615e3
20100554 373. 0.615e3
20100555 473. 0.615e3
20100556 573. 0.615e3
20100557 673. 0.615e3
20100558 773. 0.615e3
20100559 873. 0.615e3
20100560 973. 0.615e3
20100561 1973. 0.615e3
20100562 2500. 0.615e3

*

20100600 tbl/fctn 1 1 * Nitruro di Boro (TS pin)

*

20100601 253. 30.
20100602 2500. 30.

*

20100651 253. 3.059e3
20100652 2500. 3.059e3

*

20100700 tbl/fctn 1 1 * Ni-Cr-Fe Alloy (TS pin)

*

20100701 253. 12.456
20100702 373. 12.456
20100703 1143. 25.085
20100704 2500. 25.085

*

20100751 253. 4.1e3
20100752 2500. 4.1e3

*

20100800 tbl/fctn 1 1 * Gap Elio (conducibilità termica elio x5 per tener conto di un accoppiamento termico debole, x25 forte)

*

* conductivity k (w/m/K)

*

20100801 253. 0.9864
20100802 573. 0.9864
20100803 673. 1.108
20100804 773. 1.2216
20100805 2500. 1.2216

*

* heat capacity rocp (j/m3/K)

*

20100851 253. 5.20e3
20100852 2500. 5.20e3

*

*

20100900 tbl/fctn 1 1 * Isolante economizzatore

*

* dummy conductivity k (w/m/K)

*

20100901 273. 0.6475
20100902 423. 0.925
20100902 573. 1.3875
20100902 723. 1.85

20100902 873. 2.3125

20100902 2500. 2.3125

*

* Rockwool heat capacity rocp (j/m3/K)

*

20100951 253. 0.615e3

20100952 323. 0.615e3

20100953 353. 0.615e3

20100954 373. 0.615e3

20100955 473. 0.615e3

20100956 573. 0.615e3

20100957 673. 0.615e3

20100958 773. 0.615e3

20100959 873. 0.615e3

20100960 973. 0.615e3

20100961 1973. 0.615e3

20100962 2500. 0.615e3

*

*-----

* general tables

*-----

*

* Potenza del riscaldatore 1 Max 70 kw (6363.63 per il codice) attuale 0.0%

*

20210100 power 0 1. 70000.

20210101 -1. 0.0

20210102 0. 0.0

20210103 1.e6 0.0

*

*

20550100 pwhtr1 function 1. 0. 1

20550101 time 0 101

*

*

* Potenza del riscaldatore 2 Max 70 kw attuale 0.0%

*

20210200 power 0 1. 70000.

20210201 -1. 0.0

20210202 0. 0.0

20210203 50. 0.

20210204 100. 0.0

20210205 1.e6 0.0

*

20550200 pwhtr2 function 1. 0. 1

20550201 time 0 102

*

*

* Potenza del riscaldatore 3 Max 70 kw attuale 16%

* 1019.15 w per ogni struttura calda.

* sono 11 strutture scaldanti quindi 1019.15*11=11210w

*

20210300 power 0 1. 70000.

20210301 -1. 0.16

20210302 0. 0.16

20210303 50. 0.0

20210304 100. 0.0

20210305 9999. 0.0

*

20550300 pwhtr3 function 1. 0. 1

```

20550301  time 0  103
*
*
* Potenza 6 bacchette scaldanti sez. test 257 kw
*
20215000  power 0 1. 257.0e3
20215001  -1.  0.
20215002  0.  0.
20215003  50.  0.376
20215004  100.  0.376
20215005  500.  0.376
20215006  550.  0.376
20215007  1.e6  0.376
*
* Potenza 1 bacchette scaldanti sez. test 43 kw
*
20215100  power 0 1. 43.0e3
20215101  -1.  0.
20215102  0.  0.
20215103  50.  0.54
20215104  100.  0.54
20215105  500.  0.54
20215106  550.  0.54
20215107  1.e6  0.54
*
*
20555000  pwtst6 function 1. 0. 1
20555001  time 0  150
*
*
20555100  pwtst1 function 1. 0. 1
20555101  time 0  151
*
*
* 555  potenza TS
*
20555500  pwtest7  sum  1.  0.  0
20555501  0.  1.  cntrlvar 550
20555502  1.  cntrlvar 551
*
* Temperatura ambiente (Test+incertezze)
*
20220000  temp
20220001  -1.  280.
20220002  0.  280.
20220003  50.  286.16
20220004  9999.  286.16
*
*
* H di scambio ambiente esterno in convezione naturale
* (da rivedere)
* per tutti i compon. tranne gli scambiatori PR1, PR2 e PR3 e
l'economizzatore ed il vol 171
*
20230000  htc-temp
20230001  293. 10.0 *1.5  *
20230002  373. 10.0 *3.5  *
*
* H di scambio ambiente esterno in convezione naturale

```



* per gli scambiatori PR1, PR2 e PR3

*

20230100 htc-temp
20230101 293. 10.0
20230102 373. 10.0

*

* H di scambio ambiente esterno in convezione naturale

* per vol 171

*

20230200 htc-temp
20230201 293. 10.0
20230202 373. 10.0

*

* H di scambio ambiente esterno in convezione naturale

* per l'economizzatore

*

20230300 htc-temp
20230301 293. 15.0
20230302 373. 15.0

*

*-----

* Simulazione scambio areotermo Imposizione temperatura uscita

*

* coefficiente di scambio imposto scambiatore elio-aria

*

20240000 htc-t
20240001 -1. 1000.
20240002 0. 1000.
20240003 1.e6 1000.

*

* Temperatura pozzo termico (per imporre la temperatura all'uscita areotermo)

*

20250000 temp
20250001 -1. 348.16
20250002 0. 348.16
20250003 9999. 348.16

*

*

* Regolazione compressore

*-----

* controllo pompa con velocità imposta

20510000 dngiri function 1. 400. 1
20510001 time 0 601

*

20260100 temp 530
20260101 -1. 1415.
20260102 0. 1415.
20260103 9999. 1415.

*

* controllo della pompa su portata

* portata in funzione del tempo

*20260100 temp 530
*20260101 -1. 0.2255
*20260102 0. 0.2255
*20260103 50. 0.215

```

*20260104 9999. 0.215
*20260106 500. 0.138
*20260107 99999. 0.138
*
*20509900 dmflow sum 1. 0. 1
*20509901 0. 1. cntrlvar 101 -1. mflowj 150000000
*20509901 .1 -1. mflowj 150000000
*
*20510000 dngiri integral 100. 1361. 1
*20510001 cntrlvar 99
*
* portata nel circuito in funzione del tempo
*20510100 port function 1. 1. 1
*20510101 time 0 601
*
*-----
*
* Logica di regolazione della valvola by-pass economizzatore
* per imporre la temperature all'ingresso dell Test Section
*
*
20515200 constant constant 573.16
*
20515300 errt sum 0.1 0.0 1
20515301 0.0 -1. cntrlvar 152
20515302 1. tempg 310010000 *err. di temperatura inlet
TS
*
20515400 re-pi prop-int 5.0 0. 1 3 0.000 1.000
20515401 1. 0.08 cntrlvar 153
*
*
20515500 difp sum 1. 0. 1 3 -1. 1.
20515501 0.0 1. cntrlvar 154
20515502 -1. vlvarea 172
*
20515600 attbeam integral 0.05 0. 1 3 -0.0 1.0
20515601 cntrlvar 155
20515700 adder sum 1. 0. 0
20515701 0.0 1.0 cntrlvar 156 -1.0 vlvstem 172
*
542 cntrlvar 157 le null 0 -0.20e-2 n -1.
*
20505800 svlvhxc tripunit 1. 0. 1
20505801 542
*
543 cntrlvar 157 ge null 0 0.20e-2 n -1.
*
20505900 svlvhxo tripunit 1. 0. 1
20505901 543
*
*
* table #4: cvlinear
20200400 reac-t 0
20200401 0. 0.
20200402 1.500e-2 0.1
20200403 2.500e-2 0.15
20200404 4.00e-2 0.2

```

```

20200405 7.500e-2 0.3
20200406 0.13      0.4
20200407 0.2       0.5
20200408 0.295    0.6
20200409 0.4       0.7
20200410 0.535    0.8
20200411 0.725    0.9
20200412 1.       1.

```

*-----

* Control variables

*-----

* 007 differenza di temperatura aerotermo lato tubi

*

```

20500700 ecotbdt      sum      1.      0.      1
20500701 0.          1.      tempg   460010000
20500702 -1.         -1.     tempg   460130000

```

*

*

* 008 differenza di temperatura riscaldatore 1

*

*

```

20500800 riscldt      sum      1.      0.      1
20500801 0.          1.      tempg   240100000
20500802 -1.         -1.     tempg   240010000

```

*

*

* 009 differenza di temperatura riscaldatore 2

*

*

```

20500900 risc2dt      sum      1.      0.      1
20500901 0.          1.      tempg   260100000
20500902 -1.         -1.     tempg   260010000

```

*

*

* 010 differenza di temperatura riscaldatore 3

*

*

```

20501000 risc3dt      sum      1.      0.      1
20501001 0.          1.      tempg   300100000
20501002 -1.         -1.     tempg   300010000

```

*

*

* 011 potenza scambiata risc. 1

*

```

20501100 Prisc1      sum      1.      0.      0
20501101 0.          1.      q       240010000
20501102          1.      q       240020000
20501103          1.      q       240030000
20501104          1.      q       240040000
20501105          1.      q       240050000
20501106          1.      q       240060000
20501107          1.      q       240070000
20501108          1.      q       240080000
20501109          1.      q       240090000
20501110          1.      q       240100000
20501111          1.      q       240110000
20501112          1.      q       240120000
20501113          1.      q       240130000
20501114          -1.     cntrlvar 501

```



*
*
* 012 potenza scambiata risc. 2
*

		sum	1.	0.	0
20501200	Prisc2				
20501201	0.	1.	q		260010000
20501202		1.	q		260020000
20501203		1.	q		260030000
20501204		1.	q		260040000
20501205		1.	q		260050000
20501206		1.	q		260060000
20501207		1.	q		260070000
20501208		1.	q		260080000
20501209		1.	q		260090000
20501210		1.	q		260100000
20501211		1.	q		260110000
20501212		1.	q		260120000
20501213		1.	q		260130000
20501214		-1.	cntrlvar	502	

*
*
* 013 potenza scambiata risc. 3
*

		sum	1.	0.	0
20501300	Prisc3				
20501301	0.	1.	q		300010000
20501302		1.	q		300020000
20501303		1.	q		300030000
20501304		1.	q		300040000
20501305		1.	q		300050000
20501306		1.	q		300060000
20501307		1.	q		300070000
20501308		1.	q		300080000
20501309		1.	q		300090000
20501310		1.	q		300100000
20501311		1.	q		300110000
20501312		1.	q		300120000
20501313		1.	q		300130000
20501314		-1.	cntrlvar	503	

* 214 potenza scambiata economizzatore mantello

		sum	1.	0.	1
20501400	Pecoman1				
20501401	0.	1.	q		200010000
20501402		1.	q		200020000
20501403		1.	q		200030000
20501404		1.	q		200040000
20501405		1.	q		200050000
20501406		1.	q		200060000
20501407		1.	q		200070000
20501408		1.	q		200080000
20501409		1.	q		200090000
20501410		1.	q		200100000
20501411		1.	q		200110000
20501412		1.	q		200120000
20501413		1.	q		200130000
20501414		1.	q		200140000
20501415		1.	q		200150000
20501416		1.	q		200160000

20501417		1.	q	200170000
20501418		1.	q	200180000
20501419		1.	q	200190000
*				
20511400	Pecomant	sum	1.	0. 1
20511401	0.	1.	q	200200000
20511402		1.	q	200210000
20511403		1.	q	200220000
20511404		1.	q	200230000
20511405		1.	q	200240000
20511406		1.	q	200250000
20511407		1.	q	200260000
20511408		1.	q	200270000
20511409		1.	q	200280000
20511410		1.	q	200290000
20511411		1.	q	200300000
20511412		1.	q	200310000
20511413		1.	q	200320000
20511414		1.	q	200330000
20511415		1.	q	200340000
20511416		1.	q	200350000
20511417		1.	q	200360000
20511418		1.	q	200370000
20511419		1.	q	200380000
*				
20521400	Pecomant	sum	1.	0. 1
20521401	0.	1.	cntrlvar	14
20521402		1.	cntrlvar	114
*				
* 215 potenza scambiata economizzatore tubi				
*-----				
20501500	Pecotul	sum	1.	0. 1
20501501	0.	1.	q	400030000
20501502		1.	q	400040000
20501503		1.	q	400050000
20501504		1.	q	400060000
20501505		1.	q	400070000
20501506		1.	q	400080000
20501507		1.	q	400090000
20501508		1.	q	400100000
20501509		1.	q	400110000
20501510		1.	q	400120000
20501511		1.	q	400130000
20501512		1.	q	400140000
20501513		1.	q	400150000
20501514		1.	q	400160000
20501515		1.	q	400170000
20501516		1.	q	400180000
20501517		1.	q	400190000
20501518		1.	q	400200000
20501519		1.	q	400210000
*				
20511500	Pecotu2	sum	1.	0. 1
20511501	0.	1.	q	400220000
20511502		1.	q	400230000
20511503		1.	q	400240000
20511504		1.	q	400250000
20511505		1.	q	400260000
20511506		1.	q	400270000

 Ricerca Sistema Elettrico	Sigla di identificazione	Rev.	Distrib.	Pag.	di
	NNFISS – LP3 - 002	0	L	116	134

20511507		1.	q	400280000
20511508		1.	q	400290000
20511509		1.	q	400300000
20511510		1.	q	400310000
20511511		1.	q	400320000
20511512		1.	q	400330000
20511513		1.	q	400340000
20511514		1.	q	400350000
20511515		1.	q	400360000
20511516		1.	q	400370000
20511517		1.	q	400380000
20511518		1.	q	400390000
20511519		1.	q	400400000

*

*

20521500	Pecomant	sum	1.	0.	1
20521501	0.	1.	cntrlvar	15	
20521502		1.	cntrlvar	115	

*

*

*

* 016 potenza scambiata aerotermo

*

20501600	Paero	sum	1.	0.	1
20501601	0.	1.	q	460020000	
20501602		1.	q	460030000	
20501603		1.	q	460040000	
20501604		1.	q	460050000	
20501605		1.	q	460060000	
20501606		1.	q	460070000	
20501607		1.	q	460080000	
20501608		1.	q	460090000	
20501609		1.	q	460100000	
20501610		1.	q	460110000	
20501611		1.	q	460120000	

*

*

* 017 potenza scambiata bacchette scaldanti sez. test

*

20501700	Pbach	sum	1.	0.	0
20501701	0.	1.	q	360010000	
20501702		1.	q	360020000	
20501703		1.	q	360030000	
20501704		1.	q	360040000	
20501705		1.	q	360050000	
20501706		1.	q	360060000	
20501707		1.	q	360070000	
20501708		1.	q	360080000	
20501709		1.	q	360090000	
20501710		1.	q	360100000	
20501711		1.	q	360110000	
20501712		1.	q	360120000	
20501713		1.	q	360130000	
20501714		1.	q	360140000	
20501715		1.	q	360150000	
20501716		1.	q	360160000	
20501717		1.	q	360170000	
20501718		1.	q	360180000	

20501719 -1. cntrlvar 555

*

*

* 020 potenza scambiata piping verso l'esterno tratto compressore econom.
120-160

*

20502000	SUM01	sum	1.	0.	1
20502001	0.	1.	q		120010000
20502002		1.	q		120020000
20502003		1.	q		140010000
20502004		1.	q		140020000
20502005		1.	q		140030000
20502006		1.	q		140040000
20502007		1.	q		140050000
20502008		1.	q		160010000
20502009		1.	q		160020000
20502010		1.	q		160030000
20502011		1.	q		160040000
20502012		1.	q		160050000
20502013		1.	q		160060000
20502014		1.	q		160070000
20502015		1.	q		160080000
20502016		1.	q		160090000
20502017		1.	q		170010000
20502018		1.	q		173010000
20502019		1.	q		180010000
20502020		1.	q		180020000

*

*

* 021 potenza scambiata piping verso l'esterno by-pass 171-315

*

20502100	SUM1	sum	1.	0.	1
20502101	0.	1.	q		171010000
20502102		1.	q		171020000
20502103		1.	q		171030000
20502104		1.	q		171040000
20502105		1.	q		315010000
20502106		1.	q		315020000
20502107		1.	q		315030000
20502108		1.	q		315040000

*

* 022 potenza scambiata piping verso l'esterno raccordi riscaldatori 210-290

*

20502200	SUM2	sum	1.	0.	1
20502201	0.	1.	q		210010000
20502202		1.	q		220010000
20502203		1.	q		220020000
20502204		1.	q		230010000
20502205		1.	q		250010000
20502206		1.	q		270010000
20502207		1.	q		280010000
20502208		1.	q		280020000
20502209		1.	q		290010000
20502210		1.	q		310010000
20502211		1.	q		320010000
20502212		1.	q		320020000
20502213		1.	q		320030000

*

*

* 023 potenza scambiata piping verso l'esterno TS inlet 310-330

*

20502300	SUM3	sum	1.	0.	1
20502301	0.	1.	q		320040000
20502302		1.	q		325010000
20502303		1.	q		330010000

*

*

* 024 potenza scambiata piping verso l'esterno 340

*

20502400	SUM4	sum	1.	0.	1
20502401	0.	1.	q		340010000
20502402		1.	q		340020000
20502403		1.	q		340030000
20502404		1.	q		340040000
20502405		1.	q		340050000
20502406		1.	q		340060000
20502407		1.	q		340070000
20502408		1.	q		340080000
20502409		1.	q		340090000
20502410		1.	q		340100000
20502411		1.	q		340110000
20502412		1.	q		340120000
20502413		1.	q		340130000
20502414		1.	q		340140000
20502415		1.	q		340150000
20502416		1.	q		340160000
20502417		1.	q		340170000
20502418		1.	q		340180000

*

* 025 potenza scambiata piping verso l'esterno TS

*

20502500	SUM5	sum	1.	0.	1
20502501	0.	1.	q		352010000
*20502502		1.	q		352020000
*20502503		1.	q		352030000
20502502		1.	q		365010000

*

*

* 026 potenza scambiata piping verso l'esterno tratto economizzatore-compressore 365-440

*

20502600	SUM6	sum	1.	0.	1
20502601	0.	1.	q		420010000
20502602		1.	q		420020000
20502603		1.	q		420030000
20502604		1.	q		420040000
20502605		1.	q		430010000
20502606		1.	q		440010000
20502607		1.	q		440020000

*

*

*

* 027 potenza scambiata piping verso l'esterno tratto areotermo-compressore 480

*

20502700	SUM7	sum	1.	0.	1
20502701	0.	1.	q		480010000

 Ricerca Sistema Elettrico	Sigla di identificazione	Rev.	Distrib.	Pag.	di
	NNFISS – LP3 - 002	0	L	119	134

```

20502702          1.      q      480020000
20502703          1.      q      480030000
20502704          1.      q      480040000
20502705          1.      q      480050000
20502706          1.      q      480060000
20502707          1.      q      480070000
20502708          1.      q      480080000
20502709          1.      q      480090000

```

*

*

* 028 potenza scambiata piping verso l'esterno tratto TS-economizzatore
367-390

*

```

20502800      SUM8      sum      1.      0.      1
20502801      0.      1.      q      367010000
20502802          1.      q      370010000
20502803          1.      q      380010000
20502804          1.      q      380020000
20502805          1.      q      390010000
20502806          1.      q      390020000

```

*

*

* 031 potenza dissipata all'esterno nell'economizzatore

```

20503100      pexecon      sum      1.      0.      1
20503101      0.      1.      cntrlvar 215
20503102          1.      cntrlvar 214

```

*

* 032 potenza dissipata all'esterno nelle resistenze

```

20503200      pexheat      sum      1.      0.      1
20503201      0.      1.      cntrlvar 011
20503202          1.      cntrlvar 012
20503203          1.      cntrlvar 013
20503204          1.      cntrlvar 022

```

*

* 033 potenza dissipata all'esterno nella TS

```

20503300      pextest      sum      1.      0.      1
20503301      0.      1.      cntrlvar 017
20503302          1.      cntrlvar 024
20503303          1.      cntrlvar 023
20503304          1.      cntrlvar 025

```

*

* 034 potenza dissipata all'esterno nelle parte fredda del loop

```

20503400      pexcold      sum      1.      0.      1
20503401      0.      1.      cntrlvar 020
20503402          1.      cntrlvar 026
20503403          1.      cntrlvar 027

```

*

*

* 030 potenza scambiata piping verso l'esterno

*

```

20503000      pext      sum      1.      0.      1
20503001      0.      1.      cntrlvar 031
20503002          1.      cntrlvar 032
20503003          1.      cntrlvar 033
20503005          1.      cntrlvar 034
20503006          1.      cntrlvar 021
20503007          1.      cntrlvar 028

```

*

* 040 Salto di pressione al compressore

```
*
20504000      DP          sum      1.      0.      1
20504001      0.            1.      p 120010000
20504002     -1.            p 480090000
*
*
20520000     t215 sum      1.      0.      1
20520001     -273.16      1.      tempg 180020000
*
20520100     t216 sum      1.      0.      1
20520101     -273.16      1.      tempg 210010000
*
20520200     t221 sum      1.      0.      1
20520201     -273.16      1.      tempg 250010000
*
20520300     t222 sum      1.      0.      1
20520301     -273.16      1.      tempg 270010000
*
20520400     t223 sum      1.      0.      1
20520401     -273.16      1.      tempg 300140000
*
20520500     t232 sum      1.      0.      1
20520501     -273.16      1.      tempg 310010000
*
20520600     t217 sum      1.      0.      1
20520601     -273.16      1.      tempg 390020000
*
20520700     t218 sum      1.      0.      1
20520701     -273.16      1.      tempg 420010000
*
20520800     t202 sum      1.      0.      1
20520801     -273.16      1.      tempg 460130000
*
20520900     t204 sum      1.      0.      1
20520901     -273.16      1.      tempg 120010000
*
20521000     ts0222 sum    1.      0.      1
20521001     -273.16      0.5    httemp 360300114
20521002           0.5    httemp 360300113
*
20521100     ts0777 sum    1.      0.      1
20521101     -273.16      0.25   httemp 360300314
20521102           0.25   httemp 360300313
20521103           0.25   httemp 360300414
20521104           0.25   httemp 360300413
*
20521200     ts01221 sum   1.      0.      1
20521201     -273.16      0.25   httemp 360300514
20521202           0.25   httemp 360300513
20521203           0.25   httemp 360300614
20521204           0.25   httemp 360300613
*
20521300     ts1776 sum    1.      0.      1
20521301     -273.16      0.5    httemp 360300814
20521302           0.5    httemp 360300813
*
20531400     ts0222 sum    1.      0.      1
20531401     -273.16      0.5    httemp 360400114
20531402           0.5    httemp 360400113
```

*
20531500 ts0777 sum 1. 0. 1
20531501 -273.16 0.25 httemp 360400314
20531502 0.25 httemp 360400313
20531503 0.25 httemp 360400414
20531504 0.25 httemp 360400413
*
20521600 ts01221 sum 1. 0. 1
20521601 -273.16 0.25 httemp 360400514
20521602 0.25 httemp 360400513
20521603 0.25 httemp 360400614
20521604 0.25 httemp 360400613
*
20521700 ts1776 sum 1. 0. 1
20521701 -273.16 0.5 httemp 360400814
20521702 0.5 httemp 360400813
*
*
20522000 tswall sum 1. 0. 1
20522001 -273.16 0.5 httemp 340301503
20522002 0.5 httemp 370200103
*
20522100 tsrock sum 1. 0. 1
20522101 -273.16 1.0 httemp 365100121
*
20522300 tswall sum 1. 0. 1
20522301 -273.16 1.0 httemp 340301503
*
20522400 tswall sum 1. 0. 1
20522401 -273.16 1.0 httemp 370200103
*
20522500 t102 sum 1. 0. 1
20522501 -273.16 1. tempg 365010000
*
20523000 t215cr sum 1. 0. 1
20523001 -273.16 0.5 httemp 180100101
20523002 0.5 httemp 180100102
*
20523100 t216cr sum 1. 0. 1
20523101 -273.16 0.5 httemp 210100101
20523102 0.5 httemp 210100102
*
20523200 t217cr sum 1. 0. 1
20523201 -273.16 0.5 httemp 390100201
20523202 0.5 httemp 390100202
*
20523300 t218cr sum 1. 0. 1
20523301 -273.16 0.5 httemp 420100101
20523302 0.5 httemp 420100102
*
* 050 Regolazione del riciclo al compressore
*
*20505000 valve_ri function 1. 0. 1
*20505001 mflowj 150000000 050
*
*20505600 valfalse mult 1. 0. 1
*20505601 mflowj 256000000
*
* 041 Salto di pressione alla test section

*

20504100	DP	sum	1.	0.	1
20504101	0.	1.	p	365010000	
20504102		-1.	p	330010000	

*

*-----

*

* 064 Perdite di calore dal pre-riscaldatore 1

20506400	pr1loss	sum	1.	0.	1
20506401	0.	0.2573	htrnr	240200101	
20506402		0.3238	htrnr	240200201	
20506403		0.3238	htrnr	240200301	
20506404		0.3238	htrnr	240200401	
20506405		0.3238	htrnr	240200501	
20506406		0.3238	htrnr	240200601	
20506407		0.3238	htrnr	240200701	
20506408		0.3238	htrnr	240200801	
20506409		0.3238	htrnr	240200901	
20506410		0.3238	htrnr	240201001	
20506411		0.3238	htrnr	240201101	
20506412		0.3238	htrnr	240201201	
20506413		0.2969	htrnr	240201301	
20506414		0.2969	htrnr	240201401	

*

* 065 Perdite di calore dal pre-riscaldatore 2

20506500	pr2loss	sum	1.	0.	1
20506501	0.	0.2969	htrnr	260200101	
20506502		0.3238	htrnr	260200201	
20506503		0.3238	htrnr	260200301	
20506504		0.3238	htrnr	260200401	
20506505		0.3238	htrnr	260200501	
20506506		0.3238	htrnr	260200601	
20506507		0.3238	htrnr	260200701	
20506508		0.3238	htrnr	260200801	
20506509		0.3238	htrnr	260200901	
20506510		0.3238	htrnr	260201001	
20506511		0.3238	htrnr	260201101	
20506512		0.3238	htrnr	260201201	
20506513		0.3238	htrnr	260201301	
20506514		0.2573	htrnr	260201401	

*

* 066 Perdite di calore dal pre-riscaldatore 3

20506600	pr3loss	sum	1.	0.	1
20506601	0.	0.2969	htrnr	300200101	
20506602		0.2969	htrnr	300200201	
20506603		0.3238	htrnr	300200301	
20506604		0.3238	htrnr	300200401	
20506605		0.3238	htrnr	300200501	
20506606		0.3238	htrnr	300200601	
20506607		0.3238	htrnr	300200701	
20506608		0.3238	htrnr	300200801	
20506609		0.3238	htrnr	300200901	
20506610		0.3238	htrnr	300201001	
20506611		0.3238	htrnr	300201101	
20506612		0.3238	htrnr	300201201	
20506613		0.3238	htrnr	300201301	
20506614		0.2573	htrnr	300201401	

*

.

APPENDIX B: RELAP5 Input Deck for LOFA

```

*
=LOFA (compressor coast-down)
*
100 restart transnt
103 235684
*
* time steps                min  mj   re
*
201 700. 1.e-7  0.1    3   50  5000 5000
202 800. 1.e-7  0.01   3   50  5000 5000
203 5000. 1.e-7  0.1    3   50  5000 5000
*
* Trips
*
515 time 0 ge null 0 500. 1 * trip chiusura pressurizzatore
601 -515 and -515 n        * trip apertura pressurizzatore
*
*555 time 0 ge null 0 700. n -1. *trip apertura break
*556 p140040000 ge null 0 27.e5 n 0. * trip chiusura break
*556 time 0 le null 0 715. n 0. * trip chiusura break
*655 555 and 556 n
*656 -556 and -556 n
*
*           trip di fine calcolo
540 time 0 ge null 0 2500. 1 * end of transient
600 540
*
*
* Compressore regolato sulla velocità
*-----
*
20510000 dngiri function 1. 400. 1
20510001 time 0 601
*
20260100 temp 530
20260101 -1. 1415.
20260102 0. 1415.
20260103 700. 1415.
20260104 750. 890.
20260105 1500. 890.
20260106 5000. 890.
*20260104 750. 1046.
*20260105 1500. 1046.
*20260106 5000. 1046.
*
*
* real thermal capacity restored
*-----
* materials tables
*-----
*
20100100 tbl/fctn 1 1 * s-steel
*
* Stainless Steel 316 conductivity k (w/m/K)
*
20100101 253. 13.223

```

20100102 323. 14.322
20100103 353. 14.793
20100104 373. 15.108
20100105 473. 16.679
20100106 573. 18.249
20100107 673. 19.821
20100108 773. 21.392
20100109 873. 22.963
20100110 973. 24.534
20100111 1973. 24.534
20100112 2500. 24.534

*

* Stainless Steel 316 heat capacity rocp (j/m3/K)

*

20100151 253. 4.02e6
20100152 323. 4.09e6
20100153 353. 4.12e6
20100154 373. 4.14e6
20100155 473. 4.20e6
20100156 573. 4.25e6
20100157 673. 4.28e6
20100158 773. 4.31e6
20100159 873. 4.34e6
20100160 973. 4.39e6
20100161 1973. 4.39e6
20100162 2500. 4.39e6

*

20100200 tbl/fctn 1 1 * rockwooll

*

* rockwool conductivity k (w/m/K)

*

20100201 273. 0.035
20100202 423. 0.05
20100203 573. 0.075
20100204 723. 0.10
20100205 873. 0.125
20100206 2500. 0.125

*

* rockwool heat capacity rocp (j/m3/K)

*

20100251 253. 0.615e6
20100252 2500. 0.615e6

*

20100300 tbl/fctn 1 1 * ossido di magnesio

*

* ossido di magnesio k (w/m/K)

*

20100301 253. 2.077
20100302 2500. 2.077

*

* ossido di magnesio rocp (j/m3/K)

*

20100351 253. 2.681e6
20100362 2500. 2.681e6

*

20100400 tbl/fctn 1 1 * Isolante resistori

*

* dummy conductivity k (w/m/K)

*

20100401 253. 0.27
20100402 2500. 0.27
*
* Rockwool heat capacity rocp (j/m3/K)
*
20100451 253. 0.615e6
20100462 2500. 0.615e6
*
20100500 tbl/fctn 1 1 * Isolante TS
*
* dummy conductivity k (w/m/K)
*
20100501 253. 0.25
20100502 2500. 0.25
*
* Rockwool heat capacity rocp (j/m3/K)
*
20100551 253. 0.615e6
20100562 2500. 0.615e6
*
20100600 tbl/fctn 1 1 * Nitruro di Boro (TS pin)
*
20100601 253. 30.
20100602 2500. 30.
*
20100651 253. 3.059e6
20100652 2500. 3.059e6
*
20100700 tbl/fctn 1 1 * Ni-Cr-Fe Alloy (TS pin)
*
20100701 253. 12.456
20100702 373. 12.456
20100703 1143. 25.085
20100704 2500. 25.085
*
20100751 253. 4.1e6
20100752 2500. 4.1e6
*
20100800 tbl/fctn 1 1 * Gap Elio
*
* Helium conductivity k (w/m/K)
*
20100801 253. 1.233
20100802 573. 1.233
20100803 673. 1.385
20100804 773. 1.527
20100805 2500. 1.527
*
* heat capacity rocp (j/m3/K)
*
20100851 253. 5.20e3
20100852 2500. 5.20e3
*
20100900 tbl/fctn 1 1 * Isolante economizzatore
*
* dummy conductivity k (w/m/K)
*
20100901 253. 0.65
20100902 2500. 0.65

 Ricerca Sistema Elettrico	Sigla di identificazione NNFISS – LP3 - 002	Rev. 0	Distrib. L	Pag. 126	di 134
--	---	------------------	----------------------	--------------------	------------------

*
 * Rockwool heat capacity rocp (j/m3/K)
 *
 20100951 253. 0.615e6
 20100962 2500. 0.615e6
 *
 *
 .

APPENDIX C: RELAP5 Input Deck for TOP

```

*
=TOP (Test Section Power Increase)
*
100 restart transnt
103 213453
*
* time steps                min  mj   re
*
201 700. 1.e-7  0.1    3   50  5000 5000
202 800. 1.e-7  0.01   3   50  5000 5000
203 2500. 1.e-7  0.1    3   50  5000 5000
204 4500. 1.e-7  0.1    3   100 10000 10000
*
* Trips
*
515 time 0 ge null 0 500. 1 * trip chiusura pressurizzatore
601 -515 and -515 n        * trip apertura pressurizzatore
*
*555 time 0 ge null 0 700. n -1. *trip apertura break
*556 p 140040000 ge null 0 27.e5 n 0. * trip chiusura break
*556 time 0 le null 0 715. n 0. * trip chiusura break
*655 555 and 556 n
*656 -556 and -556 n
*
*           trip di fine calcolo
540 time 0 ge null 0 5500. 1 * end of transient
600 540
*
*
* nearly istantaneous increase of power
*-----
*
* Potenza 6 bacchette scaldanti sez. test 257 kw
*
20215000 power 0 1. 257.0e3
20215001 -1. 0.
20215002 0. 0.
20215003 50. 0.282
20215004 700. 0.282
20215005 700.1 0.47
20215006 800. 0.47
20215007 1.e6 0.47
*
* Potenza 1 bacchette scaldanti sez. test 43 kw
*
20215100 power 0 1. 43.0e3
20215101 -1. 0.
20215102 0. 0.
20215103 50. 0.405
20215104 700. 0.405
20215105 700.1 0.675
20215106 800. 0.675
20215107 1.e6 0.675
*
*

```

* real thermal capacity restored

*-----

* materials tables

*-----

*

20100100 tbl/fctn 1 1 * s-steel

*

* Stainless Steel 316 conductivity k (w/m/K)

*

20100101 253. 13.223

20100102 323. 14.322

20100103 353. 14.793

20100104 373. 15.108

20100105 473. 16.679

20100106 573. 18.249

20100107 673. 19.821

20100108 773. 21.392

20100109 873. 22.963

20100110 973. 24.534

20100111 1973. 24.534

20100112 2500. 24.534

*

* Stainless Steel 316 heat capacity rocp (j/m3/K)

*

20100151 253. 4.02e6

20100152 323. 4.09e6

20100153 353. 4.12e6

20100154 373. 4.14e6

20100155 473. 4.20e6

20100156 573. 4.25e6

20100157 673. 4.28e6

20100158 773. 4.31e6

20100159 873. 4.34e6

20100160 973. 4.39e6

20100161 1973. 4.39e6

20100162 2500. 4.39e6

*

20100200 tbl/fctn 1 1 * rockwool1

*

* rockwool conductivity k (w/m/K)

*

20100201 273. 0.035

20100202 423. 0.05

20100203 573. 0.075

20100204 723. 0.10

20100205 873. 0.125

20100206 2500. 0.125

*

* rockwool heat capacity rocp (j/m3/K)

*

20100251 253. 0.615e6

20100252 2500. 0.615e6

*

20100300 tbl/fctn 1 1 * ossido di magnesio

*

* ossido di magnesio k (w/m/K)

*

20100301 253. 2.077

20100302 2500. 2.077

 Ricerca Sistema Elettrico	Sigla di identificazione	Rev.	Distrib.	Pag.	di
	NNFISS – LP3 - 002	0	L	129	134

```

*
* ossido di magnesio rocp (j/m3/K)
*
20100351 253. 2.681e6
20100362 2500. 2.681e6
*
20100400 tbl/fctn 1 1 * Isolante resistori
*
* dummy conductivity k (w/m/K)
*
20100401 253. 0.27
20100402 2500. 0.27
*
* Rockwool heat capacity rocp (j/m3/K)
*
20100451 253. 0.615e6
20100462 2500. 0.615e6
*
20100500 tbl/fctn 1 1 * Isolante TS
*
* dummy conductivity k (w/m/K)
*
20100501 253. 0.25
20100502 2500. 0.25
*
* Rockwool heat capacity rocp (j/m3/K)
*
20100551 253. 0.615e6
20100562 2500. 0.615e6
*
20100600 tbl/fctn 1 1 * Nitruro di Boro (TS pin)
*
20100601 253. 30.
20100602 2500. 30.
*
20100651 253. 3.059e6
20100652 2500. 3.059e6
*
20100700 tbl/fctn 1 1 * Ni-Cr-Fe Alloy (TS pin)
*
20100701 253. 12.456
20100702 373. 12.456
20100703 1143. 25.085
20100704 2500. 25.085
*
20100751 253. 4.1e6
20100752 2500. 4.1e6
*
20100800 tbl/fctn 1 1 * Gap Elio
*
* Helium conductivity k (w/m/K)
*
20100801 253. 1.233
20100802 573. 1.233
20100803 673. 1.385
20100804 773. 1.527
20100805 2500. 1.527
*
* heat capacity rocp (j/m3/K)

```

 Ricerca Sistema Elettrico	Sigla di identificazione NNFISS – LP3 - 002	Rev. 0	Distrib. L	Pag. 130	di 134
--	---	------------------	----------------------	--------------------	------------------

*

20100851 253. 5.20e3

20100852 2500. 5.20e3

*

20100900 tbl/fctn 1 1 * Isolante economizzatore

*

* dummy conductivity k (w/m/K)

*

20100901 253. 0.65

20100902 2500. 0.65

*

* Rockwool heat capacity rocp (j/m3/K)

*

20100951 253. 0.615e6

20100962 2500. 0.615e6

*

*

.

 Ricerca Sistema Elettrico	Sigla di identificazione	Rev.	Distrib.	Pag.	di
	NNFISS – LP3 - 002	0	L	131	134

APPENDIX D: RELAP5 Input Deck for LOCA

```

*
=LOCA (0,5 inc)
*
100 restart transnt
103 225288
*
* time steps                min  mj   re
*
201 700. 1.e-7  0.1    3   50  5000 5000
202 900. 1.e-7  0.01   3   50  5000 5000
203 5000. 1.e-7  0.1    3   50  5000 5000
*
* Trips
*
515 time 0 ge null 0 500. 1 * trip chiusura pressurizzatore
601 -515 and -515 n          * trip apertura pressurizzatore
*
555 time 0 ge null 0 700. n -1. *trip apertura break
556 time 0 le null 0 738. n 0. * trip chiusura break
655 555 and 556 n
656 -556 and -556 n
*
*           trip di fine calcolo
540 time 0 ge null 0 1500. 1 * end of transient
600 540
*
*           Valvola Simulazione Rottuta
*
1470000 bypvl2 valve
*           da           a           sez.giu(m 2) Kdir Kinv  efvcahs
1470101 140010000 148000000 1.114e-3 0. 0. 000000
*           condizioni iniziali
*           (kg/s) mliq mgas !
1470201 1 0. 0.00 0.
*           tipo valvola
1470300 mtrv1v
*           apritrip chiuditrip vel.cambio pos.iniz.
1470301 655 656 .33333 0.0
*           pos.normaliz CSUBVdir CSUBVinv
1470400 1. 0.08
*
1470401 0. 0. 0.
1470402 0.1 15.0 15.0
1470403 0.3 30.5 30.5
1470404 0.4 47.0 47.0
1470405 0.5 73.0 73.0
1470406 0.6 92.0 92.0
1470407 0.7 125.0 125.0
1470408 0.8 165.0 165.0
1470409 0.9 212.0 212.0
1470410 1.0 265.0 265.0
*
*
*           valvola manuale da 0.5 inc.
*
1490000 vlvman sngljun

```



* da a sez.giun(m 2) Kf Kr efvcahs
1490101 148010000 146000000 0.12668e-3 2.6 2.6 000000

* (kg/s) mliq mgas !
1490201 1 0.0 0.0 0.0

*
*
* real thermal capacity restored

*-----
* materials tables
*-----

*
20100100 tbl/fctn 1 1 * s-steel

*
* Stainless Steel 316 conductivity k (w/m/K)

*
20100101 253. 13.223
20100102 323. 14.322
20100103 353. 14.793
20100104 373. 15.108
20100105 473. 16.679
20100106 573. 18.249
20100107 673. 19.821
20100108 773. 21.392
20100109 873. 22.963
20100110 973. 24.534
20100111 1973. 24.534
20100112 2500. 24.534

*
* Stainless Steel 316 heat capacity rocp (j/m3/K)

*
20100151 253. 4.02e6
20100152 323. 4.09e6
20100153 353. 4.12e6
20100154 373. 4.14e6
20100155 473. 4.20e6
20100156 573. 4.25e6
20100157 673. 4.28e6
20100158 773. 4.31e6
20100159 873. 4.34e6
20100160 973. 4.39e6
20100161 1973. 4.39e6
20100162 2500. 4.39e6

*
20100200 tbl/fctn 1 1 * rockwool1

*
* rockwool conductivity k (w/m/K)

*
20100201 273. 0.035
20100202 423. 0.05
20100203 573. 0.075
20100204 723. 0.10
20100205 873. 0.125
20100206 2500. 0.125

*
* rockwool heat capacity rocp (j/m3/K)

*
20100251 253. 0.615e6
20100252 2500. 0.615e6

*

20100300 tbl/fctn 1 1 * ossido di magnesio
*
* ossido di magnesio k (w/m/K)
*
20100301 253. 2.077
20100302 2500. 2.077
*
* ossido di magnesio rocp (j/m3/K)
*
20100351 253. 2.681e6
20100362 2500. 2.681e6
*
20100400 tbl/fctn 1 1 * Isolante resistori
*
* dummy conductivity k (w/m/K)
*
20100401 253. 0.27
20100402 2500. 0.27
*
* Rockwool heat capacity rocp (j/m3/K)
*
20100451 253. 0.615e6
20100462 2500. 0.615e6
*
20100500 tbl/fctn 1 1 * Isolante TS
*
* dummy conductivity k (w/m/K)
*
20100501 253. 0.25
20100502 2500. 0.25
*
* Rockwool heat capacity rocp (j/m3/K)
*
20100551 253. 0.615e6
20100562 2500. 0.615e6
*
20100600 tbl/fctn 1 1 * Nitruro di Boro (TS pin)
*
20100601 253. 30.
20100602 2500. 30.
*
20100651 253. 3.059e6
20100652 2500. 3.059e6
*
20100700 tbl/fctn 1 1 * Ni-Cr-Fe Alloy (TS pin)
*
20100701 253. 12.456
20100702 373. 12.456
20100703 1143. 25.085
20100704 2500. 25.085
*
20100751 253. 4.1e6
20100752 2500. 4.1e6
*
20100800 tbl/fctn 1 1 * Gap Elio
*
* Helium conductivity k (w/m/K)
*
20100801 253. 1.233

 Ricerca Sistema Elettrico	Sigla di identificazione	Rev.	Distrib.	Pag.	di
	NNFISS – LP3 - 002	0	L	134	134

20100802 573. 1.233

20100803 673. 1.385

20100804 773. 1.527

20100805 2500. 1.527

*

* heat capacity rocp (j/m3/K)

*

20100851 253. 5.20e3

20100852 2500. 5.20e3

*

20100900 tbl/fctn 1 1 * Isolante economizzatore

*

* dummy conductivity k (w/m/K)

*

20100901 253. 0.65

20100902 2500. 0.65

*

* Rockwool heat capacity rocp (j/m3/K)

*

20100951 253. 0.615e6

20100962 2500. 0.615e6

*

.