



Agenzia Nazionale per le Nuove Tecnologie,
l'Energia e lo Sviluppo Economico Sostenibile



Ministero dello Sviluppo Economico

RICERCA DI SISTEMA ELETTRICO

Analysis of the external events effects in relation to the stress tests requirement

G. Forasassi, R. Lo Frano



Report RdS/2011/341

ANALYSIS OF THE EXTERNAL EVENTS EFFECTS IN RELATION TO THE STRESS TESTS
REQUIREMENTS

G. Forasassi, R. Lo Frano (Università di Pisa)

Novembre 2011

Report Ricerca di Sistema Elettrico

Accordo di Programma Ministero dello Sviluppo Economico – ENEA

Area: Governo, gestione e sviluppo del sistema elettrico nazionale

Progetto: Fissione nucleare: metodi di analisi e verifica di progetti nucleari di generazione evolutiva ad acqua pressurizzata

Responsabile Progetto: Massimo Sepielli, ENEA

Titolo

Analysis of the external events effects in relation to the stress tests requirements

Ente emittente ENEA

PAGINA DI GUARDIA

Descrittori
Tipologia del documento: Rapporto tecnico

Collocazione contrattuale: ACCORDO DI PROGRAMMA Ministero dello Sviluppo Economico – ENEA sulla Ricerca di Sistema Elettrico PIANO ANNUALE DI REALIZZAZIONE 2010 Progetto 1.3.2.a: Fissione nucleare: Metodi di analisi e verifica di progetti nucleari di generazione evolutiva ad acqua pressurizzata.

Sommario

In conseguenza dell'incidente di Fukushima sono stati previsti dalle associazioni europee ed internazionali dei "stress test", da condurre sugli impianti attuali. Di conseguenza diventa di significativa importanza la valutazione della sicurezza degli attuali e futuri impianti nucleari a fronte di condizioni avverse indotte da eventi quali quelli accaduti a Fukushima.

In questa ottica gli obiettivi dello studio sono stati:

1. valutare il comportamento sismico di un *Small Medium Reactor* innovativo colpito da un eccezionale evento sismico caratterizzato da una grandezza ben oltre il valore di base di progettazione, al fine di comprendere il vero stato di strutture, sistemi e componenti in termini di funzioni di sicurezza richieste e capacità, e di conseguenza, essere in grado di valutare correttamente il margine di sicurezza sismica degli impianti considerati;
2. determinare la risposta strutturale globale e la vulnerabilità di un edificio reattore sottoposto all'impatto di un aereo commerciale;
3. impostare un approccio metodologico applicativo per analizzare in modo ragionevole il fenomeno dello tsunami.

Nello studio sono stati considerati i reattori di piccole e medie dimensioni, attualmente in fase di sviluppo, perché sono tra i più promettenti reattori del "Nuclear Renaissance" in quanto offrono vantaggi quali: un miglioramento della sicurezza e dell'economia, tempi di realizzazione più brevi, generazione distribuita e la disponibilità per applicazioni diverse dalla generazione di energia elettrica (dissalazione. ecc.).

Note
Copia n.
In carico a:

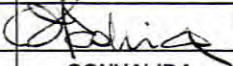
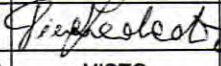
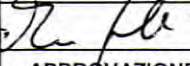
2			NOME			
			FIRMA			
1			NOME			
			FIRMA			
0	EMISSIONE	30/11/2011	NOME	Ø. Aronica	P. Incalcaterra	M. Sepielli
			FIRMA			
REV.	DESCRIZIONE	DATA	CONVALIDA	VISTO	APPROVAZIONE	



CIRTEN

Consorzio Interuniversitario per la Ricerca Tecnologica Nucleare

UNIVERSITY OF PISA

Department of Mechanical Nuclear and Production Engineering

**Analysis of the external events effects in relation to the
stress tests requirements**

AUTHORS

G. FORASASSI

R. LO FRANO

CERSE-UNUPI RL 1555/2011

PISA, Novembre 2011

Lavoro svolto in esecuzione dell'Obiettivo 4.2 Attività A2

AdP MSE-ENEA sulla Ricerca di Sistema Elettrico- Piano Annuale di Realizzazione 2010

Progetto 1.3.2.a "Fissione nucleare: Metodi di analisi e verifica di progetti nucleari di generazione evolutiva alimentati ad acqua pressurizzata"

TABLE OF CONTENTS

List of Figures..... 2

List of Tables 2

Nomenclature 3

1. Introduction..... 4

2. Reactor Modelling..... 9

3. BDBE ANALYSIS 12

3.2 Numerical Investigation..... 14

3.3 BDBE ANALYSIS RESULTS..... 16

4. AIRCRAFT IMPACT ASSESSMENT 21

4.1 RB DYNAMIC RESPONSE..... 24

4.2 MAIN AIRCRAFT CRASH ANALYSES RESULTS 25

5. TSUNAMI ASSESSMENT 32

5.1 BASIC APPROACH TO TSUNAMI ANALYSIS 34

5.2 PROPOSED APPROACH TO TSUNAMI ANALYSIS..... 39

6. CONCLUSIONS 42

REFERENCES..... 43

List of Figures

- Figures 1- Fukushima earthquake induced effects 5
- Figure 2 - IRIS RB layout 10
- Figure 3 – Seismicity map..... 12
- Figure 4 - RB FEM model..... 14
- Figures 5 - BDBE response spectra..... 15
- Figures 6 - BDBE acceleration time histories 15
- Figure 7 - Accelerations behaviour at different RB elevations 17
- Figure 8 - Displacements behaviour at different RB elevations 18
- Figure 9 - Response spectra comparison..... 19
- Figure 10 – Stress behavior inside RB 19
- Figure 11 - Von Mises stress in the RPV 20
- Figure 12 – Riera load time function, F(t) 23
- Figure 13 - Load-time function for different military (a) and civilian (b) airplanes..... 24
- Figure 14 - Entry directions in the aircraft impact analyses 25
- Figure 15 - Penetration depth vs. time for the Boeing 767 close (a) and far away (b) the impact entry A..... 26
- Figure 16 - Penetration depth at the engine impact for Eurofighter (a), Phantom (b), Boeing 747 (c) and 767 (d)..... 29
- Figure 17 - Rebar stress behavior close to the impact entry A for the Boeing 747 30
- Figure 18 - Horizontal acceleration comparison for different airplanes impact 30
- Figure 21 - Recorded tsunami event 32
- Figure 22 – “killer” tsunami event 33
- Figure 19 - Tsunami waves impinging on the 6 m protective wall of the nuclear plant..... 34
- Figure 20 - Water waves ingress at the base of the ventilation stack system 34
- Figure 23 –Processes and main associated damage modes on buildings (second wave)[13] 36
- Figure 24 – Water wave for deep and shallow depth 37
- Figure 25 – Relation between tsunami magnitude and the maximum run-up height. 38
- Figure 26 – Proposed methodology for future development..... 41

List of Tables

- Table 1** – Medium and Small Reactors [2]..... 6

Nomenclature

DOF	Degree of freedom
FEM	Finite Element Method
FRS	Floor Response Spectra
IRIS	International Reactor Innovative and Secure
NPP	Nuclear Power Plant
RB	Reactor Building
RPV	Reactor Pressure Vessel
SMR	Small Medium Reactor
SSC	Structures, Systems and Components
BDBE	Beyond Design Basis Earthquake
DFE	Design Flood Elevation

1. INTRODUCTION

The dramatic consequence of the magnitude 9.0 earthquake and 14 m tsunami in Fukushima Daiichi nuclear power plant, reactors 1, 2, 3 and 4 highlighted and confirmed that the existing and the future nuclear installations should be designed to be highly secure and capable to withstand a wide range of internal and external extreme loads, such as earthquakes, tsunamis, flooding, aircraft crash, etc. Furthermore as the recent Fukushima accident showed (Fig.1), severe external exceptional events are not impossible, even if very unlikely, and can seriously impair the safety of the nuclear facilities, if not correctly taken into account in the design phase. External events, that originate outside a NPP, may be due to natural or human induced causes or factors, therefore they must be considered for correct NPP design purposes since the site evaluation process. Among the design basis event (DBE), the most severe to be considered are:

- Earthquake
- Floods (due to tsunamis, landslides into water bodies, etc.)
- Winds (tornadoes, etc.)
- Abrasive dust and sand storms
- Lightning
- Aircraft impact
- Etc.





Figures 1- Fukushima earthquake induced effects

Licensing of nuclear power plants is regulated by the General Design Criteria for Nuclear Power Plants which requires that structures, systems, and components important to safety be designed to withstand the effects of natural and man-induced phenomena, including the mentioned earthquakes, tornado, tsunamis, etc [1]. Moreover in the light of the “stress tests”, that are at present foreseen by the European and International Associations, it becomes of meaningful importance the assessment of the aspects of nuclear plant safety and of the strength or safety margins of the existing or under development NPPs in the conditions induced by the events which occurred in Fukushima.

The stress test are comprehensive tests which embrace both natural and manmade hazards focusing on the assessment of risk related to the external events.

To guarantee the highest safety standards worldwide, taken into account the lessons learnt from Fukushima, the attention is focused in the analysis of all natural disasters considering also the effects of man-made accidents such as airplane crashes as well as terrorist or other malevolent attacks. In this light the aims of this study are:

1. to evaluate the seismic behavior of an innovative SMR hit by an exceptional seismic event, characterized by a magnitude well beyond the design basis value (e.g. also 2007 Niigataken Chuetsu-Oki or 2010 Chile earthquakes), in order to understand the true state of the SSCs in terms of their required safety functions and capacity, and, as a result, to be able to assess correctly the seismic safety margin of the considered installation;

2. to determine the global structural response and the vulnerability of a reactor building subjected to a deliberate commercial aircraft impact in the assumption of an attack from multiple entry directions.
3. to set up a methodological approach to be applied to analyze in a reasonable way the phenomenon of tsunami.

To the purpose it is important to highlight that there is a lack of studies in the available literature due to the complexity of determining the massive waves height at the site as well as the hydrodynamic force arisen during the waves elevation and their following impact on the reactor building structure.

The small and medium sized reactors (SMRs presently under development), look like IRIS or NuScale or mPower are considered because they are included among the most promising reactor concepts of the Nuclear Renaissance, offering such advantages as improved safety and economics, shorter construction times, distributed generation and availability for non-power generation applications.

The most advanced modular projects (25 MWe up) are summarized in table 1.

Table 1 – Medium and Small Reactors [2]

Name	Capacity	Type	Developer
KLT-40S	35 MWe	PWR	OKBM, Russia
VK-300	300 MWe	BWR	Atomenergoproekt, Russia
CAREM	27 MWe	PWR	CNEA & INVAP, Argentina
IRIS	100-335 MWe	PWR	Westinghouse-led, international
Westinghouse SMR	200 MWe	PWR	Westinghouse, USA
mPower	125 MWe	PWR	Babcock & Wilcox, USA
SMART	100 MWe	PWR	KAERI, South Korea
NuScale	45 MWe	PWR	NuScale Power, USA
HTR-PM	2x105 MWe	HTR	INET & Huaneng, China
PBMR	80 MWe	HTR	Eskom, South Africa
GT-MHR	285 MWe	HTR	General Atomics (USA), Rosatom

Name	Capacity	Type	Developer
			(Russia)
BREST	300 MWe	FNR	RDIPE, Russia
SVBR-100	100 MWe	FNR	Rosatom/En+, Russia
Hyperion PM	25 MWe	FNR	Hyperion, USA
Prism	311 MWe	FNR	GE-Hitachi, USA
FUJI	100 MWe	MSR	ITHMSO, Japan-Russia-USA

As it was already mentioned the proposed study the reliability of a SMR was evaluated (as well the safety margin) against the dynamic loads induced by exceptional initiating events, like:

1. Earthquakes exceeding the design basis known also as “beyond design basis earthquakes”(BDBE);
2. Other extreme external conditions challenging the specific site and leading to a severe accident;
3. Flooding exceeding the design basis one.

Particular attention has been paid to the capability of the outer containment system to withstand high dynamic loads without relevant failure/damages: generally NPPs rely in the design of their containment system that might be able to withstand dynamic impacts, arisen during floodings, earthquakes, hurricanes, aircraft impact, etc., even though they are not specifically designed for this type of loads and to remain safe.

The outer containment system, that represents that last defense barrier against an uncontrolled release of radioactivity to the environment and population, in general is characterized by thick and heavy reinforced concrete walls capable to prevent and/or reduce the unbearable damages that might be caused by these type of exceptional events.

The containment building structure, which incorporates and surrounds the main relevant and interacting nuclear system components, represents therefore the main safety barrier against radioactive leakages, “missiles” impact or against any kind of external hazards; therefore just from the early stage of the design should be analyzed taking into account, among the required criteria [1], the most important external events that should affect the safety of nuclear power plants.

In particular the attention has been paid to the effects to the effects induced by the BDBE on the overall nuclear structures, systems and components (SSCs), which should maintain their functionality, if that type of seismic event occurs.

2. REACTOR MODELLING

International Reactor Innovative and Secure (IRIS) design, used in what follows as a possible NPP example, is a smaller- scale PWR reactor that may be considered a bridge from Generation III reactor to Generation IV reactor technology. the main objective of the SMRs design is to provide a flexible, cost-effective energy alternative; in general according to the IAEA classification, Small Reactors are reactors with the equivalent electric power less than 300 MW while the Medium Sized Reactors between 300 and 700 MW, although in general anything with an output of less than 500 MWe should be accounted as a small reactor.

Small and medium sized reactors (SMRs) may provide an attractive and affordable option for many developing countries with small electrical grids, insufficient infrastructure and limited investment capability. Multi-module SMRs power plants (the term “modular” refers to a single reactor that can be grouped with other modules to form a larger nuclear power plant) may offer energy production flexibility and couple to this latter the co-generation and many advanced future process heat applications.

“Advanced SMRs have several common technology development issues related to their targeted location in the proximity to the users, competitiveness in targeted applications, enhanced proliferation resistance and security, long refuelling interval and operation without on-site refuelling”.

In SMR designs the approach is to maximize the inherent safety using reasonable combinations of active and passive safety systems in order to eliminate or prevent, as possible, accident initiators and consequences. The concepts with integral primary circuit layout include the CAREM-25 with 27 MW(e), a prototype for a series of larger capacity SMRs being developed by the CNEA (Argentina), the IRIS with 335 MW(e), being developed by the international consortium led by Westinghouse (USA), and the SCOR concept with 630 MW(e), being developed by CEA (France). The CAREM-25 and the IRIS have reached detailed design stages with deployments formerly targeted for 2011 and 2015 respectively, while the SCOR is just a conceptual design [3].

In this report, as previously mentioned, the response of the reactor building (RB) of an SMR like IRIS one has been considered, due also to the fact that the authors, as CIRTEN is concerned, participated to the reactor International development study group.

IRIS is characterized by an innovative integrated primary system design that incorporates all the main primary circuit components within the vessel. This integral configuration offers intrinsic safety design improvements as:

- With the primary coolant outside the steam generators, tubes are in compression, and tensile stress corrosion cracking is eliminated;
- The axial fully immersed pumps result in no seal leak concerns, no possibility for shaft breaks, and no required maintenance;
- The internal control rod drive mechanisms eliminates head penetrations and the possibility of penetration failures as well as the need for any future head replacements, and eliminates rod ejection accidents;
- The much larger volume/power ratio of the pressurizer provides better control of pressure transients, additionally, no sprays are required.

Although the design is not yet finalized (a 335 MW output has been proposed, but it could be tweaked to be as low as a 100 MW unit), a possible layout could be the one represented in Fig. 3 [4].

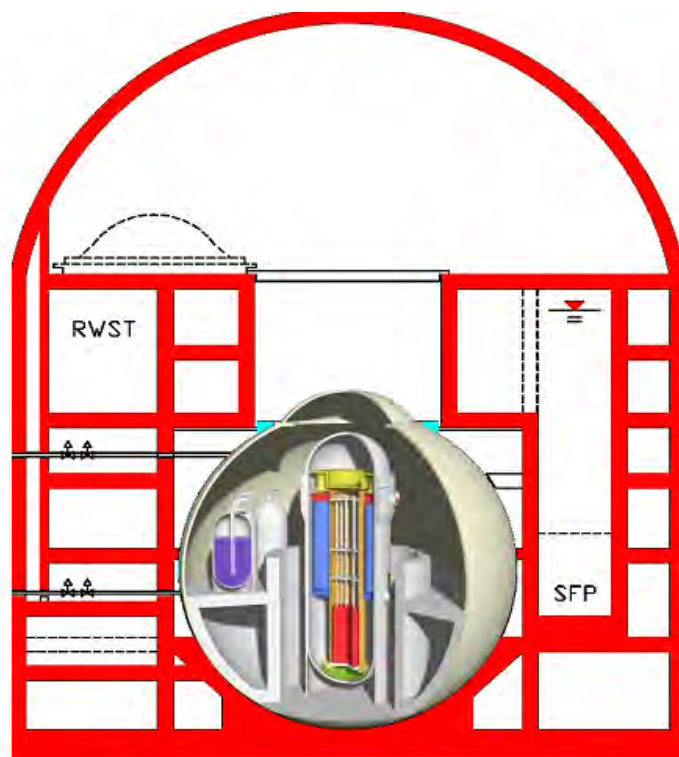

Figure 2 - IRIS RB layout

To evaluate the effects of a beyond design basis earthquake, it was considered as an example the plant arrangement shown in Fig.2 constituted by the nuclear outer containment (RB), which includes of the inner containment system (CS) and the reactor pressure vessel (RPV) structures with all its internal components, and the annex building.

The reactor building incorporates and surrounds the main safety relevant nuclear SSCs as well as the most important mechanical equipment devices.

The RB is characterized by a freestanding concrete building, having cylindrical shape and hemispherical roof, surrounding the containment system and is assumed to be based on a rigid foundation. In the following there are indicated some important dimensions assumed to perform seismic analyses of the considered plant:

- External diameter $D_e = 45$ m
- Building Height $H \approx 50$ m
- AB wall thickness ≈ 1 m
- Foundation thickness ≈ 2 m

The IRIS containment is completely within the reinforced concrete outer containment building, since the containment is only 25m in diameter.

3. BDBE ANALYSIS

It is estimated that, worldwide, 20% of nuclear reactors are operating in areas of significant seismic activity (Fig.2). In these areas nuclear facilities are designed to withstand that larger and severe earthquakes having very low probability of occurrence as well as other external events representing the design basis events (DBE) expected at each site, in order to avoid that those event may jeopardise the safety of the plant itself. The considered earthquakes are, generally, characterized by a ground motion (PGA) of magnitude 6.5 which occurrence was assumed directly under the reactor.

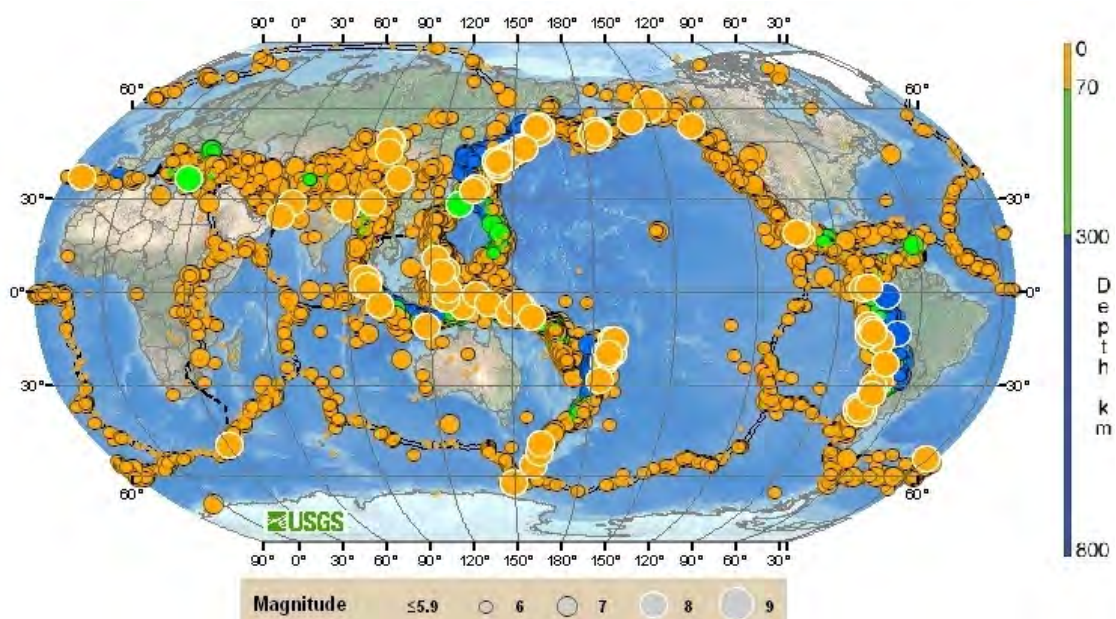

Figure 3 – Seismicity map

Seismic design of nuclear power plants is based on criteria more stringent than those applying to the most non-nuclear facilities, accordingly particular attention is paid to seismic issues in the siting, design and construction of NPPs: as a consequence of that nuclear plants are built preferably on hard rock foundations (not sediments) to minimise seismic shaking. The safety approach requires mainly to:

- Establish the safety objectives, criteria and requirements
- Implement them in the design
- Demonstrate the design satisfies the requirements

Dynamic response of the safety-related SSCs in nuclear facilities, when subjected to the ground motion resulting from a DBE or exceeding it, are then evaluated to ensure that the safety relevant SSCs will not be seriously damaged in a manner that would cause uncontrolled release of radioactivity to the environment and population. Therefore to ensure the safety functions of plant, the required safety objectives to match are:

- shutdown the reactor and maintain a safe shutdown;
- remove the decay heat;
- maintain the containment boundaries and function;
- control and monitor the plant;
- maintain the functional and structural integrity of SSCs.

It is important also to recognize that some nuclear facilities were designed and built many years ago and were not originally built to withstand a DBE or a BDBE resulting from the application of current seismic design and evaluation requirements as a result of the recent earthquake and tsunami in Japan. Therefore it is necessary to re-evaluate the SSC response in beyond design conditions to demonstrate that it is yet acceptable, according to the new/adjourned national and International nuclear requirements.

The “stress tests” (i.e. including the analyses of the effects of airplane crashes and terrorist attacks), as already mentioned, are focused on the risk and safety assessments of the existing/new or under development and on the evaluation of the safety margins of the nuclear power plants when facing a set of challenging situations.

International Regulatory Body (i.e. WENRA, IAEA, etc.) stressed the need to reevaluate the behaviour of a nuclear power plant subjected to Fukushima events conditions.

In the present study the recommended deterministic safety margin assessment (SMA) methodology, instead of the probabilistic safety assessment (PSA) one, was employed in a rather refined numerical methodology to simulate the induced BDBE effects.

The methodological approach adopted to evaluate the consequences of a severe earthquake on NPP structures must be based, according to WENRA suggestions, on the definition of the level of the design basis earthquake (DBE) expressed in terms of peak ground acceleration (PGA), which will be based on available information, because to define the earthquake severity, above which the loss of fundamental safety functions or severe damage to the fuel (in vessel or in fuel storage might occur), a probabilistic assessment becomes unavoidable.

The scope of a preliminary safety evaluation of the effects induced by a BDBE was achieved setting up and implementing a refined FEM model of the considered SMR reactor.

The FEM model of IRIS reactor building (Fig. 4) is assembled by means of suitable elements, as for example three-dimensional (3-D) solid and/or shell iso-parametric type elements, to adequately represent the behaviour of each mentioned structure.

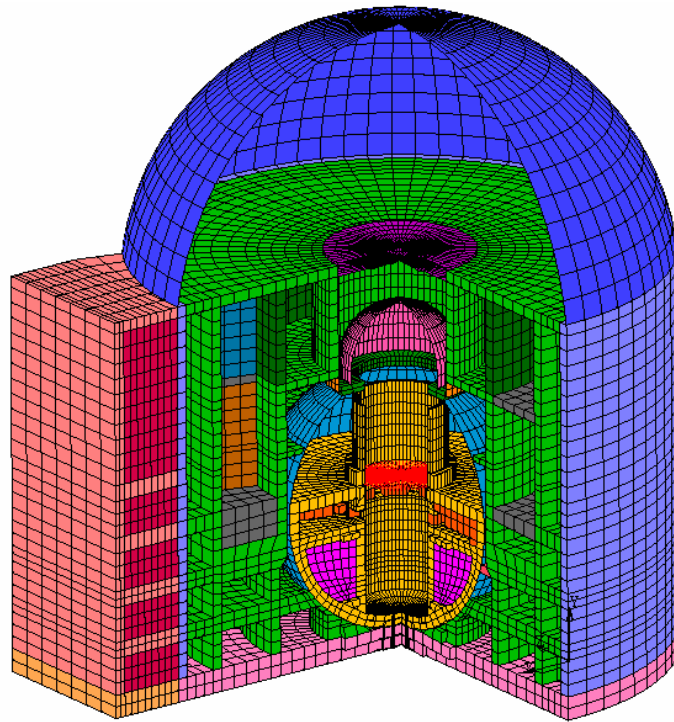

Figure 4 - RB FEM model

3.2 NUMERICAL INVESTIGATION

After having adequately modelled the RB main structures, BDBE non-linear analyses were performed applying the acceleration time history approach.

The input motion was applied in form of acceleration time history (all the three acceleration components in the three mutually orthogonal directions) was derived according to the Regulatory Guide US NRC 1.60 and compatible with the given free-field spectra. The maximum peak ground acceleration (PGA) was assumed equal to 0.6 g (Fig. 5) and applied at the nuclear basement.

The three acceleration components (shown in Fig.6) were calculated for a 5% damping, for a hypothetical embedment in stiff rock and for an excitation duration equal to 24 seconds.

Moreover the vertical acceleration was assumed equal to 2/3 of the horizontal one in the entire frequency range.

In the performed analyses on RB structure, the effect of simultaneous horizontal and vertical shaking was studied in order to adequately evaluate the capability of the structure to withstand the seismic loading in the worst case. On the other hand the attention should be focused on the propagation of the vertical acceleration component that, due to the rigid behaviour of the considered isolated structure, is entirely transmitted to the superstructure (this component is not really damped because of the high vertical stiffness of the isolators).

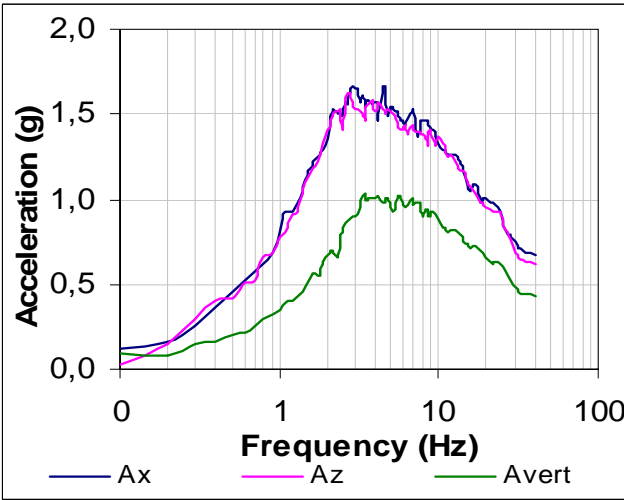

Figures 5 - BDBE response spectra

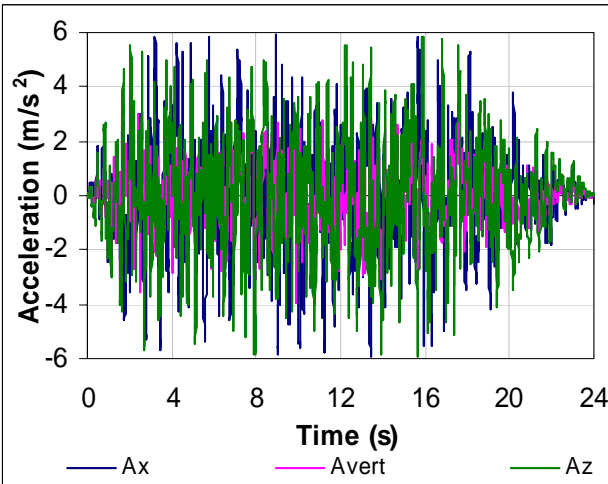

Figures 6 - BDBE acceleration time histories

3.3 BDBE ANALYSIS RESULTS

To assess the safety margins of the considered SMR reactor in the light of the events which occurred at Fukushima, non linear dynamic transient analyses of the RB structure were performed.

The obtained accelerations (Fig.7) and relative displacements (Fig.8), at various reference points and elevation inside the RB, as for instance at the RPV skirt restraints or at the containment building roof, were analyzed, highlighting an amplification of the accelerations along the height of RB itself, especially at the highest floors, where it can be 2 times higher than the earthquake PGA due to the overall containment building flexibility.

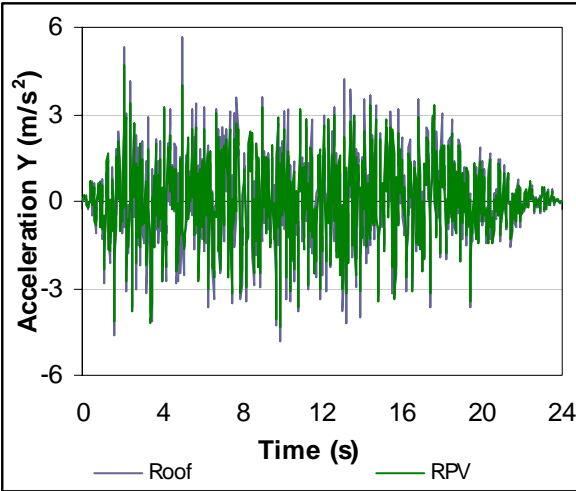
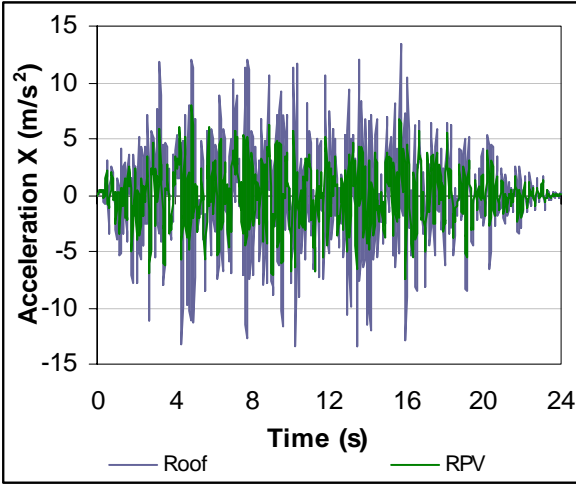

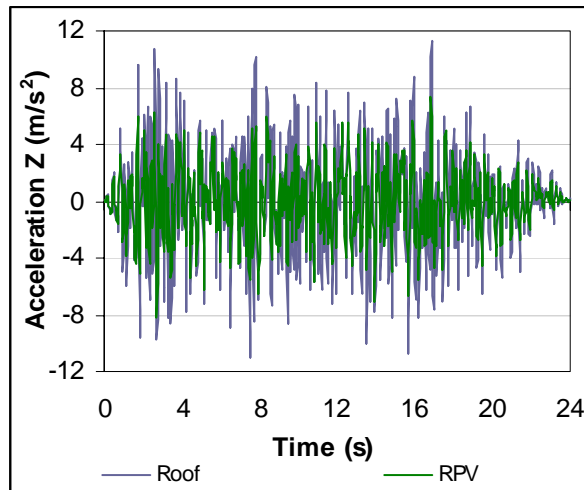
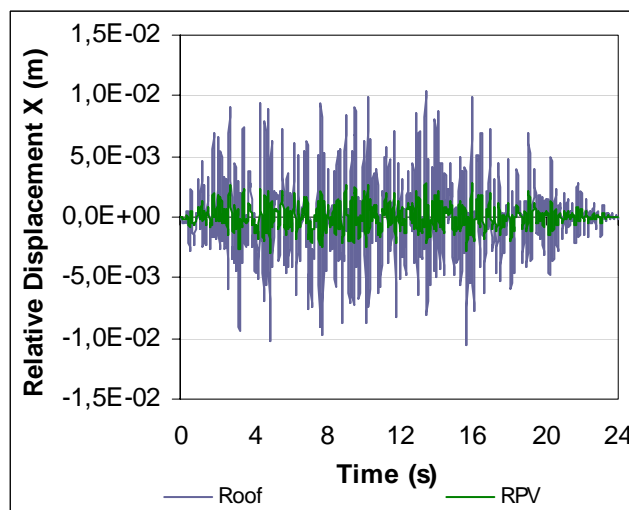

Figure 7 - Accelerations behaviour at different RB elevations

As for the relative displacement concerned (with reference to the ground), it was highlighted that the horizontal values, particularly, increased along the RB elevation reaching 10 cm at the containment building roof and about 3mm at the RV restraints; these displacements could determine any problem to the connections between the RB and the adjacent auxiliary and turbine building.



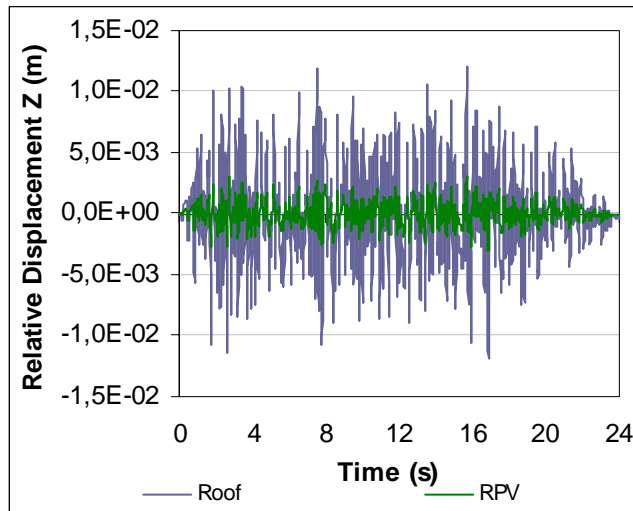
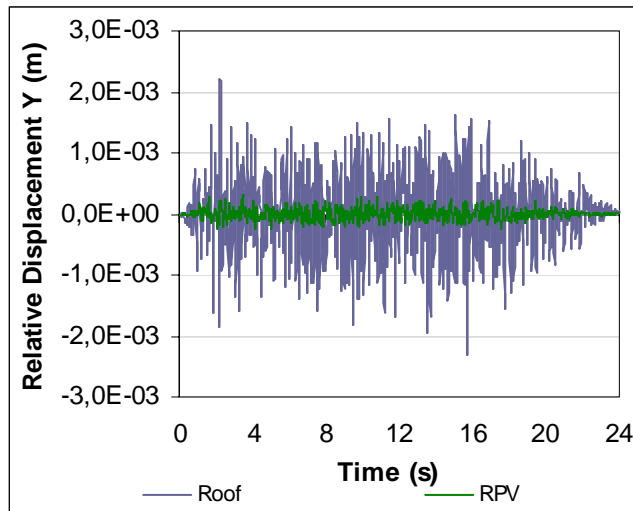

Figure 8 - Displacements behaviour at different RB elevations

Finally the floor response spectra were calculated into the frequency domain in correspondence of the reactor vessel that is the most important structure from a safety point of view.

The behaviours summarized in Fig. 9 highlighted an increase of the accelerations from the ground up to the considered structure (like the RV supports) of about 30%, for both the horizontal and the vertical components.

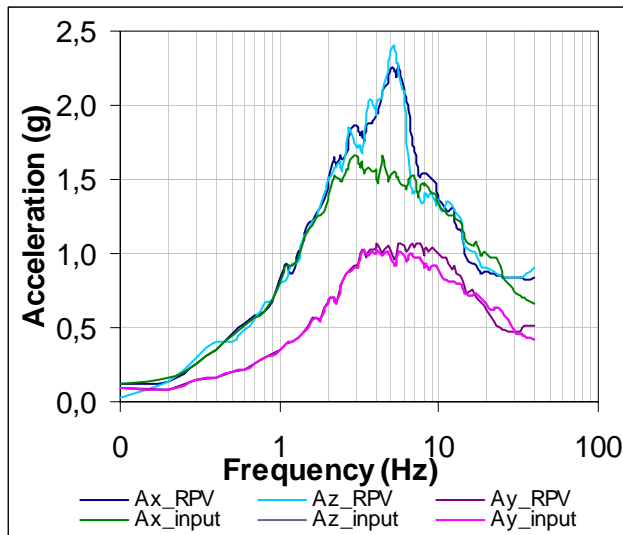

Figure 9 - Response spectra comparison

In figure 10 it is represented the Von Mises stress distribution inside the RB structure. The stress distribution in reinforced concrete building showed that the RB structure has stress values closer to its ultimate strength, beyond which structural damage relative may come out with possible loss of RB structural integrity.

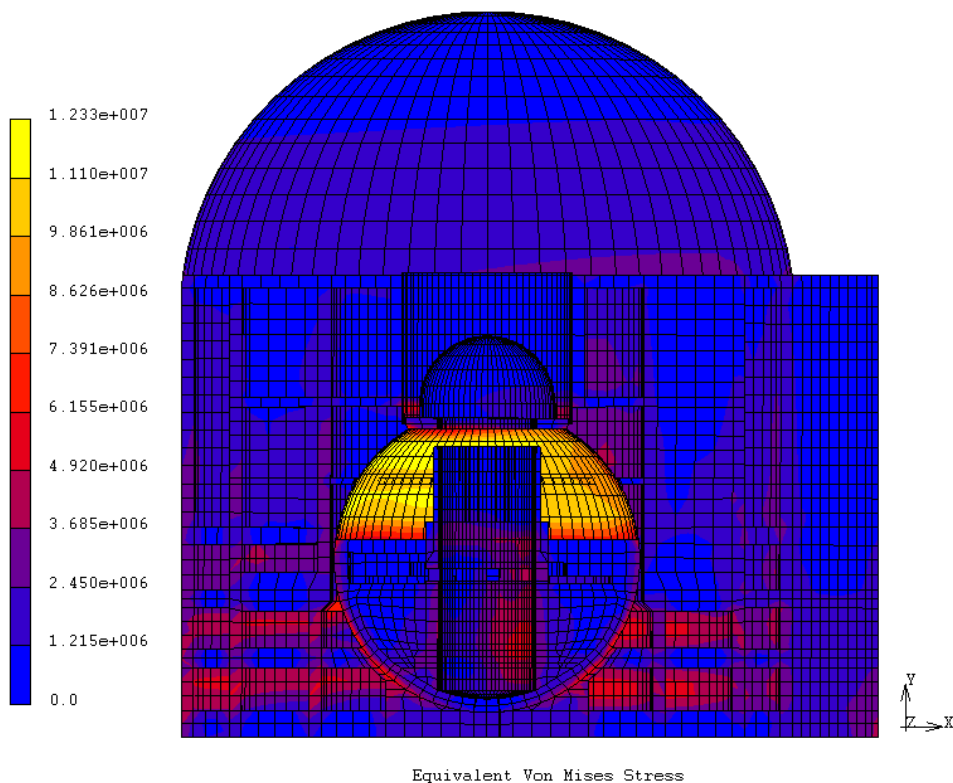

Figure 10 – Stress behavior inside RB

Subsequently, the obtained acceleration values were, in turn, used to evaluate the structural integrity of the main primary system safety relevant components, in the assumed extreme situation, and to eventually support further structural design optimisation in order to avoid sequential loss of the lines of defence leading to potential severe accident situations. As for the concerned RPV structure, the propagation of accelerations through the CB structure did not correspond to relevant stress values as it is clearly highlighted in Fig. 11, but also that the structure is suitable to be easily upgraded with relatively simple measures, e.g. related to increasing the structure thickness or adopting the isolation technique to the containment building foundations.

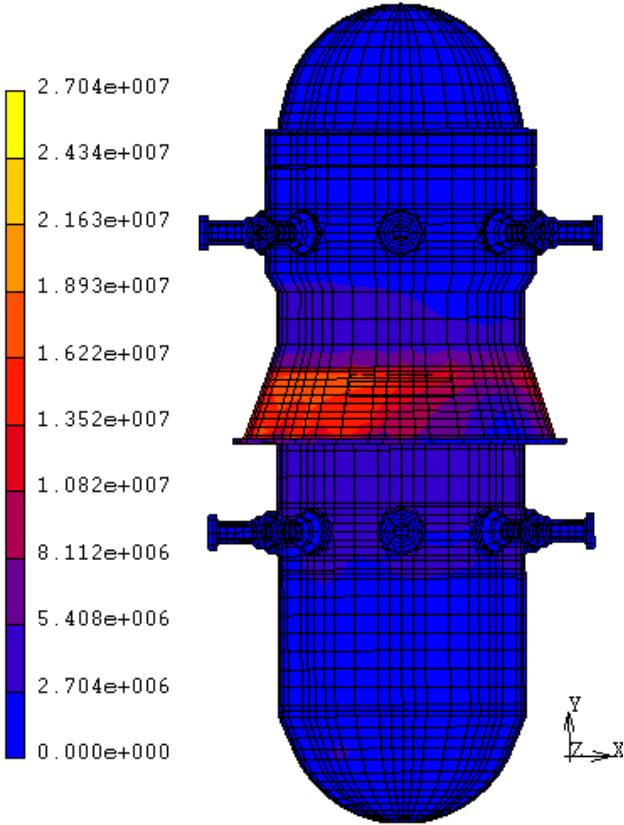

Figure 11 - Von Mises stress distribution inside the RPV

Moreover in conclusion, the applied methodology approach appeared to be able to analyze the safety margin of the considered NPP matching the intent of the proposed stress tests.

4. AIRCRAFT IMPACT ASSESSMENT

The problem of the reliability of a NPP, in the case of a severe external event like the aircraft impact, is mainly related to the evaluation of the minimum wall thickness of the reactor building (RB) necessary to ensure the overall plant safety and, in the same time, to prevent the local perforation, particularly when a large jet airliner crash is considered.

The evaluation of the RB wall thickness unavoidably entails with the assessment of the possible effects of the impact of a military/large commercial aircrafts (Riera 1968; Crutzen and Reyneu, 1983; Abbas et al., 1996, etc.[5-6-7]), which is considered a beyond design basis accident, on the nuclear plant, and must be consistent as within the rules for new plant designs (10 CFR 50.150). Moreover a realistic aircraft impact analysis is at present required by the international regulatory bodies, like the IAEA or the U.S. NRC [8], to demonstrate the integrity of the containment building (referred to the adopted “acceptance criteria”). Therefore to attain the intent of this study, a safety margin analysis, based on a deterministic approach, was performed to demonstrate that the reactor containment could safely withstand the impact of a large commercial aircraft without loss of its integrity.

The potential consequences of an aircraft impact loading on the RB structures of the plant and analyze the behaviour of the safety relevant internal structures (that deals with the global or local SSCs structural response), were preliminary evaluated taking into account an under development SMR, like IRIS NPP previously described. Therefore, the attention has been paid to the containment building characterized by a double barrier consisting of an inner and an outer containment structure.

The plant response will depend to a large extent on the transferred dynamic loads on the outer containment and on the RB design. Therefore in order to simulate properly and realistically the aircraft crashing, it is important to determine the impact load, propagated to the RB walls.

Two distinct types of structural failure modes need to be evaluated for RB structures:

- The global failure (plastic collapse) caused by impact of the complete aircraft;
- The local failure (scabbing and perforation) caused by impact of the aircraft engines.

The local failure is independent of the characteristics of the impacted structure, whereas the global one depends mainly on the dynamic characteristics of the target structure.

The impact load, that is transferred during the striking of the aircraft is due to the kinetic energy, which is partially absorbed by the building in the form of local strain energy (dissipated by plastic deformation and fracture) and in part by the aircraft structure (crushing and breaking of the plane). It is important also to note that a small contribution of the kinetic energy, that may be considered negligible, is dissipated by friction and converted in vibration.

The Nuclear Regulatory Commission (US NRC) has determined that the impact of a large, commercial aircraft must be considered a beyond-design-basis event.

The final aircraft impact assessment rules revised in 10 CFR Part 50, “Domestic Licensing of Production and Utilization Facilities” and Part 52, “Licenses, Certifications, and Approvals for Nuclear Power Plants,” introducing among the requirements for new reactor designs a specific evaluation of the effects of the impact of a large, commercial aircraft using realistic analyses. Therefore, as already mentioned, a deterministic approach has been adopted.

The sequence of localized loading effects consists of three stages-missile penetration into the target, spalling and scabbing of the target and, potentially, missile complete or partial perforation completely through the target walls; these effects may be defined as follows:

1. the penetration corresponds to the displacement of the missile into the target, equivalent to the depth of the shallow depression area at the zone of impact;
2. the spalling is the ejection of target material from the front face of the target;
3. the scabbing corresponds to the ejection of material from the back face of the target (i.e., opposite the face of impact).
4. the perforation occurs when the missile fully penetrates and passes through the target.

As for the global response concerned it can be characterized by major structural damages, such as the collapse of large portions of the building walls, floors, and load carrying members. The airplane impact will also potentially induce vibrations throughout the building, that are not considered in this evaluation. Moreover the full-scale engine impact tests on concrete walls [9] have demonstrated that the potential damages of a turbojet airplane can be predicted using modified empirical formulas developed by Riera (Fig. 12). Therefore in the performed analyses it has been assumed the hypothesis of constant aircraft velocity during impact; subsequently the load time functions, $F(t)$, were determined according to the Riera method (Fig. 12) (validated by means of experimental tests and computation analyses[9-10]). These load functions, used in the

presently performed simulations, have been calculated applying similitude correlations mainly based on the airplanes weight and velocity.

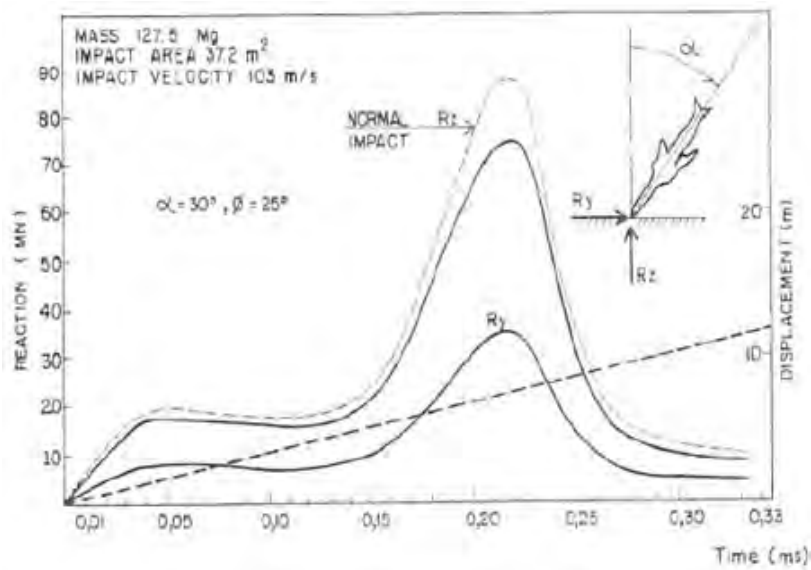
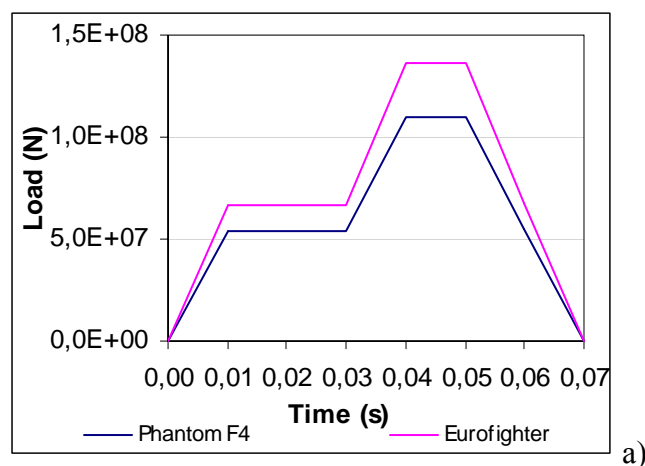

Figure 12 – Riera load time function, $F(t)$

Therefore according to the Riera mentioned modelling the scaling of the time and the impact force was done to determine the load functions for airplanes other than the Phantom F4 or the Boeing 707-320: the adoption of the mentioned similitude correlations leads to a conservative approach because of the assumptions related to the case of an aircraft impact against a rigid wall.

The obtained load functions assumed for different military and commercial aircrafts are shown in Fig. 13, where the first peak represents the crushing of the fuselage whilst the second one, that is much more severe, is associated to the following engines impacts.



a)

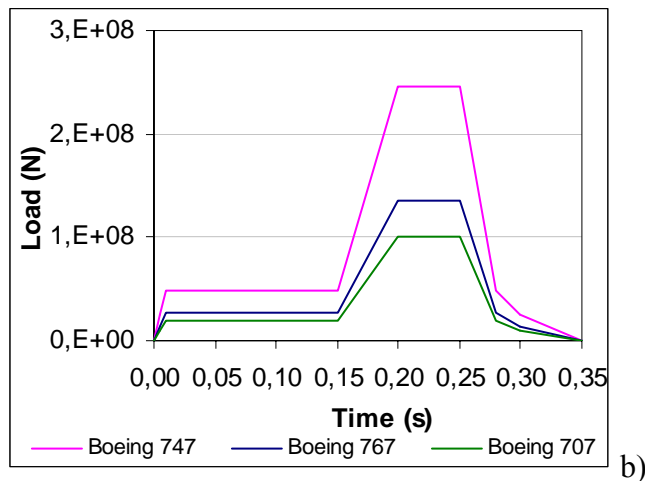

Figure 13 - Load-time function for different military (a) and civilian (b) airplanes

4.1 GLOBAL RB DYNAMIC RESPONSE

The evaluation of the global dynamic behaviour of the RB structure is of strategic significance because the damages caused to the outer containment structure may jeopardize the plant safety. To determine the dynamic response of RB structure and to evaluate if its outer walls are sufficient and robust enough to bear the considered aircraft impact event, as already mentioned, a deterministic method has been applied. To this purpose non linear analyses have been performed implementing suitable feature capable to simulate the structural damage phenomena as well setting up a refined model of the considered RB structure (adopting MSC[®] codes) with reasonable hypotheses for the structural materials characteristics (e.g. concrete and steel) and geometrical dimensions, assuming also the building fixed at the foundation level.

The numerical model for the concrete structure was set up with SOLID-3D elements and steel members (reinforcement and pre-stressed steel) are embedded as discrete bars by using TRUSS-3D elements (6 degree of freedom element, i.e., three translation and rotational components): their non-linear behaviour was dealt with appropriate elastic-perfectly plastic option.

The strength of concrete under multiaxial stresses is implemented as a function of the state of stress, which cannot be predicted assuming the simple tensile, compressive and shearing stresses independently of each other. Therefore, the behaviour of the concrete can be properly determined only by considering the interaction of the various components of the stresses.

In the implemented model, the reinforced concrete structure was assumed to undergo gradual failure modes in tension, based on the maximum stress failure criterion.

The longitudinal layers of reinforcing bars within the concrete RB walls were represented by smeared uniformly distributed layers of steel having non-linear behaviour (having yield stress 375 MPa). The thickness of these layers was determined by assuming that the cross-sectional areas of the reinforcing bars are spread uniformly along the respective layers. Furthermore in the present study it has been assumed an attack from multiple entry directions for both a military aircraft and a large commercial airplane.

In particular, the A and B entry directions, represented in Fig. 14, have been considered to evaluate the vulnerability of the considered RB structure by means of the mentioned models.

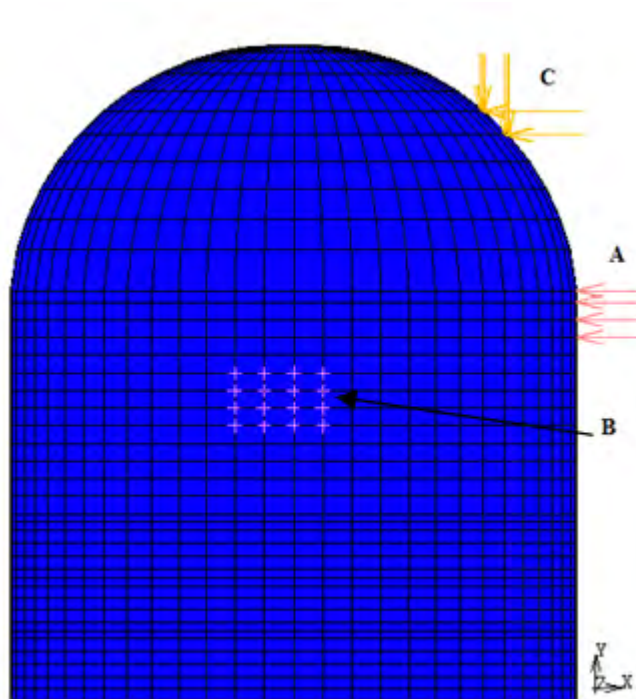
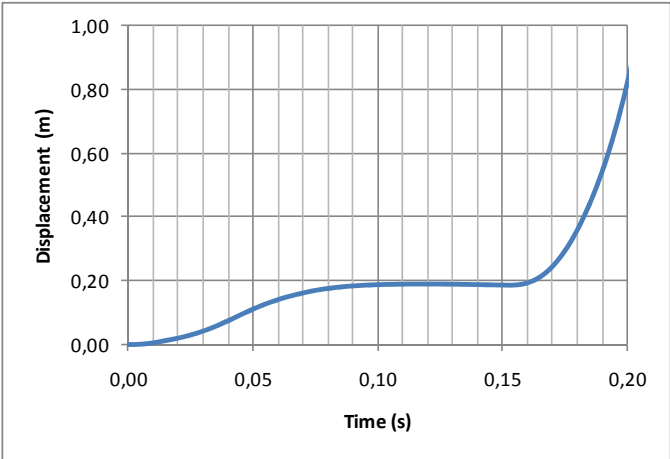

Figure 14 - Entry directions in the aircraft impact analyses

4.2 MAIN AIRCRAFT CRASH ANALYSES RESULTS

In the performed impact analyses it was observed that the RB structure dissipated the impact loads through the plastic deformation of the RB walls and the penetration (and eventually spalling) of the reinforced concrete walls.

Overviews of the obtained results in terms of total penetration depth vs. time in the RB structure (in correspondence of the considered impact entry points and far away from this location) for the impact of the Boeing 767 and the Phantom F4 examples, are shown in the Figs. 15.



(a)

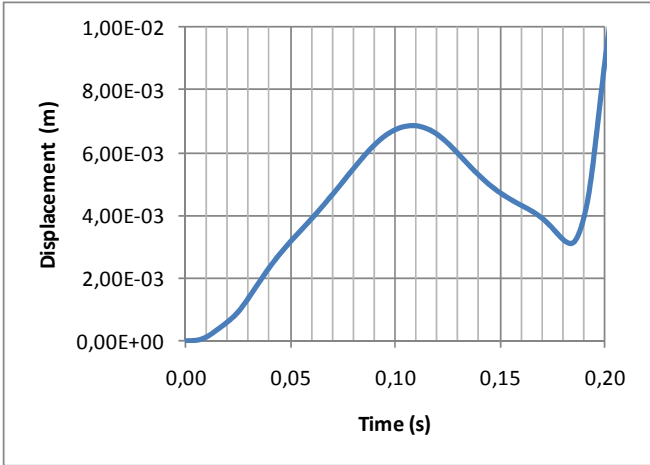

(b)

Figure 15 - Penetration depth vs. time for the Boeing 767 close (a) and far away (b) the impact entry A

It is worthy to note that the global response of RB structure, as it was foreseen, is characterized by a localized penetration close to the impact area, whose depth was observed to be dependent on the type of aircraft considered and also on the entry direction.

Moreover analysing the obtained results it has been observed that the impact of the Eurofighter is more severe than that of the Phantom F4 for the same entry direction A.

In addition it is important to highlight that although the Eurofighter impact seemed much more severe than the Phantom F4 one (shown respectively in Fig. 16 (a) and (b)), it did not determine an extensive penetration of the outer RB walls like the impact of the other considered civilian aircraft type, like the Boeing 747 or 767 for the same entry direction A (Fig. 16 (c) and (d)).

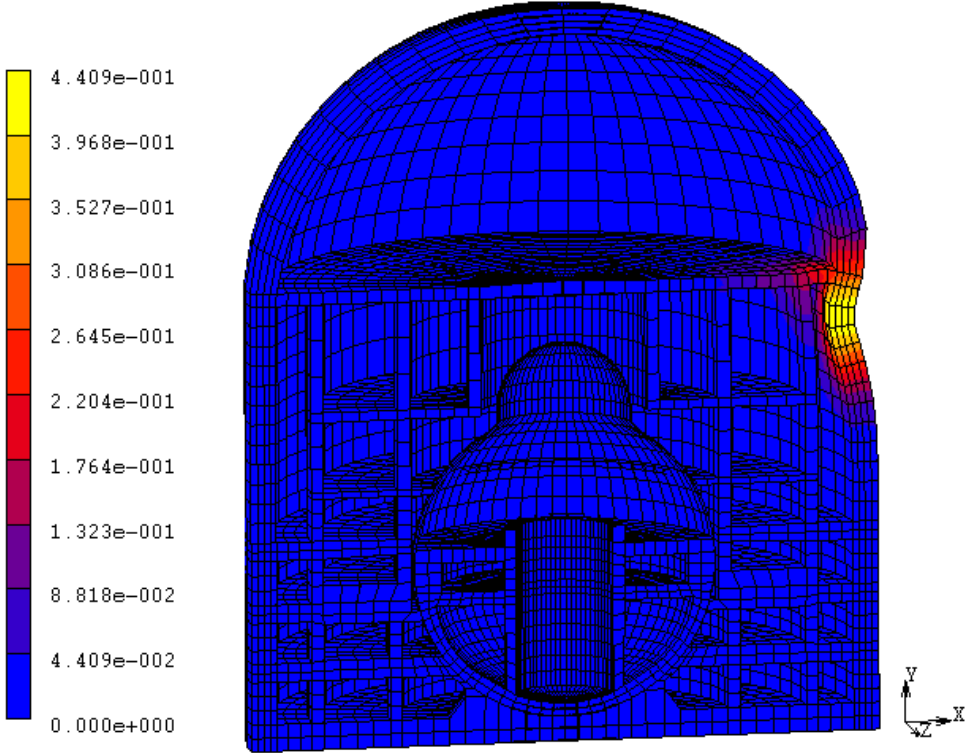

(a)

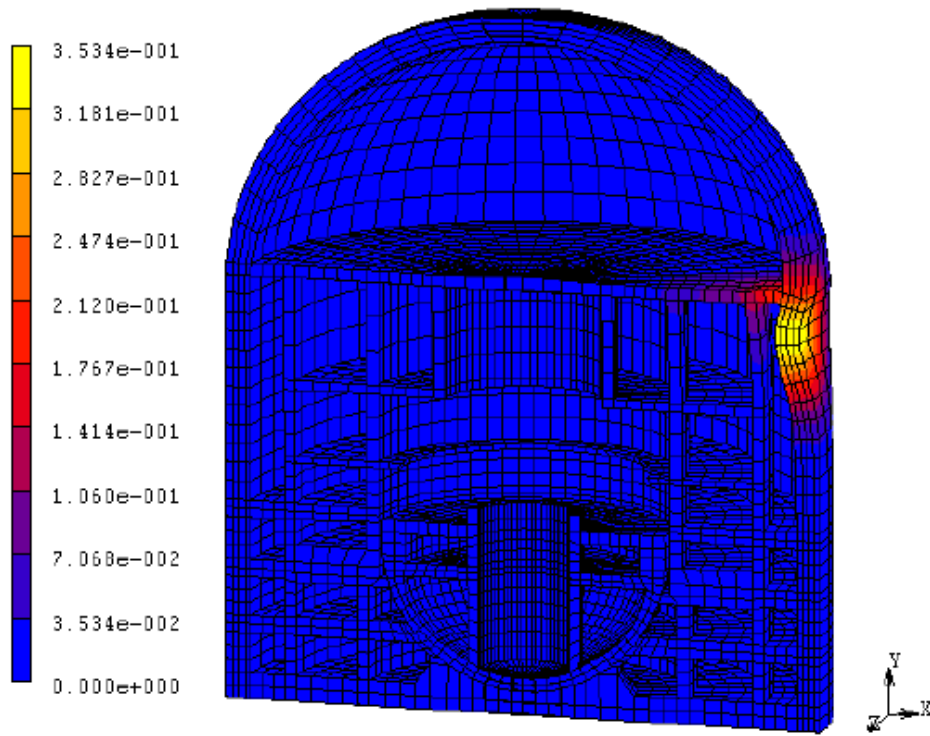

(b)

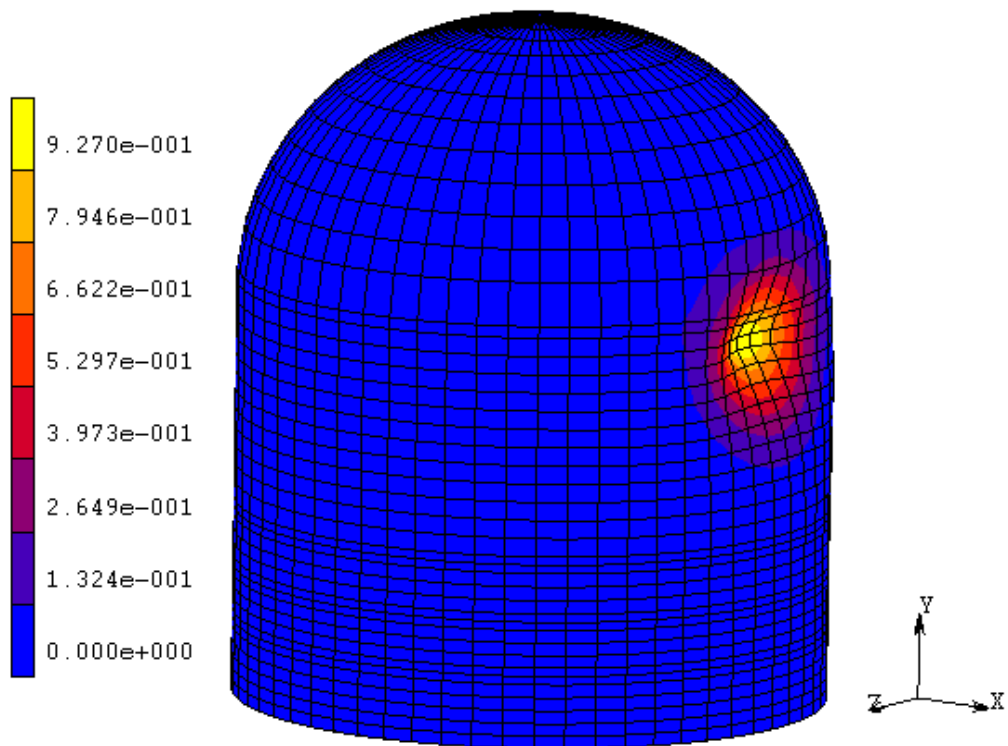

(c)

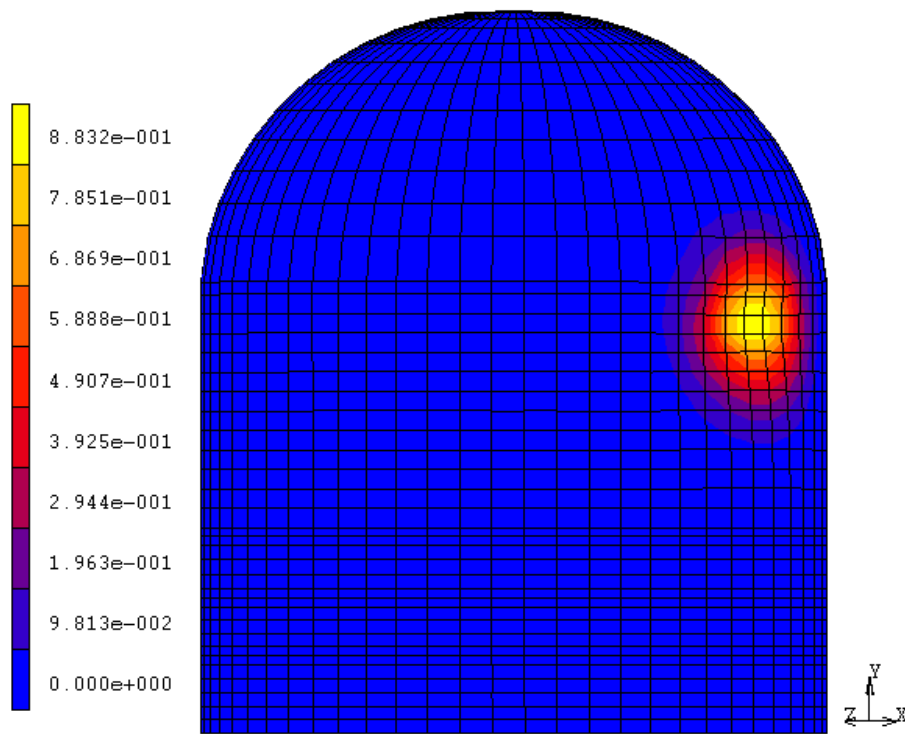

(d)

Figure 16 - Penetration depth at the engine impact for Eurofighter (a), Phantom (b), Boeing 747 (c) and 767 (d)

The impact of the engine resulted in a progressive failure of the reinforced concrete walls coupled to a rather wide and narrow penetration depth (ranging from 40 to about 85 cm in the area where the impact was localized, like it is shown in the previous Figs. 16) and in an increase of the stress level in the reinforcing rebars up to the yielding value, due to the energy transmitted during the crushing.

It was also highlighted that the inclined impact (entry direction C) was less damaging than the horizontal one for all civilian aircraft type, confirming the Riera approach. In fact in this case the penetration depth resulted, for Eurofighter about 0.2 m.

In Fig. 17 it is represented the rebar stress behaviour in the case of the impact of the Boeing 747, as an example. The Von Mises stress behaviour highlighted that the reinforcing steel rebars provided the adequate stiffness and load bearing capability to absorb the impact energy and prevent the RB wall perforation.

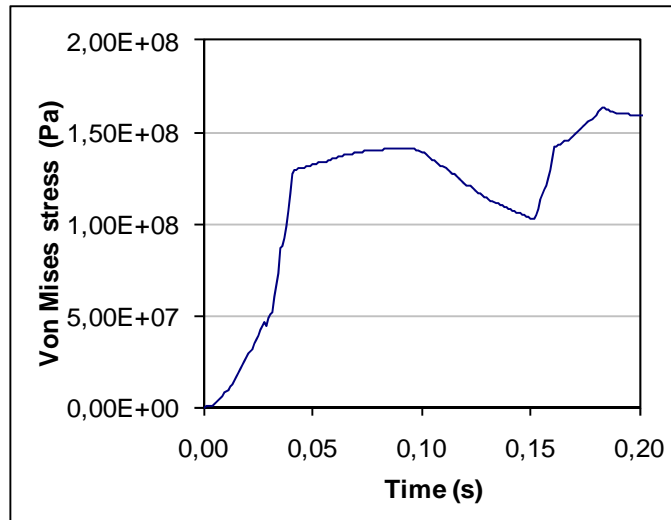

Figure 17 - Rebar stress behavior close to the impact entry A for the Boeing 747

As far as the Boeing 747 impact is concerned, it resulted, of course, to be more damaging than that of the other considered military airplane crash, as clearly indicated in the distribution or mapping of the damage induced particularly at the impact of the engine highlighted that the whole RB structure suffered material deterioration processes. In the performed analyses it has been also calculated the time histories of the accelerations at each relevant point in the RB inner structures (the vibration problem arisen from the propagation of these accelerations is not part of this study). Analysing the obtained acceleration values it seemed that the RB wall absorbs the impact energy by local deformation that in turn results in a reduction of the transmitted accelerations. Fig. 18 show exemplarily the horizontal acceleration values (in figures the indicated acceleration unit is m/s^2) propagated at the containment vessel for different airplanes impact.

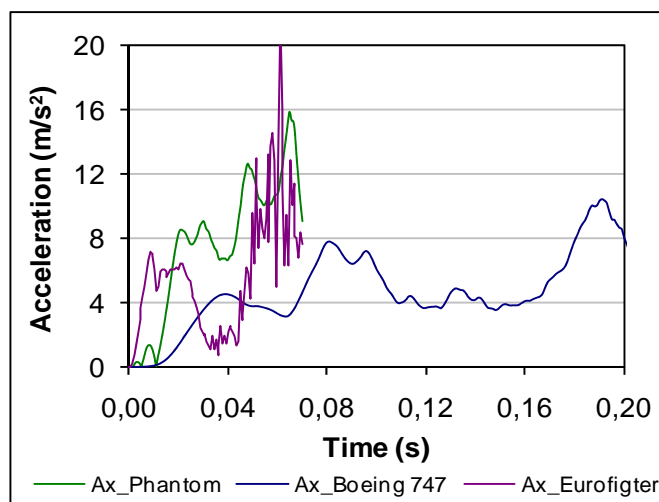

Figure 18 - Horizontal acceleration comparison for different airplanes impact

The horizontal acceleration values highlighted, as it was possible to foresee, that they are greatly influenced by the type of impact occurred (a military jet impact has a short crashing duration of about 0.07 s) and by the distance from the aircraft impact location. Furthermore it was observed that the impact at the entry directions A and B (corresponding to horizontal impacts) were more significant from a structural point of view because the impact area are closer to the inner vessel containment: the mean value of the accelerations propagated up to this structure were about 6 g for both Phantom and Eurofighter airplanes.

Generally it is possible to state that the assumed RB design configuration resulted capable to assure the integrity of the containment structure, despite some penetration and spalling of the concrete (chipping of material at the impact point).

5. TSUNAMI ASSESSMENT

“Tsunami” is a Japanese word that literally means “harbor (‘tsu’) wave (‘nami’)” and typically refers water waves that propagate, from the point of generation, through the ocean (for long distance) in the form of gravity waves with little loss of energy toward the shore.

The extent of flooding and tsunami and the induced height of the water waves, most often caused by big earthquakes, need to be considered for the design of a NPP site because the induced hydrostatic and hydrodynamic forces (as well as the impact of debris and projectiles) associated with the arisen waves can damage safety relevant structures resulting in a severe hazard to the nuclear plant.

A map of the tsunami registered (about 2180 events from 1628BC to 2005) in the world is represented in figure 21, while figure 22 shows the catastrophic event (in terms of death) in the time (courtesy of Australian Spaceguard Survey).

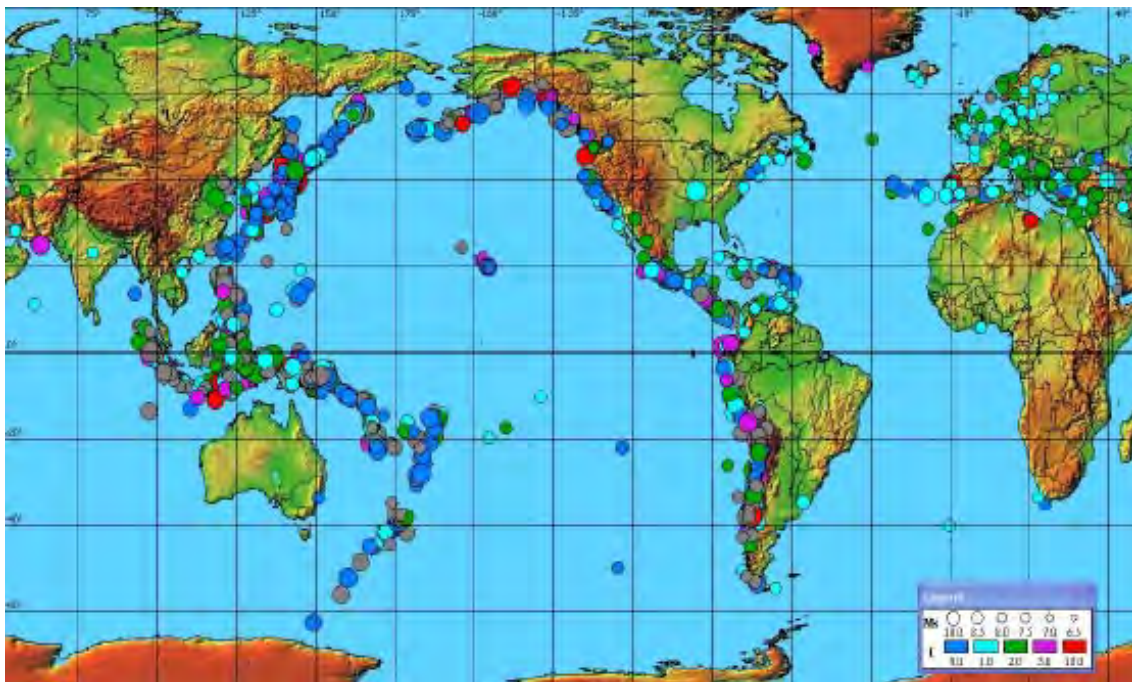

Figure 19 - Recorded tsunami event

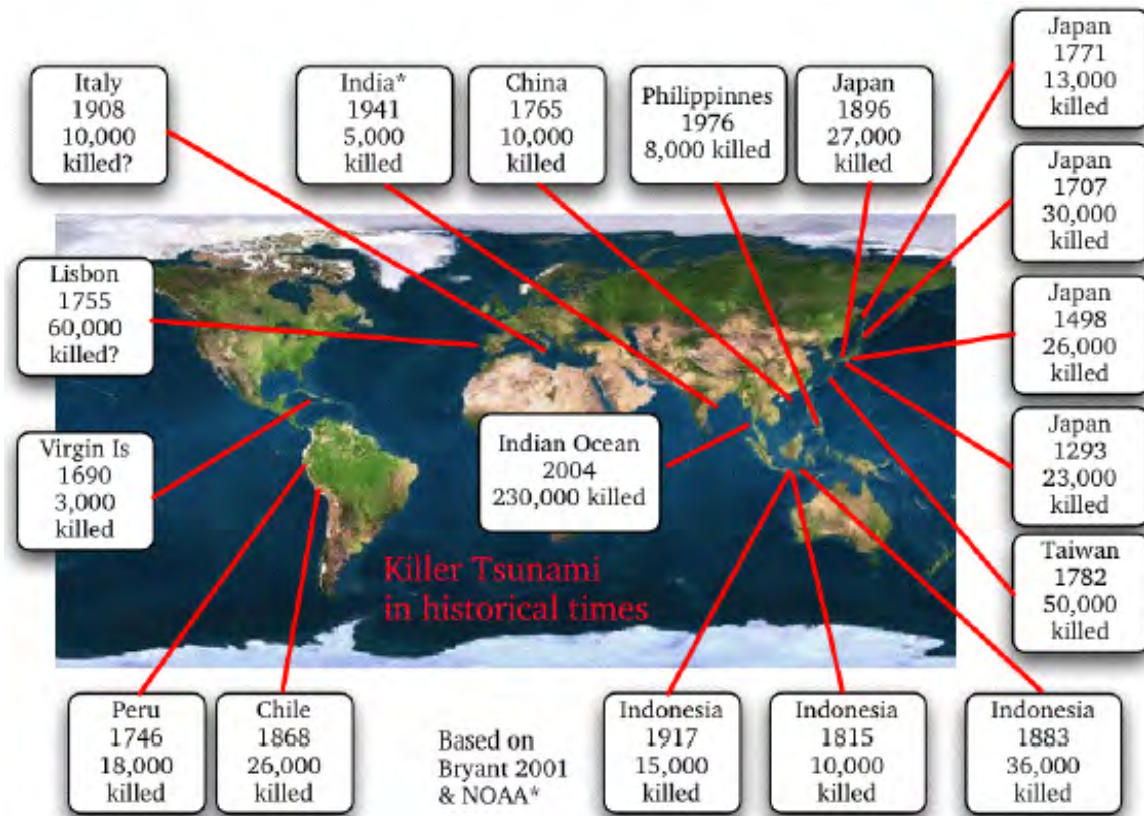

Figure 20 – “killer” tsunami event

The tsunami wave generated by the recent Fukushima Magnitude 9.4 earthquake on March, 2011 attracted the worldwide public opinion showing the catastrophic damages (Figs. 19) occurred at the Daichi and Daini nuclear plant sites and also to the civil building and structures (as well as the death) induced by the growth and impact of the more than 14 m high water level. This event jeopardizes simultaneously both the control and cooling functions of the Fukushima plant (Figs. 20): “beyond-design-basis accident” situation.





Figure 21 - Tsunami waves impinging on the 6 m protective wall of the nuclear plant



Figure 22 - Water waves ingress at the base of the ventilation stack system

The primary effects of the tsunami waves on a near shore nuclear plant site are due to the flooding, which may induce possible loss of cooling water (due to dry intakes during drawdown caused by receding tsunami waves). Subsequently there are several other possible secondary effects, mainly due to the hydrodynamic and impact forces that can cause severe damage to structures and the foundations of these structures or serious damages to the emergency accident by the RHR systems (in complete station black out conditions).

5.1 BASIC APPROACH TO TSUNAMI ANALYSIS

Tsunami generally consists of a series of waves with periods ranging from minutes to hours (arriving in a so-called "wave train") and wave heights that could reach tens of metres.

Tsunamis are generated by various causes: earthquakes originating from submarine faults, underwater volcanic activities, submarine landslides and sub-aerial landslides impinging on the sea [11].

In the case of submarine earthquake-induced tsunami, the wave is generated with the displacement of the seabed. This propagates as a long wave train depending upon the sea bathymetry and diffraction and reflections from surrounding geographical features. Upon their arrival at the shore, the waves go through a run-up and dissipate their energy.

The inland propagation of water waves is characterized also by floating objects, such as boats and cars, that can cause impacts able to induce damages to various infrastructures and obstruction effects even at several kilometres from the coast.

To evaluate the wave height at a site, induced by a tsunami, due to an earthquake, several information are necessary, such as the determination of the movement of the seabed, the initial movement of water in the region of the earthquake epicentre, the propagation of the tsunami wave in the ocean and the modification of the wave height during inland run-up phase (mainly as a consequence of the local variations in bathymetry and shore profile).

First of all it is important to stress that the tsunami is a hydraulic phenomenon of marine submersion characterized inland by a non-Newtonian flow with a heavy sediment charge [12] characterized by three phases:

- 1) The initiation;
- 2) The propagation;
- 3) The inundation.

Little energy is lost during the propagation of the water waves, and the speed at which these waves travel can be estimated on the theory of shallow-water waves basis.

The propagation phase can be approximated well with linear theory.

In the final phase the waves enter shallower waters near the shore, shorten in wavelength, and increase in amplitude and height: nonlinear effects, such as the amplification, reflection, refraction of the wave and other interactions that may further modify the characteristics of the tsunami waves become significant and cannot be neglected.

As for the tsunami effects (damage mechanisms) concerned, they are determined by the impact of first approaching wave and second waves (separately or simultaneously) in relation to the magnitude of the phenomenon: the smashing force of a water wall travelling at high speed and

the destructive power of a large volume of water draining off the land and carrying all type of mobile objects with it, even if the wave did not look large.

It is generally recognized that it is the front impacts and the lateral pushing of the second wave to be more dangerous along the tsunami transit.

Seven main processes characterizing the tsunami impact have been determined (Fig. 23) and three different dynamics zones of a tsunami inland have been identified: each one of these processes can be described by one or several physical parameters (magnitude criteria) that can be theoretically measured and used for modelling the tsunami.

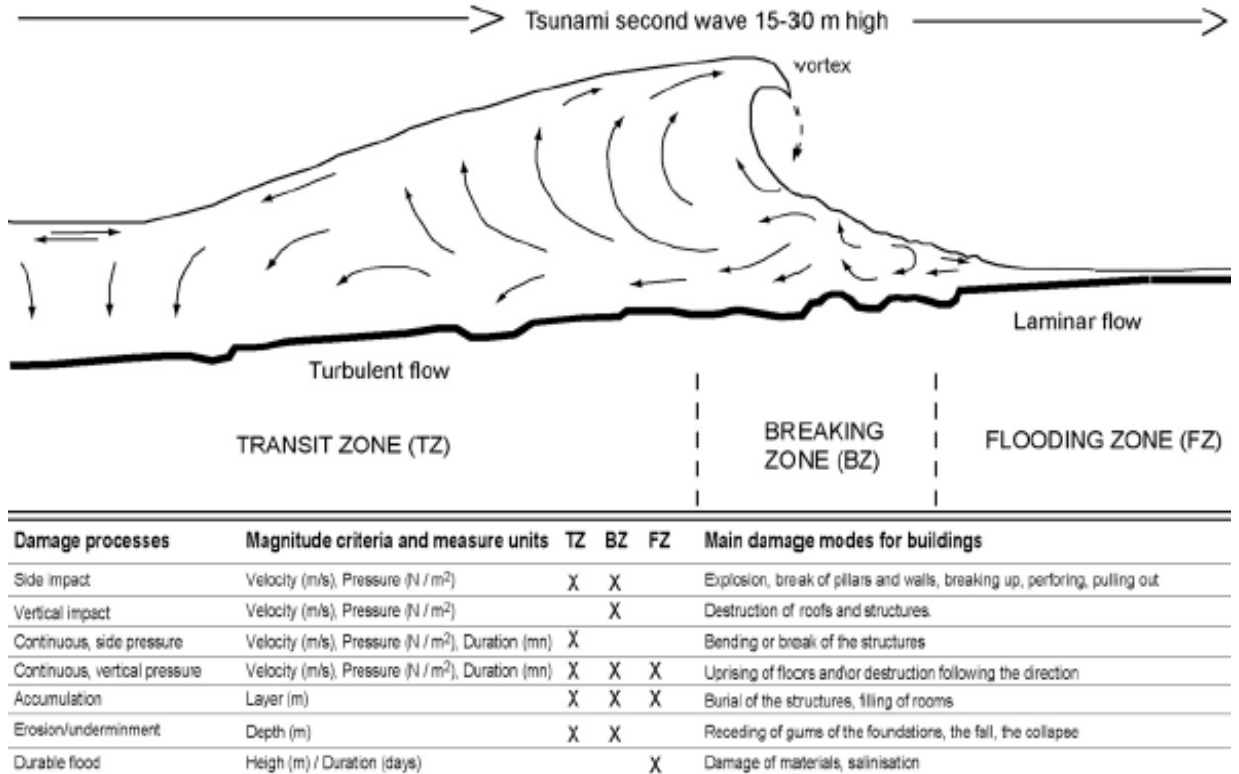

Figure 23 –Processes and main associated damage modes on buildings (second wave)[13]

According to Leone et al. [13] as for the energy of the second breaking wave (with reduced height), it is possible to distinguish these basic processes from upstream (transit zone) to downstream (flood zone), and at the core breaking of the wave (breaking zone, see previous Fig. 23).

Transit and breaking zones are characterized by turbulent flows with very high energy; while the flood zone is characterized by laminar flows. These hydrodynamic processes involve water pressure and impact forces (generated by the interaction with the seabed and coast), which are a function of the velocity, the flow depth and of the carried along debris.

The theoretical formulation and analytical solution for each phases of tsunami are based on simplifying assumptions, as described by various authors like Sharma et al., 2005, Cho et al., 2004.

In general Magnitude scales of Imamura (1949), Iida (1970), Soloviev (1970), Abe (1981), Hatori (1986) and Murty and Loomis (1980), were based on maximal wave heights (H_{max} in meter) on coast [14].

The highest wave measured on Uleelheue (14 m) corresponded to a level 3 on the Imamura and Iida scale ($M = \log_2 H_{max}$) and a 9.1 in Abe classification.

The flow depth of the studied phenomenon can also be used to characterize tsunami magnitude: in fact tsunami depth may be considered in theory proportional to the square root of its velocity. Moreover it is useful to remember that as the tsunami approached the coast, its wave length decreased as well the associated velocity while its amplitude increased in relation to the energy conservation equation, as represented in figures 24.

Indeed in deep water, the wave length is much less than water depth, while in shallow one the wave length is much greater than water depth (the profile of the water motion becomes elliptical that get flatter toward bottom).

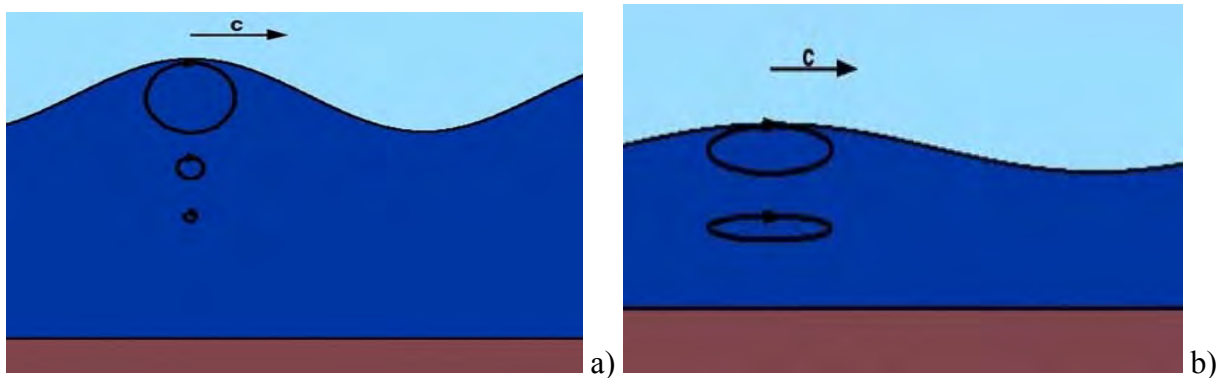

Figure 24 – Water wave for deep and shallow depth

The first scales used routinely to measure the intensity of tsunami were the Sieberg-Ambraseys scale, used in the Mediterranean Sea and the Imamura-Iida intensity scale, used in the Pacific Ocean. The latter scale was modified by Soloviev, who calculated the tsunami intensity I according to the formula:

$$I = \frac{1}{2} + \log_2 H_{av} \quad (1)$$

where H_{av} is the average wave height along the nearest coast.

The first scale used to calculate the magnitude of a tsunami was the ML scale proposed by Murty & Loomis based on the potential energy, but due to the difficulties in calculating the potential energy of the tsunami, Abe tsunami magnitude scale M_t , was used. This scale relates the magnitude to the maximum tsunami-wave amplitude (in m), h , measured by a tide gauge at a distance R from the epicenter, as follows:

$$M_t = a \log h + b \log R = D \quad (2)$$

where, a , b and D are constants used to make the M_t scale match as closely as possible with the moment magnitude scale: in figure 25 it is represented the relationship between the earthquake Magnitude, M , and the tsunami magnitude, m .

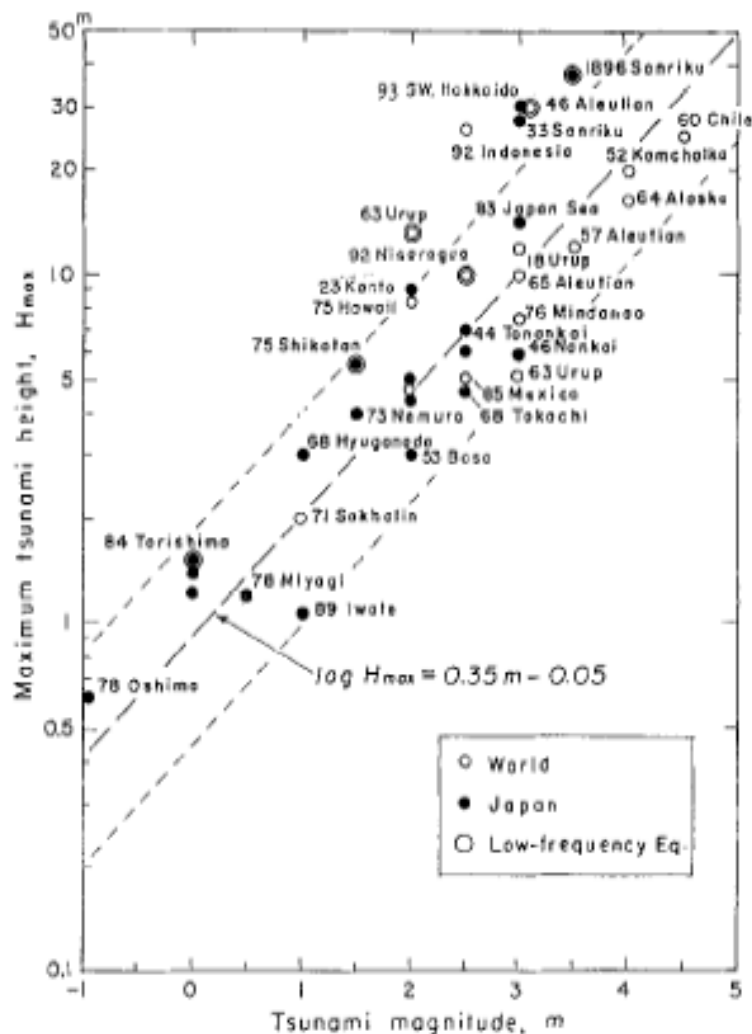

Figure 25 – Relation between tsunami magnitude and the maximum run-up height.

5.2 PROPOSED APPROACH TO TSUNAMI ANALYSIS

According to the ASCE/SEI 7-10 [15] the methodological approach for the design of buildings and other structures in area having high risk (category equal to V-Zones) is based on the evaluation of the design flood elevation (DFE) and of hydrostatic and hydrodynamic loads caused by the moving wave water.

The water waves elevation should be evaluated in relation to the flood average velocity, that in turn might be calculated noting the correlation between the PGA of the earthquake and the magnitude of tsunami.

After that, the breaking wave height (H_b) must be calculated as:

$$H_b = 0.78d_s \quad (3)$$

Where d_s indicates the local still water depth, that shall be calculated in agreement with the Eq. 5.4-3 of the mentioned ASCE/SEI rules. This values may be determined applying the following formula:

$$d_s = 0.65(BFE - G) \quad (3)$$

Where BFE is the assumed design flood elevation while G is the ground elevation.

Wave loads, that are those loadings resulting from water waves propagating over the water surface and striking a building or structures, may be calculated adopting analytical, numerical or laboratory test procedures.

Hydrostatic force acts laterally on structures. It can result from standing water resulting from tsunami inundation or from interaction of tsunami water moving slowly and encountering the Structures; hydrodynamic ones result, instead, from rapidly moving water and its interaction with structures (impact of the waves on the building walls).

The maximum pressure and the net force resulting from a normally incident breaking wave, in the hypothesis of limited depth in size, acting on a rigid vertical wall may be calculated as follows [15]:

$$P_{\max} = C_p \gamma_w d_s + 1.2 \gamma_w d_s \quad (4)$$

and

$$F_t = 1.1C_p\gamma_w d_s^2 + 2.4\gamma_w d_s^2 \quad (5)$$

where:

P_{\max} is the maximum combined dynamic and static waves pressures;

F_t is the net breaking wave force per unit length of the structure;

C_p is the dynamic pressure coefficient, ranging from 1.6 to 3.5;

γ_w is the weight of the water;

d_s still water depth at the base of building impacted by the waves.

This procedure assumes that the vertical wall causes a reflection of the waves against a waterward side and that the space behind the vertical wall is dry (therefore with no fluid on the outside of the wall). In the case of non-vertical walls the horizontal component of the breaking wave force shall take into account the vertical angle between non-vertical surface and the horizontal one.

It is important to stress that the proposed preliminary approach is linear; therefore to accurately simulate the dynamic effect of the moving water a detailed analysis considering the fluid-structure interaction in a non-confined space (very difficult to define by means of boundary conditions) should be performed.

Finally, after having determined both hydrostatic and hydrodynamic loads, through a deterministic approach as suggested by WENRA and other International regulatory Bodies, it should be possible to simulate the dynamic behaviour of the whole plant by means of a numerical assessment (adopting suitable FEM code), taking into account adequately the geometrical and material non-linearities as well as the refraction and reflection of waves effects. In conclusion in the following (Fig.26) it is summarized the proposed methodology to be implemented in a second phase of the present study (future development) to analyze and simulate the global plant dynamic response subjected to the tsunami phenomenon.

1. Target Spectrum of SSE by means of time histories (ATH)
2. Characterize the design flood elevation (BFE)
3. Characterize the hydrostatic and hydrodynamic loads (breaking waves loads)
4. Set up and implementation of structural model Water Waves
5. Dynamic Response of the Building and SCC subjected to tsunami
6. Verification of Components behaviour
7. Determination of design needs of flooding/tsunami barriers

Figure 26 – Proposed methodology for future development

6. CONCLUSIONS

A preliminary evaluation of the safety margin of an innovative SMR (e.g. the IRIS one in the performed analyses) subjected to severe events , such as the earthquake (having PGA equal to 0.6 g), the aircraft impact was analysed, using the refined FEM model and the Time History as well as the load function approaches.

Moreover a methodological approach was indicated to preliminary evaluate the tsunami effects, even only from the main tsunami characteristics to be considered.

The strength assessment of the RB structure required considerations on the available geometry, material behaviour (realistic as possible) and constitutive laws of the most important SMR SCCs, aircraft structures and tsunami effects.

The obtained results from the DBBE analyses, in terms of acceleration, displacement and response spectra, highlighted an amplification of the accelerations along the height of the building structure. In the case of DBBE the increase of the accelerations from the ground up to the considered structure did not determine relevant stress value on the RPV.

As for the aircraft analysis concerned the evaluation of the global structural response and of the vulnerability of a reactor building was carried out considering an attack from multiple entry directions of a commercial/military aircraft impacts.

The impact energy determines the progressive failure of the reinforced concrete walls coupled to the local RB wall penetration and subsequently resulted in a decrease of the accelerations propagated up to the inner containment vessel. Nevertheless it is important to highlight that far/away from the impact area the overall stability of containment structure seemed to be ensured.

Finally a methodology to determine the maximum pressure and the net force resulting from a normally incident breaking wave, in the hypothesis of limited depth in size, acting on a rigid vertical wall was predicted on the basis of the available references.

Future study developments of the tsunami breaking water waves impact adopting suitable FEM model seem necessary to correctly evaluate NPP containment system performances.

REFERENCES

1. NRC, Earthquake Engineering Criteria for Nuclear Power Plants, 10 CFR 50.
2. <http://www.world-nuclear.org/>
3. IAEA, Design Features to Achieve Defence in Depth in Small and Medium Sized Reactors, IAEA Nuclear Energy Series Report NP-T-2.2, Vienna (2009)
4. M. D. Carelli et al., The Design and Safety Features of the IRIS Reactor, Nuclear Engineering and Design, 230, 151-167 (2004).
5. J. D. Riera, On the stress analysis of structures subjected to aircraft impact forces, Nuclear Engineering and Design, Vol. 8, Issue 4, 415-426, 1968.
6. Y. Crutzen, J. Reyneu, Disintegration of shell structures under violent dynamic loading conditions, 7th SMIRT, 1983.
7. H. Abbas et al., Aircraft crash upon outer containment of nuclear power plant, Nuclear Engineering and Design, 160, 13-50, 1996.
8. U.S. NRC R.G. DG-1176, Guidance for the assessment of beyond-design-basis aircraft impacts, July 2009.
9. T. Sugano et al., "Local Damage to Reinforced Concrete Structures Caused by Aircraft Engine Missiles: Part 2. Evaluation of Test Results" Nuclear Engineering and Design, Vol. 140, 407-423, 1993.
10. Wolf, J.P., Bucher, K.M., Skrikerud, P.E., 1976. Response of equipment subjected to aircraft impact. Nucl. Eng. Des. 47, 169-193.
11. A.K. Ghosh, Assessment of earthquake-induced tsunami hazard at a power plant site, Nuclear Engineering and Design 238 (2008) 1743–1749.
12. Chanson, H. (2005). Le Tsunami du 26 décembre 2004: un phénomène hydraulique d'ampleur internationale. Premiers constats. La Houille Blanche, Paris, 2, 25-32.
13. F. Leone et al., "A spatial analysis of the December 26th, 2004 tsunami-induced damages: Lessons learned for a better risk assessment integrating buildings vulnerability", Applied Geography 31 (2011) 363-375.
14. Papadopoulos, G., & Imamura, F (2001). A proposal for a new tsunami intensity scale. ITS 2001 Proceedings, Session 5, Number 5-1, 569-577.
15. ASCE Standard, Minimum design loads for buildings and other structures, 2010; ASCE/SEI 7-10.