



Agenzia nazionale per le nuove tecnologie, l'energia
e lo sviluppo economico sostenibile



Ministero dello Sviluppo Economico

RICERCA DI SISTEMA ELETTRICO

Documenti tecnici contrattuali per la realizzazione delle 18 casse di contenimento di JT-60SA

A. Cucchiaro, P. Rossi, L. Di Pace, G. Brolatti



Report RdS/2012/255

DOCUMENTI TECNICI CONTRATTUALI PER LA REALIZZAZIONE DELLE 18 CASSE DI CONTENIMENTO DI JT-60SA

A. Cucchiaro, P. Rossi, L. Di Pace, G. Brolatti (ENEA)

Settembre 2012

Report Ricerca di Sistema Elettrico

Accordo di Programma Ministero dello Sviluppo Economico - ENEA

Area: Governo, gestione e sviluppo del sistema elettrico nazionale

Progetto: 1.3.2 Fusione nucleare: Attività di fisica e tecnologia della fusione complementari ad ITER

Responsabile del Progetto: Aldo Pizzuto, ENEA

Indice

Sommario	4
<i>Introduzione</i>	<i>5</i>
Documenti tecnici contrattuali	5
<i>Specifica tecnica</i>	<i>6</i>
<i>Specifica manageriale</i>	<i>6</i>
<i>Disegni costruttivi.....</i>	<i>6</i>
Conclusioni	6
Abbreviazioni ed acronimi	7

Sommario

L'ENEA è impegnato nella Costruzione, Collaudo e Spedizione a Naka del Magnete Toroidale della Macchina Tokamak JT-60SA e di parte dei sistemi di alimentazione elettrica. Delle 18 bobine toroidali che costituiscono il magnete, 9 saranno realizzate dall'ENEA e 9 dal CEA Francese.

L'ENEA è responsabile della fornitura in kind di:

- Nove delle 18 bobine di NbTi che costituiscono l'intero magnete;
- Le casse di contenimento per tutte le 18 bobine costituite da componenti in acciaio austenitico;
- Le alimentazioni elettriche per un totale di 8 alimentatori ad alta tensione e corrente con relativi interruttori e trasformatori più quattro sistemi di interruzione della corrente continua.

I contratti per la realizzazione delle bobine sono stati già affidati rispettivamente da ENEA ad ASG Superconductors e dal CEA ad Alstom, mentre il contratto di fornitura delle casse di contenimento delle 18 bobine è stato affidato alla ditta Walter Tosto.

Il presente documento riporta i documenti tecnici contrattuali definitivi (disegni costruttivi, specifiche tecnica e manageriale) consegnati alla ditta Walter Tosto in sede di kick-off meeting (KOM) il 12/7/2012 e relativi al contratto per la realizzazione delle 18 casse di contenimento di JT-60SA.

Introduzione

Europa, Cina, Corea del Sud, India, Giappone, Federazione Russa e Stati Uniti hanno riunito i loro sforzi nel progetto ITER (International Thermonuclear Experimental Reactor) in costruzione a Cadarache in Francia.

A margine dei negoziati per decidere il sito di ITER, Europa e Giappone hanno ratificato un accordo di collaborazione denominato "Broader Approach" (BA).

L'accordo, al quale l'Italia ha aderito, consiste in una serie di attività sia di fisica che di tecnologia che prevedono realizzazioni prototipiche di alto contenuto tecnologico e, tra gli altri, la realizzazione di un esperimento tipo tokamak denominato JT60-SA, che sarà installato a Naka nella Torus Hall che attualmente ospita il Tokamak JT-60U.

Per finanziare l'accordo, Francia, Italia, Spagna, Germania e Belgio hanno offerto dei contributi finanziari per fornire 'in kind'.

L'ENEA è impegnato nella Costruzione, Collaudo e Spedizione a Naka del Magnete Toroidale della Macchina Tokamak JT-60SA e di parte dei sistemi di alimentazione elettrica. Delle 18 bobine toroidali che costituiscono il magnete, 9 saranno realizzate dall'ENEA e 9 dal CEA Francese.

L'ENEA è responsabile della fornitura in kind di:

- Nove delle 18 bobine di NbTi che costituiscono l'intero magnete;
- Le casse di contenimento per tutte le 18 bobine costituite da componenti in acciaio austenitico;
- Le alimentazioni elettriche per un totale di 8 alimentatori ad alta tensione e corrente con relativi interruttori e trasformatori più quattro sistemi di interruzione della corrente continua.

I contratti per la realizzazione delle bobine sono stati già affidati rispettivamente da ENEA ad ASG Superconductors e dal CEA ad Alstom, mentre il contratto di fornitura delle casse di contenimento delle 18 bobine è stato affidato alla ditta Walter Tosto.

Il kick-off meeting (KOM) per l'inizio delle attività contrattuali si è svolto a Frascati il giorno 12/7/2012, in occasione del quale è stata formalmente consegnata la documentazione tecnica contrattuale da ENEA alla ditta.

In questo documento viene riportata la suddetta documentazione tecnica.

Documenti tecnici contrattuali

L'affidamento della fornitura delle 18 casse di contenimento delle bobine toroidali di JT-60SA è stato effettuato attraverso una procedura di gara, che è iniziata nel mese di marzo 2012 con l'invio delle lettere di invito.

In quella fase ENEA aveva prodotto un set di documentazione tecnica, da allegare alle lettere di invito e alle richieste di offerta, che consisteva in:

- Specifica tecnica (Rev. 0);
- Specifica manageriale (Rev. 0);
- Disegni costruttivi (di gara, for tender).

La fase di aggiudicazione del contratto si è conclusa nel mese di luglio 2012, con l'attribuzione del contratto alla ditta Walter Tosto di Chieti. L'inizio delle attività è stato formalmente dichiarato il 12/7/2012, data in cui si è tenuto a Frascati il kick-off meeting (KOM) in occasione del quale è stata formalmente consegnata la documentazione tecnica contrattuale da ENEA alla ditta.

Durante il periodo di aggiudicazione è stato ottimizzato il progetto complessivo della bobina toroidale, ENEA ha quindi perfezionato la documentazione tecnica di gara con una revisione della specifica tecnica e dei disegni costruttivi.

In sede di KOM, ENEA ha quindi consegnato alla ditta Walter Tosto un set di documentazione tecnica contrattuale, consistente nei seguenti documenti definitivi:

- Specifica tecnica (Rev. 1);
- Specifica manageriale (Rev. 0);
- Disegni costruttivi (contrattuali, for contract).

La specifica tecnica è stata aggiornata con una minima revisione del materiale di costruzione delle casse. In particolare, e, su specifica richiesta di Fusion for Energy (F4E), è stata revisionata la composizione chimica dell'acciaio AISI 316 con una minima diminuzione dei tenori massimi di alcuni elementi di lega quali cromo e nichel.

I disegni sono rimasti sostanzialmente gli stessi per componenti e geometria ma sono stati aggiornati con l'introduzione del tubo di raffreddamento dell'elio anche nei mock-ups e con la revisione di alcuni sovrametalli e rugosità.

La specifica manageriale contrattuale è rimasta la stessa prodotta in fase di gara.

Specifica tecnica

Si allega a questo documento la specifica tecnica (Rev. 1):

- JT60SA-Technical Specification for supply of 18 sets of Toroidal Field Coil Casing Components; SPT-JT60CC-01R1.

Specifica manageriale

Si allega a questo documento la specifica manageriale (Rev. 0):

- JT60SA-Management Specification for supply of 18 sets of Toroidal Field Coil Casing Components; QMS-JT60CC-01

Disegni costruttivi

Si allegano a questo documento i seguenti disegni:

Set di disegni (ASG type, Rev. del 18/06/2012)

- 010301-503000 Casing Components
- 010301-503001 Straight Leg Outboard
- 010301-503003 Curved Leg Outboard
- 010301-503002 Straight Leg Inboard
- 010301-503004 Curved Leg Inboard
- 010301-503005 Miscellaneous Components
- 010301-503006 Inner He Cooling Layout
- 010301-503007 Mock-up straight beam 1 m long
- 010301-503008 Mock-up straight sample 50 cm long

Set di disegni (ALSTOM type, Rev. del 18/06/2012)

- 010301-503100 Casing Components
- 010301-503101 Straight Leg Outboard
- 010301-503103 Curved Leg Outboard
- 010301-503102 Straight Leg Inboard
- 010301-503104 Curved Leg Inboard
- 010301-503105 Miscellaneous Components
- 010301-503106 Inner He Cooling Layout
- 010301-503107 Mock-up straight beam 1 m long
- 010301-503108 Mock-up straight sample 50 cm long

Conclusioni

Il presente documento riporta i documenti tecnici contrattuali definitivi (disegni costruttivi, specifiche tecnica e manageriale) consegnati alla ditta Walter Tosto in sede di KOM il 12/7/2012 e relativi al contratto per la realizzazione delle 18 casse di contenimento di JT-60SA.

Abbreviazioni ed acronimi

ITER	International Thermonuclear Experimental Reactor
BA	Broader Approach
KOM	kick-off meeting
F4E	Fusion for Energy

JT60SA-Technical Specification for supply of 18 sets of Toroidal Field Coil Casing Components.

		<i>P. Rossi</i>		
1	12/07/2012	P. Rossi V. Tomarchio	P. Rossi Di Pace	A. Cucchiaro
0	22/11/2011	L. Reccia V. Tomarchio	P. Rossi	A. Cucchiaro
Rev.	Date	Author	Reviewer	Approver

Chronology and history of revisions

Rev.	Date	Description
0	22/11/2011	First issue
1	12/07/2012	Front page correction Minor update of the chemical composition (par. 4.1)

Table of Contents

Abbreviations and Acronyms.....	4
1 Introduction	5
1.1 Background Information on the JT-60SA TF Magnet	5
1.2 The TF magnet assembly	5
1.3 The TF coil casing	5
2 Scope of Supply	7
3 Deliverables	7
3.1 TF Coil Casing Components	7
3.2 Mock-ups	8
3.3 Quality Documentation	10
3.4 Reference documents.....	10
3.4.1 Codes and standards.....	10
3.4.2 Drawings.....	11
3.5 Responsibilities	11
4 Manufacturing	12
4.1 Materials.....	12
4.2 Identification	13
4.3 General Requirements.....	14
4.3.1 Workshop personnel.....	14
4.3.2 Cleanliness.....	14
4.3.3 Handling	14
4.4 Construction	15
4.4.1 Technical Requirements.....	16
4.4.2 Tooling Requirements	16
4.4.3 Acceptance Testing/Other Measurements	16
4.5 Welding.....	17
4.6 Machining	18
4.6.1 Technical Requirements.....	19
4.6.2 Tooling Requirements	19
4.6.3 Acceptance Testing/Other Measurements	19
4.7 Weld grooves preparation.....	20
4.7.1 Technical Requirements.....	20

4.7.2	Tooling Requirements	20
4.7.3	Acceptance Testing/Other Measurements	21
4.8	Installation of the cooling channel	21
4.8.1	Technical requirements.....	21
4.8.2	Tooling Requirements	22
4.8.3	Welding	22
4.8.4	Acceptance Testing/Other Measurements	22
5	Delivery Requirements	22
5.1	Packaging	23
5.2	Destination	23
6	Documentation	23
6.1	Quality plan and control plan	24
6.2	Production Process description	24
6.3	Validation program.....	24
6.4	Validation Report for all the special process.....	25
6.5	Acceptance Data Package.....	25

Abbreviations and Acronyms

CICC	-	Cable In Conduit Conductor
CQMS	-	Common Quality Management System
DP	-	Double Pancake
DT	-	Destructive Test
ENEA	-	Italian National agency for new technologies, Energy and sustainable economic development
EUHT	-	European Union Home Team
F4E	-	Fusion for Energy (European Implementing Agency for JT-60SA)
HAZ	-	Heat Affected Zone
DMS	-	JT-60SA Document Management System
JAEA	-	Japan Atomic Energy Agency
JT-60SA	-	JAEA Tokamak 60 Super Advanced
NCR	-	Non Conformance Report
NDT/NDE	-	Non Destructive Test/Exams
PID	-	Plant Integration Document
pWPS	-	Preliminary Welding Procedure Specification
TF	-	Toroidal Field
TFC	-	Toroidal Field Coil
WPS	-	Welding Procedure Specification
WPQR	-	Welding Procedure Qualification Report

1 Introduction

1.1 Background Information on the JT-60SA TF Magnet

The JT-60SA is a fully superconducting tokamak capable of confining break-even equivalent class high-temperature deuterium plasmas. The mission of the JT-60SA project is to contribute to the early realisation of fusion energy by addressing key physics issues for ITER and DEMO.

The magnetic system of JT-60SA is composed of 18 toroidal field coils, 4 central solenoid and 6 equilibrium field coils. All of these coils are superconducting, cooled by supercritical helium at 4.4 K and thermally protected in a cryostat.

The plasma magnetic confinement will be provided by a set of eighteen D-shaped NbTi coils, driven at a nominal current of 25.7 kA, thus producing a maximum magnetic field on the conductor of about 5.65 Tesla. Each of the 18 coils will be more than seven meters tall, and the whole magnet will be able to store an overall energy of 1.06 GJ. The weight of each set of TF Coil Casing will be 9 t and the overall weight of the complete TF magnet will not exceed 380 t.

1.2 The TF magnet assembly

The TF magnet assembly requires that the following tasks are achieved:

1. Manufacturing of the TF coil casing.
2. Manufacturing of the conductors
3. Winding and impregnation of the TF coil winding pack.
4. Embedding of the winding pack in the TF coil case component.
5. Transverse and longitudinal final welding.

The subject of this specification is the manufacture of the TF Coil Casing Components that basically regards only the step 1. Nevertheless, some technical details and features of the casing parts strongly impact on the activities listed in the steps 3, 4 and 5, that will be covered by other contractors.

Consequently, the supply of mock-ups and the welding preparation on either the mock-ups and the final Casing Components, are an integral part of this contract, since they are preparatory for the whole TF magnet assembly process.

1.3 The TF coil casing

The TF coil casing mission is to embed and support the superconducting winding pack. Due to the embedding and assembling procedure, it has to be realized in 4 main parts intended to be welded at the end of the assembly procedure. Figure 1 depicts the lay-out of the casing divided into its parts.

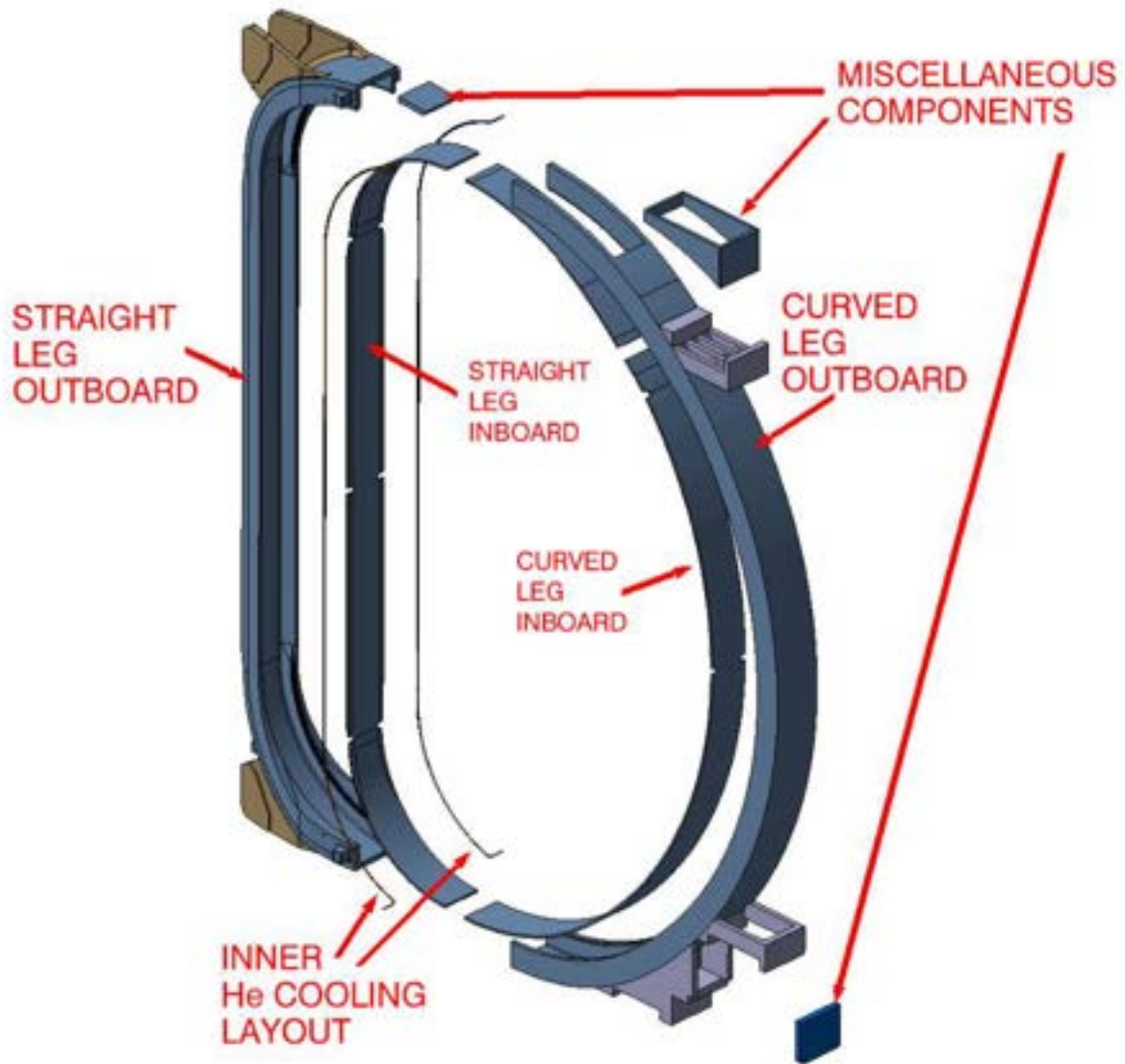

Figure 1 TF Coil casing components

2 Scope of Supply

The Contractor is asked to supply:

1. Two sets of mock-ups as described in §3.2.
2. Two groups of 9 complete sets each of TF Coil Casing Components.
3. The technical and quality documentation related to the manufactured items and the production process relevant aspects.

3 Deliverables

3.1 TF Coil Casing Components

The Contractor must provide **18 sets of TF Coil Casing Components**, divided in two groups of 9 sets each. Each group will be delivered to a different TF coil manufacturer where the integration of the Winding Pack will be carried out. The two TF coil manufacturers are ASG Superconductors and Alstom.

Each TF Coil Case consists of 4 main parts: straight leg outboard, straight leg inboard, curved leg outboard and curved leg inboard. All the details needed for the manufacturing of all these parts are reported in the following referred drawings.

The items as shown in Table 3-1 are included in the scope of supply for a single set of Coil Casing Components.

Item	Description	Quantity (1 set)	Quantity (ASG)	Quantity (ALSTOM)
1	Straight Leg Outboard	1	9	9
2	Curved Leg Outboard	1	9	9
3	Straight Leg Inboard	1	9	9
4	Curved Leg Inboard	1	9	9
5	Miscellaneous Components	1	9	9
6	Inner He Cooling Layout	2	9x2	9X2
7	Mock up components as described in §3.2		1 set	1 set
8	Acceptance Data Package	1	9	9
9	Full set of packaging for the complete TF coil casing	1	9	9

Table 3-1 - Scope of supply

As far as the TF Coil is concerned (see Figure 1), two different welding are required:

1. A welding between the Straight leg and the Curved leg both on the inboard and the outboard side (Transverse welding). The thickness to be welded is about 50mm.
2. A welding between the outboard and the inboard part, both for Straight and Curved legs (Longitudinal welding) . The thickness to be welded is about 20mm.

These welding will be performed during the final assembly and are not part of this contract. Nevertheless, the TF Coil Casing Components have to be supplied with the proper preparation which shall be agreed between the Contractor and the two TF Coil manufacturers, basing on the welding procedure defined by the latter.

3.2 Mock-ups

The casing will be delivered by the Contractor to the Company in charge of inserting the winding pack into the coil casing, as a number of separate prefabricated components.

After insertion and wedging of the winding into the casing, the transverse and longitudinal welding of the closure plates will be performed by the winding pack manufacturers.

In order to define the welding process to be followed, it is needed to perform some tests and to qualify the welding procedure for both the transverse weld and the cover (longitudinal) weld.

Demonstration of the quality of this weld will be achieved by the winding pack manufacturer through the use of mock-ups. In order for the winding pack manufacturer to carry out the welding tests, representative samples must be prepared by the casing contractor. The casing contractor shall

manufacture and deliver the required components for the winding pack contractors to manufacture appropriate mock ups.

The required components are:

- 1 beam for ASG and 1 beam for Alstom: 1 metre long at full scale, representative of the casing cross section in the straight leg, i.e. 'V' shaped; including a separate flat cover plate (Figure 2).
- 2 samples for ASG and 2 samples for Alstom: 50 centimetre long, representative of the casing cross section in the curved leg; including flat cover plates (Figure 3).

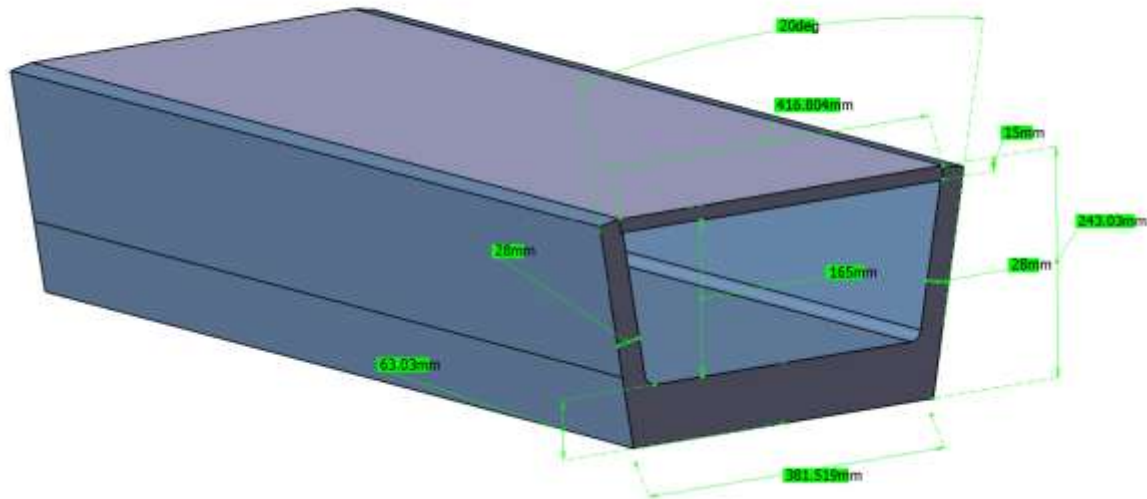

Figure 2 - Straight beam 1 metre long Mock-up

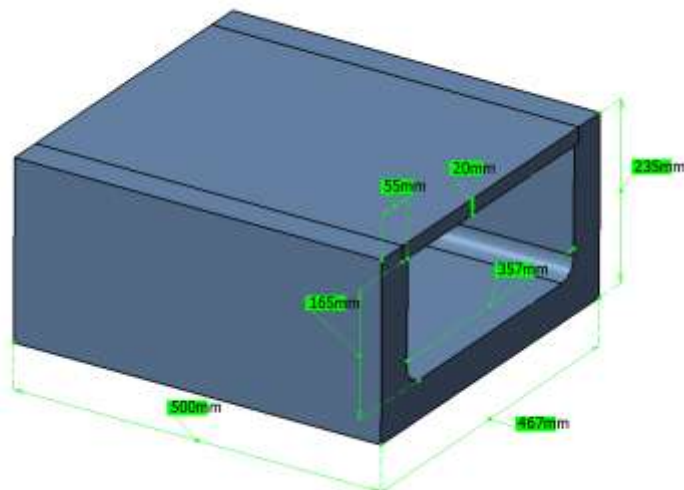

Figure 3 - Sample 50 cm long

3.3 Quality Documentation

The Contractor must provide complete documentation both for the manufacturing process and the deliveries. The documents have to be issued respecting the following schedule:

Prior to start the manufacturing of the mockups:

1. Quality Plan
2. Production Process description
3. Validation program.
4. Control Plan

During the manufacturing of the Mock-ups:

5. Chemical analysis, destructive and non destructive test reports for the raw material, the sub-assembly parts and welding of the Mockups.

Linked to the delivery of the mock-ups:

6. Validation Report for all the special process related to the mock-up construction
7. Acceptance data package for the mockups.

Prior to the manufacturing of the Casing Components

8. Validation Report for all the special process.

During the manufacturing of the Casing Components:

9. Chemical analysis, destructive and non destructive test reports for the raw material and the parts used to assemble the Casing Components.
10. Reports of NDT during production welding.

Linked to the delivery of the TF Coil Casing Components:

11. Acceptance data package for TF Coil Casing Components.

Apart of the reports, for all the test performed (both DT and NDT) the Contractor shall also store the relevant output of the test (digital signals time-histories, radiography etc.) on record.

The requirements for these documents will be explained in details throughout this document in the relative proper sections.

3.4 Reference documents

3.4.1 Codes and standards

During execution of the work the following codes and standards in their current revision shall be applied. In particular the following standards shall be applied:

- The ASME code in general for welding and for welding inspection

- The ASME code section IX, PART QW for welding qualification
- The ASME code section IX for welded coupons inspection
- The ASME code section II Part C for welding filler material
- ASTM E45, Method A for inclusion measurement
- JIS Z3119 for analysing ferrite content in raw material or ASTM E562.
- Other codes or standards can be used as long as the compliance with the relevant ASME code is demonstrated beforehand.

3.4.2 Drawings

All the drawings delivered for the construction are listed In Table 3-2 are reported the reference to the single parts drawings.

Drawing number (ASG: CS1 to CS9)	Drawing number (ALSTOM: CS10 to CS18)	Rev	Description
010301-503000	010301-503100		Casing Components
010301-503001	010301-503101		Straight Leg Outboard
010301-503003	010301-503103		Curved Leg Outboard
010301-503002	010301-503102		Straight Leg Inboard
010301-503004	010301-503104		Curved Leg Inboard
010301-503006	010301-503106		Inner He Cooling Layout
010301-503005	010301-503105		Miscellaneous Components
010301-503007	010301-503107		Mock-ups
010301-503008	010301-503108		

Table 3-2 – TF Coil Casing Drawing Numbers.

Since the two TF coil manufacturers have different requirements for the amount of over material required in different locations of the casing two complete sets of drawings are provided, one for each coil manufacturer. The contractor shall take care to these differences in order to supply the proper casing components to each of the two TF coil manufacturing contractors.

3.5 Responsibilities

The Contractor:

- shall develop detailed design of the casing on the base of the preliminary design reported in Table 3-2;

- shall prepare two complete sets of CATIA models and the associated CATIA drawings for the complete Casing Component Set, one for ALSTOM and one for ASG. These models are to be provided prior to manufacture. The models shall then be updated by the Contractor where a design deviation affects the geometry of the components throughout the whole manufacturing process;
- shall inspect the incoming material and guarantee that it fulfill the requirements of this contract;
- shall supply and provide all the Casing Components as required for the fulfillment of the contract;
- shall use sub-contractors only with the authorization of ENEA. In this case the sub contractor shall be indicated in the Quality Plan and the responsibility of the performance and of the compliance of the parts involved in sub-contracting shall be of the Contractor;
- shall be responsible to provide the supply with the proper packaging in order to deliver it perfectly;
- shall ensure that all the Quality requirements are fulfilled and all the Quality Documentation are drawn, filled and signed.

ENEA shall provide the weld preparation drawings and the surface machining specification to the Contractor. Two different set of drawings, one for the ASG casings, the other for the Alstom casings; will be prepared based on the requirements of the two winding pack manufacturers.

4 Manufacturing

The coil casing components will finally provide the necessary containment and support to the 18 winding packs which will be embedded inside them.

Each single set consists of four main sub-components, as described in Table 3-2, which are represented together in exploded view of the final assembled casing in drawing number 010301-503000 for ASG and 010301-503100 for Alstom

The manufacture of the TF coil casing includes:

1. Construction of the components
2. Machining of the internal surfaces
3. Weld grooves preparation
4. Installation of cooling channel

The mock-up manufacturing is based on a similar procedure following steps 1, 2 and 3.

4.1 Materials

Materials purchased by the manufacturer in plate form shall be made to ASTM A-480 and ASTM A-240.

Forgings shall be made to ASTM A-484 and A473-01.

The coil casings shall be made from 316L austenitic stainless steel with the following specific requirements:

- chemical composition as given in Table 4-1 (the manufacturer should note that this specification requires closer control of the cobalt and nitrogen content than standard 316L).
- relative magnetic permeability ≤ 1.05 at ~ 500 Oe at RT
- grain size index ≥ 2 (ASTM E112-88)

Element	Min	Max	
C	0.000	0.030	% weight
Si	0.000	0.750	% weight
Mn	0.000	2.000	% weight
P	0.000	0.035	% weight
S	0.000	0.015	% weight
N	0.08	0.110	% weight
Cr	17.000	18.500	% weight
Mo	2.500	3.000	% weight
Ni	12.500	14.000	% weight
Co	0.000	500	ppm

Table 4-1: Chemical composition of casing material

The mechanical requirements for the material at room temperature are specified in the corresponding ASTM code indicated above.

All materials must be certified as complying with the requirements of this section. In addition samples prepared according to both ASTM E1450-09 (tensile) and JIS Z 2284 (fracture toughness) from 10% of all plates and 10% of all forgings must be provided to ENEA for independent testing.

The location of these samples will be provided by ENEA.

4.2 Identification

Each part (plate, sheet, strip) has to be marked by stamping or electric pencil in order to identify:

1. Supplier
2. Batch/Cast number
3. Lot/Forging number
4. Type/Grade of material

4.3 General Requirements

4.3.1 Workshop personnel

All personnel involved in any manufacturing operation shall be informed of the special requirements of the work associated with the TF Coil Casing Components manufacture. In particular:

- It is essential that workshop personnel do not deviate in any way from the design, or make repairs to resolve any manufacturing issue, without ENEA involvement. As such, there must be an open channel of communication between workshop personnel and ENEA.
- All personnel entering the area of the TF Coil Casing Components manufacture shall be formally informed of the importance of the points as noted in 4.3.2.
- All welders must be qualified for the welding technique chosen. A copy of the welder's license shall be provided.
- Personnel performing NDT has to be qualified according to reference codes.
- Personnel performing welding inspection has to be qualified according to reference codes.

In relation to the above points, ENEA shall be present while workshop personnel are informed of these requirements.

4.3.2 Cleanliness

All manufacturing operations shall be performed under clean conditions. Particular care must be taken to ensure the following:

- Any other non related process which may be carried out in the vicinity of manufacture of the TF Coil Casing Components will not adversely affect the manufacture of the TF Coil Casing Components.
- No painted or unpainted ferromagnetic material shall be allowed to be in contact with the TF Coil Casing Components. No ferromagnetic material dust or debris should be allowed in the manufacturing area of the TF Coil Casing Components.
- All the tools used for the manufacturing of the TF Coil Casing Components, including clamps, hammers, brushes, welding tools, support, handlers, lifting and moving tools, must be suitable for Stainless austenitic steel.

All the details about the cleanliness management shall be described in the Production Process Description.

4.3.3 Handling

During the manufacture of the TF Coil Casing Components, many handling operations are required. In order to minimise the risk of damage to any components due to handling operations being carried out, it is expected that the Contractor will pay close attention to all expected handling operations prior to commencement of the operation.

With reference to and meeting the requirements of 6.1, the Contractor shall submit a Detailed Procedure for all of the handling operations which are expected to be carried out during the

manufacturing process. In developing the Detailed Procedures, the Contractor will consider the complete manufacturing process, and will:

- Attempt to carry out all manufacturing processes with a minimum number of intermediate handling operations;
- Install suitable supports around the components to be handled to ensure that the components do not undergo plastic deformation;
- Ensure that all pipes are protected from mechanical damage;
- Ensure that the cooling channel ends are sealed and protected from the ingress of particulate or liquid material;
- Not weld any equipment to any component of the TF Coil Casing Components e.g. lifting equipment;
- Ensure that there is no direct contact between painted or unpainted ferritic steel and any of the TF Coil Casing Components;
- Design and manufacture appropriate jigs and fixtures for all handling processes;

The list of Detailed Procedures depends on the chosen manufacturing process(es), however, it is expected that a Detailed Procedure will be submitted for all the handling procedures including:

- Lifting of all casing components;
- Turning of all casing components;
- Storage of all casing components;
- Moving of the assembly during the preparation for the shipment.

4.4 Construction

A number of raw materials will be procured by the Contractor and will be assembled into all casing components. The raw materials may be in form of plates, bars, tubes, ingots and the like. The Contractor remains responsible for choosing the construction technology, either forging, automatic welding, machining or similar, which best suits their manufacturing processes. However, for all processes, the Contractor shall submit a Detailed Procedure for endorsement by ENEA.

The construction of the casing components will include:

- Receipt of the raw materials (plates, ingots, tubes),
- Incoming inspection of all material certificates,
- Acceptance tests on raw material, sampling the needed specimens,
- Forging of the ingots into formed parts, if required,
- Bending/rolling of plates,
- Acceptance tests on forged parts and/or plates, sampling the needed specimens,
- Welding of plates/formed parts into components,
- Stress relieving, if needed,

- Performing of NDT and
- Cleaning and degreasing of the constructed components, sandblasting if required.

4.4.1 Technical Requirements

- The Contractor shall organize a design review with the presence of ENEA in order to approve the detailed design.
- The Contractor shall verify, after receipt of each batch of raw materials, that the material certificates are duly filled and complete, and that the requirements reported in 4.1 are met.
- The Contractor shall provide the facilities, either internal or by sub-contractors, needed for the successful construction of the casing components: such facilities include, but are not limited to:
 - Welding stations and equipment (for the welding processes chosen by the Contractor)
 - Drop or press forging equipment (where forged parts must be procured)

In case of sub-contracting, ENEA reserves the right to inspect the sub-contractor's facilities during production of the casing components.

The Contractor shall combine the raw materials in the casing components using the process of their choice, being it either automatic/manual welding of smaller plates, or forging of large sections. Whatever the choice, it has to be described in the Quality plan and control plan by means of the needed Detailed Procedure and ENEA reserves the right to approve the process and to inspect the facility which carries it out.

- The Contractor has to prepare detailed drawings of the assembly and of the parts to be welded including chamfers.
- An overview of the Casing Components is given in drawing 010301-503000. The main structural parts of each casing set are the Straight Leg Outboard (drawing 010301-503001) and Curved Leg Outboard (drawing 010301-503003). These will be welded together by each of the two Coil Manufacturers to provide a supporting structure for the Winding Pack. The casing closure is completed by the welding of the Straight Leg Inboard (drawing 010301-503002) and Curved Leg Inboard (drawing 010301-503004).

4.4.2 Tooling Requirements

In order to satisfactorily construct the casing components, the following is required:

- Suitable lifting equipment to handle the raw materials.
- Suitable supports for storage and preparation of the raw materials.
- Suitable jigs and fixtures to allow a controlled welding process and to limit distortions to a minimum.
- Tooling needed to manufacture and transport the sub-assembly of the casings.

4.4.3 Acceptance Testing/Other Measurements

If the casing components is obtained by welding parts, the non destructive test specified in the welding requirements have to be carried out. Details about welding are reported in 4.5.

The 100% of the parts obtained from forging ingot or bending/cutting plates have to be subjected to Acceptance test.

Firstly a visual examination have to be carried out to verify that cracks, scratch and, in general, surface defects are not present. Furthermore the parts are also required to pass ND exams. The Contractor will choose the more appropriate technique (radiographic test or ultrasonic test or other). The NDT procedure will need to be approved by ENEA and will be part of the Production Process Description.

The Acceptance Criteria have to be the defined applying the relevant International Standard depending by the process used (forging, bending, cutting etc.). The reference Standard, as well as the description of the control itself, shall be clearly indicated in the relevant Detailed Procedure.

The opportunity of repairing a defect shall be considered case by case and shall ONLY be carried out AFTER agreement with ENEA. Repaired parts shall be submitted to the acceptance test once again.

After final machining of the casing components, the following checks shall be carried out:

- Geometrical survey of the inner surfaces of the casing inboard and outboard components. The survey could be carried out by using go-no go gauges, to check the channel widths, and/or 3D measuring devices (like touch probes, measuring arms, laser trackers, laser scanners and the like) to check for the flatness of the internal surfaces and the straightness of the internal channel profile.

4.5 Welding

"Weld quality shall be assured by the general provisions of the ASME Boiler and Pressure Vessel Code ("the ASME Code"). The following requirements apply to all welds:

1. All welding procedures must be qualified before welding commences according to the procedure given in Section IX, Article II, of the ASME Code. This means that a procedure is written for each weld to be performed, sample welds must then be performed with the as-supplied base material and filler material and subjected to tests to determine the chemical composition and mechanical properties of the joint. Both the procedure and the qualification of the procedure must be documented as described in the same article of the ASME Code. The coil cases will operate at 4K and all materials must comply with the toughness requirements of Section VIII Division 2 Part 3.11.4 of the ASME Code.
2. All welding personnel (welders and welding operators) must be qualified according to the procedure in Section IX of the ASME Code. This means that the people carrying out the work must have welded test coupons which have passed the inspections as described in Section IX, Article III.
3. Every weld must be subject to 100% visual inspection, following the procedure described in Section V, Article 9 of the ASME Code.
4. Every weld must be subject to 100% surface inspection for cracks using a dye penetrant technique, performed according to Section V, Article 6, T641 of the ASME Code. The fluids used shall be suitable for vacuum components.
5. Every weld must be subject to 100% volumetric inspection by radiography or, where this is not possible, by ultrasonic inspection. These techniques must be applied as described in Section V, Article 2 and Article 4 respectively of the ASME Code. In addition, where ultrasonic

inspection is used in lieu of radiographic examination, it must be carried out in accordance with ASME VIII Division 2 Section 7.5.5.

6. The acceptance criteria to be applied are those given in Section VIII, Division 2, Part 7.5 of the ASME Code, with the additional requirement that the largest permissible defect shall be smaller than 5 mm² in area with an aspect ratio of 3:1.

In addition to the requirements of the ASME Code, for qualification purposes the following destructive tests shall be performed:

- Tensile test at room temperature, 2 specimens;
- Impact test at room temperature, 2 specimens;
- Tensile test at 4K, 2 specimens (2 specimens will be delivered to Fusion for Energy that will carry out the test under its responsibility);
- Metallographic test: 1 macroexamination, 1 microexamination.
- For all welded parts the Contractor shall:
- Prepare detailed drawings of the assembly and of the parts to be welded including chamfers;
- Define a pWPS, qualify the process (also drawing a WPQR) and finalize the WPS to be approved by ENEA. The pWPS must include all the relevant parameters that can impact the characteristics of the welded joint, as prescribed by the reference rule.

4.6 Machining

The roughness of the internal surfaces is a key aspect in the winding pack embedding and impregnation. For this reason the casing components internal surface must be machined with care in order to achieve the specified levels of dimensional and geometrical tolerances as specified in the drawings.

External surfaces must be machined to remove excess material up to the values specified in the following sections.

Machining of the casing components internal surfaces includes:

- Pre-machining of the channels inside the Straight Leg Outboard and Curved Leg Outboard components.
- Stress relieving of the components, as required by the chosen manufacturing process.
- Final machining of the channel inside the Straight Leg Outboard and Curved Leg Outboard components.
- Cleaning and degreasing of the machined components.

4.6.1 Technical Requirements

- The geometry and the dimensional requirements of the internal casing surfaces are detailed in the Straight Leg Outboard drawing 010301-503001 and in the Curved Leg Outboard drawing 010301-503003.
- It is suggested that the Contractor shall execute the machining of the components in two passes: the first coarse pass should be used to remove most of the material, from both the internal and (if necessary) external surfaces of the fabricated casing components, and it shall be followed by a stress relieving procedure in order to remove residual stresses due to welding and machining. After the stress relieving, the fine machining of the casing internal faces can be carried out. Modifications to this sequence of steps (coarse machining, stress relieving, fine machining) can be proposed by the Contractor, but ENEA reserves the right to review the procedure and accept the proposal.
- The Contractor shall remove, after the fine machining phase, all traces of grease and dirt from the machined components, and provide a suitable space for their storage in the time lapse prior to the following manufacturing steps.
- A Detailed Procedure is required describing the complete machining process. As a minimum, the following points shall be covered in the Detailed Procedure:
 - Details of the chosen machine centre such as size, capacity and number of degrees of freedom of the cutting tool.
 - The proposed orientation of the coil for each setup.

4.6.2 Tooling Requirements

In order to satisfactorily machine the casing components, the following is required:

- A numerically controlled milling machine, able to machine each casing segment with an accuracy of at least 0.1 mm, possibly with the component fixed in a single position, shall be used for the machining of the casing components. Alternative solutions may be proposed, but ENEA reserves the right to review the procedure and accept the proposal.

4.6.3 Acceptance Testing/Other Measurements

After machining of the casing components, for those surfaces which were exposed by the machining passes, the following checks shall be carried out:

- Visual inspection to verify that the external surface is free of defects.
- The Contractor may execute the inspection of the non-machined surfaces, as reported in 4.4.3, at this same point in time. This choice has to be documented in the official test results.
- A geometrical survey of the machined surfaces to confirm compliance with the values specified in drawing number 010301-503001 (Straight Leg Outboard) and in drawing number 010301-503003 (Curved Leg Outboard).
- A three dimensional mapping of the inner surface to be carried out with the proper method (laser tracking or equivalent). This will be supplied to the TF coil manufacturer in order to compare the map with the winding pack one and support the embedding operation.

4.7 Weld grooves preparation

The machined casing components must be prepared for the welding operations which will be carried out during integration of the Winding Pack in the casing. These operations, that will be carried out by the TF Coil manufacturer contractor, include:

- Execution of transverse welds, which are relatively thick (~ 50 mm) butt welds applied on the three thick sides of the casing cross section, between the inboard and outboard casing components.
- Execution of longitudinal welds, which are relatively thin (~ 20 mm) fillet or butt welds applied between the casing components and their closure plates.

The Contractor shall take care of the preparation of the parts to be welded as agreed with the TF Coil manufacturers. Before the manufacturing of the first complete set of casing components ENEA will supply the relevant drawings basing on the TF coil manufacturers needs. Being two different contractors in charge for the final assembly of the magnet it is expected that two different sets of drawings will be supplied clearly marked with the relevant winding pack manufacturer's name.

Weld grooves preparation will include:

- Machining of the inboard and outboard casing components
- Machining of the inboard and outboard closure plates

4.7.1 Technical Requirements

The precise details of the weld grooves shall be agreed with the TF Coil Manufacturer Contractors under the ENEA supervision, prior commencing of the execution, on the basis of the requirements coming from the coil manufacturer. Since there are two different coil manufacturers, each taking care of nine coils, it is possible that two different sets of weld preparations will be requested, on the basis of the individual preference of the manufacturers. It is expected that the TF coil manufacturers will work with the Contractor to define the weld preparation detail to suit their manufacturing process.

The TF coil casing welding design will be agreed with the TF Coil Manufacturer under ENEA coordination. Consequently the preparation of the grooves, including the chamfer shape and dimension, the surface condition and extra material must be compliant with the foreseen weld execution method.

The location of the weld grooves is indicated in drawing number 010301-503001 (Straight Leg Outboard) and in drawing number 010301-503003 (Curved Leg Outboard).

4.7.2 Tooling Requirements

In order to satisfactorily prepare the weld grooves, the same machining requirements reported in 4.6.2 must be met.

4.7.3 Acceptance Testing/Other Measurements

After machining of internal surfaces the Contractor shall perform geometrical checks of all weld grooves, either by using rigid templates or 3D measuring devices thus ensuring that the geometry, the dimension and the surface roughness meet the TF Coil assembly Contractor requirements.

4.8 Installation of the cooling channel

The Straight Leg Outboard casing component is equipped with two internal cooling channels, one per side, which are first fitted in curved grooves machined in the component curved sections and then welded all along the straight part of the component itself. Each channel has two termination pipes, of round section, which penetrate the component side wall through slightly oversized holes.

Installation of casing cooling channel includes:

- Manufacture of the cooling channel by bending and welding.
- Preparation of channel grooves and holes in the Straight Leg Outboard component.
- Welding of the cooling channel along the Straight Leg Outboard component.
-

4.8.1 Technical requirements

- The Contractor must form the tube according to the requirements reported in drawing 010301-503006 for ASG and drawing number 010301-503106 for Alstom. Bending must be carried out using equipment equipped with non-ferromagnetic rollers, to avoid contamination of the stainless steel of the tubes.
- Provisions must be taken in order to avoid squeezing or buckling of the pipe during bending. After bending the pipe must be thoroughly cleaned from any traces of inert material.
- The tube must be closed at both ends, by using welded plugs. Openings must be drilled on the side wall and the round termination pipe must be welded in place.
- The extension of the termination pipe must be sufficient to allow welding of the external cooling line after the final impregnation of the casing.
- The Straight Leg Outboard component must be machined in order to create the groove for the insertion of the cooling channel, and passing holes must be prepared where the termination pipes crosses the segment lateral plates.
- The cooling channel must be welded on the straight section of the Straight Leg Outboard component channel walls, up to the insertion in the grooves of the top/bottom curved parts of the Straight Leg Outboard component. The welds must ensure that no trapped volume is created between the casing and the pipe. The weld must be a continuous weld along the entire length of the tube.
- It must be demonstrated that there is no major blockage of the cooling channel. This could be done by endoscopic examination or pressure drop measurement. The Contractor shall agree the procedure with ENEA prior to the commencement of manufacturing.

4.8.2 Tooling Requirements

In order to satisfactorily install the cooling channels, the following is required:

- The bending tools must be equipped with non-ferromagnetic rollers, and no ferromagnetic part of any kind shall be in contact with the cooling tube at any time during the forming process.
- Appropriate supports and fixtures to be used during forming and storage.
- Appropriate clamping tools to be used during welding process.
- Appropriate welding tools.
- Non destructive weld testing equipment.
- Pressure testing equipment.

4.8.3 Welding

For the welding of the cooling channel the Contractor has to:

- Prepare detailed drawings of the assembly and of the parts to be welded including chamfers (if any);
- Define a pWPS, qualify the process (also drawing a WPQR) and finalize the WPS to be approved by ENEA

4.8.4 Acceptance Testing/Other Measurements

After welding of the cooling tube in the Straight Leg Outboard component, the following checks shall be carried out, under an independent THIRD PARTY INSPECTION AUTHORITY, to certify that activities are carried out in accordance with the agreed codes and standards:

- Leak test of the cooling channel. The leak rate at 2.5 MPa must be less than 10^{-8} Pa·m³ / s.
- Pressure test of each cooling channel using nitrogen or helium at 2.5 MPa, for one hour time.

The Supplier shall arrange free access for the inspector(s) to his works or at the works of his subcontractor's, so that the inspector(s) may carry out his duties as described. The Supplier shall provide the inspector(s) with copies of all relevant test reports and other facilities, as may be necessary, so that he is able to certify that deliverables meet the technical requirements.

5 Delivery Requirements

The casing components will be delivered as welded components prepared for winding pack insertion. The surfaces will be machined according to the geometry, the dimensions, the roughness and the tolerances defined in the drawings.

- To confirm that the fabrications are within specification, a series of acceptance tests are made during manufacture (see 6.5). A report detailing the results of the acceptance tests will be made available to the Contractor. The acceptance tests include:
 - Non destructive testing of all welds;
 - Conformity check on all material certificates;
 - For the ASG casing components, detailed measurement of key dimensions as shown in drawing numbers 010301-503001, 010301-503002, 010301-503003, 010301-503004, 010301-503005 and 010301-503006.
 - For Alstom, detailed measurement of key dimensions as shown in drawing numbers 010301-503101, 010301-503102, 010301-503103, 010301-503104, 010301-503105 and 010301-503106 for ASG.
- The components will be free from burrs and sharp edges.
- The components will be cleaned and free from oil or other debris.
- The components will be uniquely labelled
- The packaging is designed to ensure there are no permanent deformations in the structures during road transport. The packaging is designed to allow the components to be stored outside.

5.1 Packaging

The Contractor is responsible for the design and manufacture of the packaging for the casing components. As such, the Contractor shall submit a Detailed Procedure in accordance with the requirements of the Validation program, describing the complete proposed packaging arrangement. The Detailed Procedure shall consider the following key points:

- Each set of casing components must be packaged in a suitable fashion for road transport up to its specific coil manufacturing site (ASG SUPERCONDUCTORS Genova, Italia; ALSTOM Belfort, France) .
- Each set of casing components must be protected from moisture by usage of absorber bags and application of air-tight plastic wrap.
- The casing components shall be fitted with suitably located accelerometers to confirm that they have not undergone accelerations greater than 5 g during transport.
- The cooling channels must be sealed.

5.2 Destination

There are two manufacturers of the TF coil integration whose sites are in Italy and in France. In any case, the Contractor is the sole responsible for the delivery of each set of casing components to each of the two different coil manufacturing facilities.

6 Documentation

The Contractor is asked to supply a complete documentation related to all the aspect of the production process as well as a proper set of documents accompanying each set of Mock-ups and Casing Components delivered.

6.1 Quality plan and control plan

The Contractor shall supply a quality plan and a control plan basing on the requirements specified in the Management Specification.

6.2 Production Process description

The Contractor shall propose a complete Production Process description covering all the steps, from the acceptance of the raw material to the delivery of the TF Coil Casing Components. The Production Process description shall list all the various production phases and issue dedicated Detailed Procedures for those steps which are deemed by Contractor as “special processes”. The whole Production Process description, including the Detailed Procedures, shall be submitted to ENEA for approval prior to the commencement of the manufacturing process. Since ENEA relies on the experience of the Contractor to define the production process, the responsibility of product quality compliant with the Technical specification requests after following the procedure remains with the Contractor.

Basing on the approved Production Process Description, ENEA will define the preliminary Control Point list.

6.3 Validation program

It is expected that some parts of the manufacturing activities will include special processes (those for which a Detailed Procedure is required, see 6.1) that need to be validated prior to the production stage. The Validation Program shall include the list and the detailed description of such processes.

Validation could be carried out using any of the following means:

- Manufacture and testing of one or more partial mock-up which is representative of the final design geometry using the proposed manufacturing processes, or
- By review of similar manufacturing processes which have been carried out previously in the same facility, and have demonstrated success in a similar operating environment.

In any case, the Contractor shall provide suitable documentation to demonstrate confidence in the process.

The manufacturing of the mockups described in 3.2 could be part of the validation program as far as the building of the mock-up is based on the same processes that will be used to manufacture the Casing Components.

Being the welding a special process, it shall be surely included in the validation program. A preliminary Welding Procedure Specification shall be prepared by the Contractor for each welding to be performed in the manufacturing process. Each WPS shall include the details about the welding process, the geometry of the part to be joined and the preparation (by means of detailed drawings) and the relevant welding variables (arc current and voltage, consumables, backing/shielding, welding

position, number of run, position etc.). A WPQR shall be prepared at the end of the welding validation phase and be referenced by the WPS.

6.4 Validation Report for all the special process

The Validation of special processes should be documented issuing a Validation Report for each item foreseen in the Validation Program. Such Report shall include the description of the activities performed to demonstrate the effectiveness and the repeatability of the process, together with the results of the test carried out to confirm the fulfillment of the requirements. Hence, visual inspection, geometrical check, destructive test on mock-up, non destructive test, etc. should be part of the Validation report.

Validation shall be performed for all the welding process issuing the needed Welding Procedure Specification. The WPS must include all the information relevant to identify the welding process, to control the repeatability and to supply the instruction to the welding operators. The WPS shall be available for reference by welders or welding operators, the responsible welding engineer and the authorized Inspector.

The information included in the WPS must be compliant with the requirements of the reference standards. A Welding Procedure Qualification Report must support the WPS and shall contain the details about the method of qualification (mockup or similar process already qualified or standard welding procedure reference). The number and the type of Destructive and Non Destructive test must be at least compliant with the reference standard and furthermore integrated with the test required for the specific component as described in the relative paragraph in this document. WPS and WPQR together with the reports for the DT and NDT performed during qualification for all the welding foreseen shall be included by the Contractor in the Validation Report.

6.5 Acceptance Data Package

For each set of TF Coil Casing Components, an Acceptance Data Package shall be compiled. The requirements will be defined in detail by ENEA that will issue a report format after the approval of the quality documents. Basically the Acceptance Data Package will include at least:

- All certificates of successful passing of all the required quality checks or tests in all the production stages: raw material, unfinished parte stage, delivery and final test. These documents must include report from :
 - NDT;
 - Helium channel leak check;
 - chemical and material performance test (both for raw materials and for forged ingots and/or bent plates);
 - 3D measurements (e.g. laser tracking)
- Identification number for all the billet used to realize parts and or sub-assembly.
- Travellers with the evidence by signature of the executing person for each production phase.
- Details of any modifications made to the Detailed Procedure including a description of why the modifications were required (i.e. approved Deviation Request).

- Records detailing any design changes which have been agreed and incorporated in the actual manufacturing process (i.e. approved Deviation Request). Where design changes have been carried out, the following shall be included:
 - the technical details of the design change,
 - the implications of the design change on the manufacturing process, and
 - agreement reached with ENEA for the design change.
- Non conformity reports (if any) including the following details:
 - detail of the non conformity,
 - proposed resolution for the non conformity including supporting analysis,
 - agreement reached with ENEA and, where appropriate, F4E, for the resolution of the non conformity,
 - formal communication that the non conformity case has been solved.
- Drawings of the Component “as built” in case of non conformity that impact the dimensions, the geometry or the tolerances. Otherwise is intended that the components delivered perfectly fit the drawings.
- Results of all measurements carried out during manufacture.
- Material certificates for all raw materials, including welding materials, used during the manufacturing process.

All of the above documentation shall be included in the Acceptance Data Package for each set of TF Coil Casing Components set and must be delivered together with the components themselves. The documentation shall be complete and self consistent, containing also the records already supplied during the manufacturing phase.

	JT60SA-Management Specification for supply of 18 sets of Toroidal Field Coil Casing Components.	QMS-JT60CC-01	Rev. 0
		Pag 1 di 33	

TITLE	JT60SA-Management Specification for supply of 18 sets of Toroidal Field Coil Casing Components.
CLASSIFICATION: C	
 Association EURATOM-ENEA Agenzia nazionale per le nuove tecnologie, l'energia e lo sviluppo economico sostenibile	
<p>This document specifies the quality and management requirements:</p> <ul style="list-style-type: none"> • the Bidder shall comply when preparing its offer/proposal; • the Supplier shall comply within the course of the Contract. <p>The description of the Supplier quality management system shall be established in a dedicated QUALITY PLAN for managing ENEA work activities.</p> <p>This document is issued for the execution of the Agreement of Collaboration between Fusion for Energy, CEA and ENEA for the joint implementation of the procurement arrangement for the design and manufacture of the toroidal field magnet for the Satellite Tokamak Programme.</p>	

Rev. 0 of 10 October 2011

0	10/10/2011	Paolo Rossi	Luigi Di Pace	Antonio Cucchiario
Rev.	Date	Author	Reviewer	Approver

Table of Contents

1. PURPOSE.....	4
2. DELIVERY TIME SCHEDULE	5
3. Ownership and responsibilities	6
4. SCOPE OF THE SUPPLIER QUALITY PLAN	6
4.1. AT TENDER (OR PROPOSAL) LEVEL.....	7
4.2. AT CONTRACT LEVEL.....	7
5. RESPONSIBILITIES	8
5.1. ENEA RESPONSIBILITIES.....	8
5.2. SUPPLIER RESPONSIBILITIES	8
6. QUALITY PLAN REQUIREMENTS	9
6.1. OBJECTIVES AND DELIVERABLES OF THE CONTRACT.....	9
6.2. RESPONSIBILITIES REQUIREMENTS	9
6.3. CONTRACT MANAGEMENT	10
6.4. WORK BREAKDOWN STRUCTURE (WBS).....	11
6.5. CONTROL PLAN.....	11
6.6. TIME SCHEDULE MANAGEMENT	12
6.7. RESOURCE MANAGEMENT.....	15
6.7.1. Special Processes Qualification.....	15
6.7.2. Staff Qualification.....	15
6.7.3. Material resources.....	16
6.8. NON CONFORMITIES AND DEVIATIONS MANAGEMENT.....	16
6.8.1. Management of Deviations	16
6.8.2. Nonconformity Management	17
6.8.3. RECORDS Management.....	18
6.9. INFORMATION AND DOCUMENTATION MANAGEMENT.....	18
6.9.1. Drawing Control.....	19
6.10. SUBCONTRACTING MANAGEMENT.....	20
6.11. ASSESSMENT AND VALIDATION MANAGEMENT.....	20
6.11.1. Measuring and Test Equipment	21
6.12. ACCEPTANCE AND DELIVERY REQUIREMENTS	21

6.12.1. Supplier Review of the acceptance data packages and supplier release note	21
6.12.2. DELIVERY OF A COIL casing set.....	22
6.12.3. Acceptance OF A COIL casing set.....	22
6.13. CONTRACT RISK MANAGEMENT.....	22
6.14. HEALTH & SAFETY.....	22
6.15. CODES (REGULATORY DOCUMENTS) AND STANDARDS	22
7. QUALITY PLAN UP-DATE AND VALIDATION.....	23
8. INSPECTION AND Quality AUDIT VISITS.....	23
8.1. AUDITS AND SURVEILLANCE.....	23
8.2. ENEA OBSERVERS ACCESS	24
8.3. THIRD PARTY INSPECTION AUTHORITY.....	24
9. MANDATORY DOCUMENT FORMATS	24
9.1. ELECTRONIC DOCUMENTS	25
9.2. CONTROL PLAN FORM(WORK SCHEDULE).....	27
9.3. DEVIATION REQUEST	28
9.4. NONCONFORMITY REPORT.....	29
9.5. DOCUMENTATION SCHEDULE FORM.....	30
9.6. SUBCONTRACTING SCHEDULE FORM.....	31
9.7. SUPPLIER RELEASE NOTE	32

	JT60SA-Management Specification for supply of 18 sets of Toroidal Field Coil Casing Components.	QMS-JT60CC-01	Rev. 0
		Pag 3 di 33	

TERMS AND DEFINITIONS

Term	Definition	Acronym
Acceptance Data Package	Is the documentation package linked with a deliverable to be submitted by the supplier	ADP
Fusion for Energy	The European Joint Undertaking for ITER and the Development of Fusion Energy	F4E
ENEA Technical Responsible Officer	ENEA's responsible for communicating all technical contractual actions and decisions to the Supplier	TRO
IPR	Intellectual Property Rights	IPR
Supplier Technical Responsible Officer	Supplier's responsible for communicating all technical contractual actions and decisions to ENEA	
KOM	Kick-Off Meeting of the Contract	KOM
Subcontractor	All economic operators who supply items to the Supplier under the Contract	
WBS	Work Breakdown Structure	WBS
Supplier	The supplier is the Contractor as defined in the supply Contract. The successful Bidder (Tenderer or Applicant) is referred in the document as the "supplier". The supply-chain follows the scheme below Supplier -> Customer (ENEA)	
Bidder	The Bidder is the tenderer for the supply or service Contract (economic operator tendering for).	

REFERENCE DOCUMENTS

- [1] JT-60SA Integrated Project Team Common Quality Management System (CQMS)
- [2] EU-Quality Management System (EU-QMS)
- [3] ISO 9001 (2008)

	JT60SA-Management Specification for supply of 18 sets of Toroidal Field Coil Casing Components.	QMS-JT60CC-01	Rev. 0
		Pag 4 di 33	

1. PURPOSE

This document specifies the quality and management requirements that:

- the Bidder shall comply with when preparing its offer/proposal;
- the Supplier shall comply with during the course of the Contract.

The subject of this contract is the manufacture of the **18 sets of TF coil casing components, 2 sets of mock-up components**, works acceptance tests, packaging . The contract also includes the delivery of nine sets of TF coil casing components to ASG SUPERCONDUCTORS (Genova, Italia) and the other nine to ALSTOM (Belfort France) for the subsequent coil integration activities with the winding pack and for the final coil machining.

The associated technical specification defines the detailed technical requirements for the coil casing components manufacture, transport frame, packaging and associated documentation (acceptance data package). Additionally, technical information associated with delivery requirements for the components are provided.

The quality management system of the Supplier and their Subcontractors implemented to complete the work shall be compliant with the requirements defined in this document and in the technical specification.

The description of the Supplier quality management system shall be established in a dedicated **Quality Plan** for managing ENEA work activities. This Quality Plan shall:

- comply with the requirements defined in §6, and
- be in accordance with the JT-60SA CQMS [1].

2. DELIVERY TIME SCHEDULE

Considering that the contract signature date will be within week 20/2012, the mock-ups components and the eighteen packaged coil casing components sets with their associated transport frame and acceptance data package shall be delivered to ASG SUPERCONDUCTORS (9 sets) and ALSTOM (9 sets) according to the following time schedule:

✓ Mock-up components		50/2012
✓ Coil Casing Set (CS) 1 delivery	week/year	35/2013
✓ Coil CS 10 delivery		41/2013
✓ Coil CS 11 delivery		47/2013
✓ Coil CS 2 delivery		01/2014
✓ Coil CS 12 delivery		07/2014
✓ Coil CS 3 delivery		13/2014
✓ Coil CS 13 delivery		19/2014
✓ Coil CS 4 delivery		25/2014
✓ Coil CS 14 delivery		31/2014
✓ Coil CS 15 delivery		37/2014
✓ Coil CS 5 delivery		43/2014
✓ Coil CS 16 delivery		49/2014
✓ Coil CS 6 delivery		03/2015
✓ Coil CS 17 delivery		09/2015
✓ Coil CS 18 delivery		16/2015
✓ Coil CS 7 delivery		22/2015
✓ Coil CS 8 delivery		38/2015
✓ Coil CS 9 delivery		53/2015

	JT60SA-Management Specification for supply of 18 sets of Toroidal Field Coil Casing Components.	QMS-JT60CC-01	Rev. 0
		Pag 6 di 33	

3. OWNERSHIP AND RESPONSIBILITIES

After acceptance by ENEA of the provisional acceptance data package (ADP, quality documentation to be provided with each delivered coil for the works acceptance), the Supplier will be responsible for the transport of the coils to ALSTOM in France and ASG Superconductors in Italy. The acceptance data package will only be complete after completion of the transportation.

Upon delivery ENEA or its representative will sign a 'receipt note' (recognition of receipt only) if the deliverable is in the specified conditions, and the transport was performed as required.

The responsibility for the coil is then transferred to the organization in charge of the subsequent coil integration activities with the winding pack and for the final coil machining (ALSTOM and ASG SUPERCONDUCTORS).

ENEA will declare the deliverable conformity by issuing an 'Acceptance Note' if the coil casing components comply with the technical specification and contractual requirements. **The ownership of the coil is then transferred from the Supplier to ENEA, and contextually from ENEA to ALSTOM or ASG SUPERCONDUCTORS.**

ENEA signature of the Acceptance Note shall not relieve the Supplier from any contractual obligations and responsibilities.

4. SCOPE OF THE SUPPLIER QUALITY PLAN

The Quality Plan to be provided by the supplier shall describe the operational quality system implemented by the Supplier to ensure that:

- Contract requirements will be met, and
- Evidence of such compliance will be maintained.

The Quality Plan may be a single document that covers the whole scope of the Contract, including work performed by Subcontractors or it may be an assembly of separate well identified documents.

The structure of the Quality Plan should follow the structure of the section 6.

The Quality Plan shall encompass all activities performed in connection with the Contract.

The level of detail in the Quality Plan shall be consistent with:

- The technical requirements of the Contract;
- The complexity of the economic operators, functions and activities involved;
- The degree of design innovation;
- The involvement of innovative processes;
- The involvement special processes which cannot be fully verified by an inspection or test;
- The degree to which functional compliance can be demonstrated by inspection or test;

	JT60SA-Management Specification for supply of 18 sets of Toroidal Field Coil Casing Components.	QMS-JT60CC-01	Rev. 0
		Pag 7 di 33	

- Design, performance or manufacturing margins.

The compliance of the Quality Plan with this document shall replace any need for QA certification.

Nevertheless in presence of QA certification of the Supplier, the related documentation shall be provided.

4.1. AT TENDER (OR PROPOSAL) LEVEL

The Bidder shall provide, in its offer/proposal a meaningful outline of a preliminary dedicated **Quality Plan** where the plans, schedules and explanation of the provisions to comply with the following requirements will be assembled.

During offer/proposal, due to the nature of the process, the Bidder might not have all the information that they will have as a successful Bidder. As result of this limitation, at this stage the Quality Plan cannot be a “complete” version and is referenced as an “outline’ version where:

- Some sections will be addressed as a description of the proposed system.
- The remaining sections shall have the description of the Bidder’s current system.

4.2. AT CONTRACT LEVEL

After the Contract signature, the Quality Plan shall encompass the following sequential stages:

1. at the **kick-off meeting** the parties shall agree on the improvement of the **preliminary Quality Plan and on the particular provisions to include in it;**
2. 60 days after the kick-of-meeting the supplier shall issue the updated quality plan to ENEA for approval.
3. the Supplier shall **not begin any manufacturing or purchase activity without the Quality Plan being approved in writing by ENEA;**
4. during Contract implementation, the Supplier shall update the Quality Plan (or parts of it) as/ff required and shall submit it for approval to ENEA.

	JT60SA-Management Specification for supply of 18 sets of Toroidal Field Coil Casing Components.	QMS-JT60CC-01	Rev. 0
		Pag 8 di 33	

5. RESPONSIBILITIES

5.1. ENEA RESPONSIBILITIES

ENEA is responsible for:

- The preliminary design of the coil casing components, ensuring that this design meets the requirements imposed by the basic documentation of JT-60SA: Plant Integration Document, CQMS [1], EU-Quality Management System [2];
- Providing sufficient detailed specifications, CATIA models and drawings as input for the manufacturing of the casing components;
- Approval of the final specification for material procurement.
- Approval of the subcontractors selected by the Supplier.
- Review and approval of the documentation issued by the Supplier within the contract.
- Monitoring of the casing components through the monitoring meetings and reports established in section 6.3.
- Monitoring and control of the actions/items defined at the Hold Points, and witness of all tests performed during manufacturing phase as well as final acceptance tests.
- Informing Fusion for Energy of the date of the meetings, inspections, etc. for their possible attendance.
- Acceptance of the manufactured coil casing components, fully in compliance with QA and technical requirements.

Any additional casing component for test/qualification activities will be manufactured by the supplier at his own expense.

5.2. SUPPLIER RESPONSIBILITIES

The supplier responsibilities are defined in section 6.2.

	JT60SA-Management Specification for supply of 18 sets of Toroidal Field Coil Casing Components.	QMS-JT60CC-01	Rev. 0
		Pag 9 di 33	

6. QUALITY PLAN REQUIREMENTS

The following subsections specify the quality and management requirements for the Contract to be addressed in the Quality Plan. The quality plan to be provided by supplier shall have the structure of this section.

These elements are not limitative and could be complemented by the Supplier.

6.1. OBJECTIVES AND DELIVERABLES OF THE CONTRACT

In this section the Bidder shall describe how he understands the subject of the Contract. Options to be covered in the Bidder's offer/proposal are to be included in this description, and may remain in the Contract if appropriate.

The deliverables are defined as toroidal field coil casing components and associated documentation.

The Bidder shall issue a table including all items to be supplied, specifying:

- number and quantity;
- the level of subcontracting;
- all associated documents: Acceptance Data Package (ADP)

An acceptance data package shall be delivered with each completed coil casing set and at the end of the contract.

6.2. RESPONSIBILITIES REQUIREMENTS

The Supplier is responsible for the procurement of the material, manufacture, testing and delivery of the components, in accordance with this specification and the technical specification.

The Supplier is responsible for the following items among others:

- Implementation of a Quality Plan for the contract;
- Implementation of a risk management plan;
- Definition of the manufacturing route for the manufacturing of the coil components;
- Definition of the metrology systems for the coils components;
- Welding plan;
- Guarantee that its subcontractors comply with the QA requirements written in this specification.

This section shall indicate the name and contact details of:

- The Supplier Technical Responsible Officer in charge of the Contract
- The Supplier Quality Representative for the Contract.

The Supplier shall identify the different organizations involved to perform the Contract and detail the breakdown of responsibilities (an organizational flowchart should facilitate the understanding).

	JT60SA-Management Specification for supply of 18 sets of Toroidal Field Coil Casing Components.	QMS-JT60CC-01	Rev. 0
		Pag 10 di 33	

The Supplier Technical Responsible Officer shall coordinate planning, performance and control of the work, including work assigned to subcontractors. The Supplier Technical Responsible Officer shall keep time schedules and issue progress reports.

The Supplier Quality Representative shall be independent from the Supplier technical responsible officer. He shall ensure that the Quality Plan, quality procedures and detailed work instructions are followed during the course of the Contract in order to guarantee that all contractual quality requirements are met. The Supplier Quality Representative shall assess and control the quality management at the subcontractor's premises.

ENEA shall be informed of any change of Supplier Technical Responsible Officer or Quality Representative.

6.3. CONTRACT MANAGEMENT

The activities shall commence with an official **kick-off meeting** where the following items shall be discussed and agreed:

- Confirmation of the specifications, specific requirements and contractual input;
- The Supplier's Quality plan
- Documentation review lead time;
- Plans for implementations of the Contract;
- Detailed schedule of the contractual activities, including milestones;
- Frequency of Document Schedule and Control Plan review ;
- Contents of the ADP and Contract Final Report (if not agreed otherwise, drafts submission period is one month);
- Frequency and location of the proposed progress meetings;
- The supplier shall be responsible to issue the minutes of the meetings organized with ENEA;
- Management of Intellectual Property;

Unless agreed otherwise, the following shall be 'in person' meetings (and obligatory):

- kick-off meeting;
- final report meeting;
- progress meetings.

At the end of the Contract, after delivery of all items, the Supplier shall issue a **Final Report** of the Contract. The Final Report shall contain, but shall not necessarily be limited to, the following information:

- Summary of the Contract;
- Compilation of all Contract minutes and reports;
- Final Contract schedule;
- Final Contract Quality Plan;
- Final Control Plan
- All Contract ADP's (or reference to them);
- Final results summary incorporating the results of all tests and surveys carried out;

	JT60SA-Management Specification for supply of 18 sets of Toroidal Field Coil Casing Components.	QMS-JT60CC-01	Rev. 0
		Pag 11 di 33	

- Copies of all as-built drawings (and CAD models where applicable);
- Final foreground IPR declaration (Background declaration form, as supplied in the contract documentation);
- Full photographic record of the manufacture.

The progress report (frequency to be agreed with ENEA) shall be sent to ENEA making a status of:

- Work completed;
- Deviations proposed and Nonconformities raised with their acceptance status;
- Work scheduled.

The supplier shall organize progress meeting and shall be responsible to issue the minutes of these meetings.

6.4. WORK BREAKDOWN STRUCTURE (WBS)

The Supplier shall provide a detailed WBS of the activities to be performed in the course of the contract. The level of details must be commensurate in order to allow a proper control of these activities, including the process qualification activities, procurement activities and manufacturing and measurement activities. This WBS must describe how potentially subcontracted activities are linked with internal activities.

As part of the WBS the supplier shall issue an outline description of how they intend to manufacturing the coil casing components. In particular this shall include:

- ✓ The overall expected layout of the manufacturing line;
- ✓ Intended number of components per set, machining/welding/checks plan;
- ✓ Means by which the components shall be moved before and after manufacturing operation (machining, welding, inspection)

The main items of equipment required to make the casing components (e.g. crane, CCM machine,) shall be included where appropriate, as well as a statement of their current status (e.g. to be purchased, in regular use, to be modified).

6.5. CONTROL PLAN

In this section the Supplier shall provide a Control Plan describing sequences of the work (including process validation, quality controls), milestones, key points, reviews and a WBS along with a corresponding detailed schedule (see section 6.6). It shall include at least the following:

- Requirements originated from the design and manufacturing validation test program in the Technical Specification (qualification and validation requirements, needs for mock-up or prototypes...).
- All activities and tests to be performed in order to comply with the applicable laws/codes as specified in the Technical Specification.
- List of the required hold points, production readiness review, notification points and report points. The control points shall conform to the requirements of section 6.6.

For each particular operation, the Control Plan shall:

	JT60SA-Management Specification for supply of 18 sets of Toroidal Field Coil Casing Components.	QMS-JT60CC-01	Rev. 0
		Pag 12 di 33	

- Identify the requirements and instructions applicable to these operations,
- Identify the operations to be witnessed and those where notification is required,
- Provide for recording the verification and completion of these operations.

The level of detail in the Control Plan shall be such as:

- To prevent the inadvertent bypassing of critical operations,
- To enable adequate planning, monitoring and verification of the key activities.

It shall encompass the whole scope of the Contract from design to delivery including all work performed by subcontractors.

To ensure that operations are performed as directed in the Control Plan, the document shall be directly accessible to those carrying out the work.

The Control Plan shall be in English language.

ENEA acceptance of the Control Plan shall not relieve the Supplier of any contractual obligations and responsibilities.

An example of the Control Plan format is shown in §9.2. Any change in the content will be subject to ENEA approval prior to their use.

6.6. TIME SCHEDULE MANAGEMENT

In this section the Supplier shall describe its approach to control the time schedule, including use of software or templates to monitor the time schedule (these shall be compatible with the formats defined in §9.1).

The supplier shall establish a detailed time schedule of all the activities performed for the completion of the contract, including subcontracted activities. It shall present the overall strategy for design, purchasing, process/tooling qualification, mock-up completion, manufacture and delivery of the components. This time schedule shall include the various milestones, hold points etc. given in the table below.

On a monthly basis, the progress report shall include the

- ✓ status of the actual work schedule with respect to the agreed baseline;
- ✓ proposed corrective action to return to the baseline schedule in the event of any delay;
- ✓ proposed mitigation for any known risk to the schedule.

The supplier shall provide the precise process to report the time schedule evolution to ENEA.

Ref.	Del/MS description
SIG	18 sets of TF coil casing components contract awarded
MS 1	Kick-of-meeting
MS 2	Delivery of the updated quality plan including <ul style="list-style-type: none"> - Control plan - Documentation schedule - Subcontracting schedule - Risk management plan - Format of all the quality records
MS 3	Issue of the technical specification of the tooling and test equipment to be purchased
MS 4	Issue of the detailed procedure for: <ul style="list-style-type: none"> ✓ Material procurement ✓ Detail design of mock-up components (definition of the bevel details by ENEA 1 month before delivery) ✓ Composition of the coil casing components ✓ Construction of the components by welding ✓ Machining of the internal surfaces ✓ Weld grooves preparation ✓ Installation of cooling channel ✓ Associated tests measurements
MS 5	Issue of the qualification report for the critical processes <ul style="list-style-type: none"> ✓ Welding processes,
MS 6	Acceptance reports of the tooling and machines Delivery of the remaining detailed procedures needed to complete the work
MS 7	Definition the detailed design of the welds preparation by ENEA (3 months before the delivery of the first casing set).
MS 8	Delivery of manufacturing detailed design (2D drawings, 3D model and associated analyses)
MS 9	Production readiness review with external experts nominated by ENEA and Fusion for Energy before the start of the actual manufacturing activities
MS 10	Completion of the raw material procurement and relative acceptance test.
MS 11	Completion of the Composition of the first set coil casing components
MS 12	Completion of the construction of the first set of components by welding
MS 13	Completion of the machining of the internal surfaces of the first set
MS 14	Completion of the weld grooves preparation of the first set

Ref.	Del/MS description
MS15	Completion of installation of cooling channel in the first set
MS16	Associated tests measurements
MS 17	Release of the first coil casing set for delivery
Del 1	Mock-up components delivery to ASG and Alstom
Del 2	Coil CS 1 delivery to ASG
Del 3	Coil CS 10 delivery to ALSTOM
Del 4	Coil CS 11 delivery to ALSTOM
Del 5	Coil CS 2 delivery to ASG
Del 6	Coil CS 12 delivery to ALSTOM
Del 7	Coil CS 3 delivery to ASG
Del 8	Coil CS 13 delivery to ALSTOM
Del 9	Coil CS 4 delivery to ASG
Del 10	Coil CS 14 delivery to ALSTOM
Del 11	Coil CS 15 delivery to ALSTOM
Del 12	Coil CS 5 delivery to ASG
Del 13	Coil CS 16 delivery to ALSTOM
Del 14	Coil CS 6 delivery to ASG
Del 15	Coil CS 17 delivery to ALSTOM
Del 16	Coil CS 18 delivery to ALSTOM
Del 17	Coil CS 7 delivery to ASG
Del 18	Coil CS 8 delivery to ASG
Del 19	Coil CS 9 delivery to ASG

	JT60SA-Management Specification for supply of 18 sets of Toroidal Field Coil Casing Components.	QMS-JT60CC-01	Rev. 0
		Pag 15 di 33	

6.7. RESOURCE MANAGEMENT

In this section the Supplier shall provide a resources management system, detailing where applicable:

- The list of competences needed for each of the Contract stages with associated available supplier resources’;
- The number and type of personnel involved in each particular operation defined in the control plan;
- Specific experience and training for personnel;
- Specific qualifications for particular operations, in particular for the welding have to be compliant with the codes and standard required in the technical specification.

The Supplier shall provide proof that all workers are properly qualified.

6.7.1. SPECIAL PROCESSES QUALIFICATION

The Supplier and his Subcontractors shall be responsible for the manufacturing processes qualification tests when the qualification is required in the applicable codes and standards or is specified in other clauses of the Contract. In any such case, qualification tests shall be carried out before undertaking the corresponding processes. The Supplier shall submit the qualification records to ENEA for approval, along with the corresponding process execution procedures.

Processes qualification shall be included in the Control Plan. ENEA or its representatives will subject them to the same supervision requirements as to the rest of manufacture operations.

The provisions of this section shall also apply to the qualification of specific operators (welders, etc) for these processes when so required by the corresponding standards.

6.7.2. STAFF QUALIFICATION

In addition to the above, staff both from the Supplier and from his Subcontractors who participate in quality related activities shall be appropriately qualified. Staff qualification shall be done according to applicable standards for each case.

In addition to the qualifications needed for welders and staff in charge of acceptance tests, miscellaneous inspections, audits and non destructive examinations (NDE), the supplier shall implement an internal qualification program for the staff involved in the critical activities.

The supplier shall issue a training plan of the staff that will be involved in the performance and in the control of critical activities.

A file including the documentation of the Supplier’s staff and his subcontractors needing qualification shall be prepared. This file needs not to be submitted to ENEA but it must be kept by the Supplier or in his Subcontractor’s files with the rest of the documentation, for inspection and audit purposes.

Subcontracting of activities shall not exempt the Supplier from his responsibility to supervise and inspect those activities with qualified staff in accordance with the above two paragraphs.

	JT60SA-Management Specification for supply of 18 sets of Toroidal Field Coil Casing Components.	QMS-JT60CC-01	Rev. 0
		Pag 16 di 33	

6.7.3. MATERIAL RESOURCES

The supplier shall describe the machines (or process equipments) that will be used in the course of the contract. In particular, it shall indicate the age, maintenance status and the occupational rate of each machine. Status of the last use of the machine shall be indicated.

6.8. NON CONFORMITIES AND DEVIATIONS MANAGEMENT

A configuration management system shall be adopted to monitor the status of the work by the Supplier against the input provided by ENEA. Any divergence needs to be documented and approved by ENEA.

These divergences are addressed with the following processes:

- **Deviation** – a previously proposed and approved modification to a specified requirement (current approved configuration baselines).
- **Nonconformity** – any condition which does not comply with a specified requirement.

Specified requirements include:

- The technical or management specification requirements of the Contract,
- the requirements of any document issued in connection with the Contract and agreed with ENEA.

Each divergence process shall be represented in a process flowchart.

6.8.1. MANAGEMENT OF DEVIATIONS

This section shall describe the changes management system, which includes deviation processes initiated by the Supplier or its potential Subcontractors and those issued by ENEA or by a ENEA Customer.

This system shall ensure that:

- Deviation Requests are approved by ENEA before any implementation (through a Deviation Order);
- An ENEA Deviation Notice is followed by an ENEA Deviation Order before implementation;
- Status of the configuration and all associated deviations are made available to ENEA when requested.

'Deviation Request' originating from Supplier or subcontractors

When a modification to an approved configuration requirement is foreseen the Supplier shall discuss it with ENEA. If the proposal is considered beneficial, the Supplier shall request ENEA approval by issuing a Deviation Request (format in §9.3).

	JT60SA-Management Specification for supply of 18 sets of Toroidal Field Coil Casing Components.	QMS-JT60CC-01	Rev. 0
		Pag 17 di 33	

The deviation request shall contain or refer to all relevant material available to enable an informed decision to be taken. In particular, it shall include an assessment of the deviation consequences in terms of cost, delay and risk.

The deviation shall be implemented only after reception of a Deviation Order issued by ENEA.

'Deviation Request' originating from ENEA

The Supplier shall issue an impact assessment report for each deviation notice received from ENEA. The report should contain or refer to all relevant material available to enable an informed decision on the definite course of action to be taken. It should address the consequences of the deviation in terms of technical performance, cost, delay and risk. The deviation shall be implemented only after reception of a Deviation Order issued by ENEA.

6.8.2. NONCONFORMITY MANAGEMENT

The Nonconformity management system shall ensure that provisions are implemented in order to:

- Detect any nonconformity and segregate the non-conforming product
- Classify the nonconformity in two classes: major nonconformity and minor nonconformity
- Communicate to ENEA the list of all the nonconformities and the associated actions on a regular basis (if not agreed otherwise, at least once a month).
- Ensure that the appropriate Corrective Actions are implemented to prevent repetition of nonconformity
- Ensure that the appropriate process improvements (Preventive Actions) brought about by the Corrective Actions are implemented to prevent future nonconformities
- Ensure that nonconformity is raised by means of a nonconformity report, in case ENEA or their appointed representatives issue a nonconformity notice after detection of a relevant discrepancy.

Major nonconformity: divergence with impact on a requirement specified in the technical specification or in the management specification.

- The 'Nonconformity Report' shall be sent to ENEA with proposed Remedial Actions.
- Remedial Actions shall be implemented only after ENEA written acceptance.

Minor nonconformity: divergence with no impact on a requirement specified in the technical specification or in the management specification.

- The Supplier can take Remedial Actions to resolve the nonconformity within its own quality system.
- The 'Nonconformity Report' shall be sent to ENEA for information and the Remedial Action implemented.

The Supplier shall indicate **how, when and by whom** nonconformities will be processed including those originating from its Subcontractors.

	JT60SA-Management Specification for supply of 18 sets of Toroidal Field Coil Casing Components.	QMS-JT60CC-01	Rev. 0
		Pag 18 di 33	

6.8.3. RECORDS MANAGEMENT

Proposed formats for the “Nonconformity Report”, and “Deviation Request” are shown in §9.

The Supplier shall:

- sequentially number the Deviation Requests and Nonconformity Reports issued for each particular Contract;
- Maintain an electronic register of all Deviation Notices, Deviation Orders, Deviation Requests and Nonconformity Reports issued in respect of this Contract that must contain an indication of their distribution and acceptance status;

Nonconformity Reports, Deviation Requests, Deviation Orders and deviation consequences assessment reports are an integral part of the Contract. On or before the end of the Contract, all Nonconformity Reports, Deviation Requests, Deviation Orders, associated reports, and any relevant documentary evidence, must be included in an appendix to the Final Report handed over to ENEA.

The Supplier shall ensure that its Subcontractors implement the same procedure to control deviations and non conformities.

ENEA acceptance of Nonconformity Reports, Deviation Request:

- Is limited to the particular Contract and item referred to in the Request or in the Report
- Does not relieve the Supplier of any contractual obligations and responsibilities.

6.9. INFORMATION AND DOCUMENTATION MANAGEMENT

All quality and technical official documentation and information exchange between ENEA and the Supplier shall be through the ENEA’s TRO in charge of the Contract and the Supplier Technical Responsible Officer.

All documentation relevant to the Contract will have to be stored in the F4E electronic document management system (if not agreed otherwise). This includes, but is not necessarily limited to:

- Quality plans and associated documents (Control plans, documentation schedule...)
- Time Schedule
- Risk management plan
- Procedures
- Quality controls records

Minutes of the meetings

- Supporting analysis for deviation requests and Non conformances reports
- Progress reports
- Records of process and design qualification
- Engineering analysis

	JT60SA-Management Specification for supply of 18 sets of Toroidal Field Coil Casing Components.	QMS-JT60CC-01	Rev. 0
		Pag 19 di 33	

Documents associated to reviews

- Acceptance data package
- Configuration models and associated drawings

In this section the Supplier shall describe its documentation management system (SUP DMS). The documentation management system shall ensure that all the data received by the Supplier is properly recorded and managed and that only sound data will be provided to ENEA. As part of the SUP DMS, the supplier shall provide a Documentation Schedule (an example of format for the "Documentation Schedule" is shown in §9.5), detailing all documents and records relevant to the implementation of the Contract, including work performed by subcontractors. In particular the documentation Schedule shall establish the Acceptance data packages (ADP) that lists all the documents that are due with each set of casing components deliverable and shall list the foreseen documents that will be loaded into the F4E Document Management System.

The Documentation Schedule is a continually updated document and shall contain the main documents related to the deliverables.

Work shall not start until the relevant Documentation Schedule has been accepted by ENEA. During the contract phase the Documentation Schedule will be the reference for the document management within the contract.

All documents referenced in the Reports shall be made available together with the Reports in electronic format.

The Supplier shall keep all necessary documents and technical information related to the Contract and subcontract(s) for monitoring, quality assurance controls, checks and audits. If so required by ENEA, the Supplier shall provide copies of such documents for use by ENEA.

The Supplier shall keep the documents up to ten (10) years (or the regulatory period of time, whichever is longer) after the payment of the final balance of the Contract price or if so requested by ENEA, the Supplier shall transfer the requested documents to ENEA upon termination of the Contract.

ENEA acceptance of Documentation Schedule or approval of technical documents such as drawings sketches, specifications shall not relieve the Supplier of his responsibility of proper performance of the Contract.

The supplier shall define the format of all the quality records needed to control the design and manufacture (design control, traveller, NC reports...)

6.9.1. DRAWING CONTROL

For deliverables or ADP that include CAD data, the Supplier shall implement a drawing control system for any drawing activities.

The preparation, review, and approval of drawings are accomplished through controlled procedures that establish the approval authorities and responsibilities.

	JT60SA-Management Specification for supply of 18 sets of Toroidal Field Coil Casing Components.	QMS-JT60CC-01	Rev. 0
		Pag 20 di 33	

A design change, to modify an approved configuration baseline, is a “change” and shall be controlled according to §6.8. Alteration to drawings, without addressing configuration requirements, are defined as “Drawing Modifications” - modifications inherent to the different stages of the drawing process (e.g. “as defined”, “as detailed” and “as built” stages).

6.10. SUBCONTRACTING MANAGEMENT

The supplier shall issue a detailed procedure explaining how the requirements of the subcontracted items are defined and controlled. The procedure shall also describe how the requirements will be included in the contracting documents. The supplier shall implement an Acceptance procedure to ensure that the purchased goods and services are compliant with the contractual requirements. For each receipt of goods either delivered by ENEA or purchased by the supplier, the latter shall issue a receipt note recording the unique reference of the components or a reference of the batch with the date of delivery and agreement by the supplier quality representative that the delivered goods is compliant with the requirements (including documents to be delivered).

The Supplier shall ensure that each of his Subcontractors have a Quality System compliant to this specification; an assessment report shall be issued per Subcontractor.

Failing this, the Supplier shall undertake all the necessary actions to establish and maintain the Quality in the subcontractor’s premises in conformity with the present document and the technical specification.

The Supplier shall provide a “Subcontracting Schedule” (an example of the format is shown in §9.6), detailing:

- **All major or critical items and activities subcontracted** by the Supplier
- Item/Activity associated specification
- Relevant subcontractor Identification (including contact person)
- Proof of subcontractor qualification (e.g. ISO 9000 certification, assessment report)
- ENEA approval of the proposed Subcontractors

Subcontracting shall not start until the relevant Subcontracting Schedule has been accepted by ENEA.

The Subcontracting Schedule shall be updated as necessary, and the updated schedule shall be subjected to the same acceptance procedure as the original Subcontracting Schedule.

Purchased or subcontracted items or services shall be supplied together with their certificate of conformity to the specified requirements.

ENEA acceptance of the Subcontracting Schedule shall not relieve the Supplier of any contractual obligations and responsibilities.

6.11. ASSESSMENT AND VALIDATION MANAGEMENT

The supplier shall demonstrate how compliance with the Control Plan (§6.5) shall be controlled and recorded throughout the Contract. This includes the following subjects:

	JT60SA-Management Specification for supply of 18 sets of Toroidal Field Coil Casing Components.	QMS-JT60CC-01	Rev. 0
		Pag 21 di 33	

- Issue, signature and dating of records for each completed operation (so-called “travellers” and defined in the technical specification) to assure ENEA that all operations foreseen in the control plan have been properly performed and controlled;
- Identification and record of each report generated during the performance of any particular operation (e.g. test report and Nonconformity Report) and, where possible, identifying improvement opportunities;
- Access to the Supplier premises, Supplier personnel and Supplier completed work activities for third party audit or inspection (see §8).

6.11.1. MEASURING AND TEST EQUIPMENT

Measuring and test equipment shall be controlled showing evidence of:

- Equipment identification and calibration status
- Proper use (range, precision, ...) and proper output data format
- Record of proper calibration

Test records shall clearly identify any test equipment that has been used and its calibration status.

6.12. ACCEPTANCE AND DELIVERY REQUIREMENTS

The Supplier shall indicate how, when and by whom acceptance and delivery will be controlled.

6.12.1. SUPPLIER REVIEW OF THE ACCEPTANCE DATA PACKAGES AND SUPPLIER RELEASE

NOTE

Prior to deliveries, the Supplier should organize a deliverables-status acceptance review in accordance with the Contract requirements. This includes at least:

- Review of the documentation (ADP) to be provided (in accordance with the Documentation Schedule);
- Achievement of the technical requirements or performance test reports;
- Special processes and personnel qualification proof review,
- Review of the records and justification of all changes and derogations (nonconformity report, deviation request, deviation proposal and deviation order);
- Configuration status.
- Information about the management of Intellectual Property.
- This review is formalized with a formal supplier ‘Release Note’ signed by the Supplier Technical Responsible Officer in charge of the Contract and included in the ADP.

	JT60SA-Management Specification for supply of 18 sets of Toroidal Field Coil Casing Components.	QMS-JT60CC-01	Rev. 0
		Pag 22 di 33	

The ADP, including the release note, will be stored in the F4E Document management system. After the review of the ADP, the ENEA Responsible officer will give his written approval for the deliverable despatch.

6.12.2. DELIVERY OF A COIL CASING SET

Upon delivery ENEA or its representative will sign a 'receipt note' (recognition of reception only) if:

- the deliverable is in the specified conditions
- the Acceptance data package is completed

6.12.3. ACCEPTANCE OF A COIL CASING SET

After the successful passing of the acceptance tests, ENEA will declare the deliverable conformity by issuing an 'Acceptance Note'.

ENEA signature of the Acceptance Note shall not relieve the Supplier from any contractual obligations and responsibilities.

The Supplier shall ensure that its Subcontractors implement the same procedure to control acceptance and delivery.

The Contractor is responsible for any repair when the failure is directly attributable to the Contractor's manufacturing process(es).

6.13. CONTRACT RISK MANAGEMENT

The Supplier shall describe the provisions implemented in order to reduce the Contract exposure to risks regarding the expected performance and time schedule. This includes at least the following subjects:

- Preliminary risk analysis and assessment report in terms of expected performances and time schedule;
- Associated list of actions to implement in order to reduce the risk exposure of the project;
- Plan to upgrade the two previous documents.

6.14. HEALTH & SAFETY

In this section the Supplier shall demonstrate that he fulfils the health and safety regulations of the country where the activities will be developed.

6.15. CODES (REGULATORY DOCUMENTS) AND STANDARDS

The Quality Plan shall reference quality and management applicable codes, standards and regulatory requirements.

	JT60SA-Management Specification for supply of 18 sets of Toroidal Field Coil Casing Components.	QMS-JT60CC-01	Rev. 0
		Pag 23 di 33	

7. QUALITY PLAN UP-DATE AND VALIDATION

The Supplier shall up-date the Quality Plan after the kick-off meeting of the Contract. Written ENEA approval of the updated Quality Plan is needed before the beginning of the implementation.

The Supplier shall up-date the Quality Plan (or parts of it) each time it is needed. These up-dates shall have to be approved in writing by ENEA prior to their implementation.

The Quality Plan is an integral part of the Contract. Upon completion of the contract, the Quality Plan shall be included in the acceptance data package handed over to ENEA.

8. INSPECTION AND QUALITY AUDIT VISITS

The Supplier shall provide ENEA and F4E with access to documentation, premises and personnel (including that of his subcontractor's) during all stages of the Contract for the purpose of audit, review, surveillance and inspection.

ENEA and F4E reserve the right to make unscheduled visits to the Supplier's or Subcontractor's works and free access shall be provided at all reasonable times.

ENEA shall have the right to have permanent inspectors working on the Contract inside the Supplier's workshops. Should this be required, the Supplier shall reserve an office inside his workshops, equipped with a telephone and telefax with international access and internet access.

ENEA and F4E could require photographs and record video of anything connected to the pertaining contract (the obtained material shall remain confidential).

ENEA and F4E commit themselves to keep confidential any other information not linked to the contract that they might have access to during audits and surveillances to the Supplier's or Subcontractor's works.

8.1. AUDITS AND SURVEILLANCE

Planned and documented audits, reviews, surveillance and inspection of the Supplier's Quality Assurance arrangements may be carried out by ENEA or their appointed representatives to verify compliance with all quality and technical aspects of the Contract.

These activities may be extended to the Supplier's subcontractors. Regarding any deficiencies found, the Supplier shall implement or ensure that the subcontractors implement corrective actions in accordance with an agreed time-scale.

ENEA shall be informed of the Supplier's audits, reviews, surveillance and inspection activities, including those involving subcontractors. Notifications shall be in writing, preferably via fax or email.

Should on-site inspection services exist, the notification shall be sent directly to them well in advance. In this case, only ENEA shall be notified in writing of the points identified as hold points within the timeframe stipulated in the above paragraph.

	JT60SA-Management Specification for supply of 18 sets of Toroidal Field Coil Casing Components.	QMS-JT60CC-01	Rev. 0
		Pag 24 di 33	

The Supplier shall be responsible for all expenses derived from ENEA sending his own inspectors or representatives as a result of wrong notifications. When ENEA could not witness the activity ENEA may request the Supplier to repeat the activities considered as advice or hold points at his own expense. ENEA shall be responsible for all expense derived from the temporality stopped of the activity.

8.2. ENEA OBSERVERS ACCESS

ENE A shall have the right to be accompanied by observers to the agreed for surveillance and audits visits.

These observers will be identified in advance and agreed with the Supplier and will belong to one of the following entities:

- ENEA,
- Next user of the deliverable
- F4E

All the observers shall be bound by appropriate confidentiality obligations to be agreed in advance.

8.3. THIRD PARTY INSPECTION AUTHORITY

ENE A may, for the purpose of this Contract, appoint an independent inspection authority to certify that activities are carried out in accordance with the agreed codes and standards.

The Supplier shall arrange free access for the inspector(s) to his works or at the works of his subcontractor's, so that the inspector(s) may carry out his duties as described. The Supplier shall provide the inspector(s) with copies of all relevant test reports and other facilities, as may be necessary, so that he is able to certify that deliverables meet the technical requirements.

9. MANDATORY DOCUMENT FORMATS

All communications and official documentation shall be in the standard project language:

- For Monolingual Documentation, the language shall be English

For Dual-language Documentation, (regulatory or safety documentation requirements):

- The original and reference text shall be in English and all interpretations of it will be based on the English text. In the event of a conflict between different translations, the English text will prevail.
- The layout to be used is a dual-column page, where both versions of the document are in parallel, with English in the left column.

9.1. ELECTRONIC DOCUMENTS

Only the following electronic document file formats are acceptable for project documentation exchange and delivery. All documents must be supplied at all stages of the contract in all of the formats shown below (table 9_1).

In the event of additional formats being utilised, for example for specialised engineering calculations, fully useable data input and output files shall be provided (in English language, if available as standard inside the program).

Document Type	Editable		Reference	Informative
	Format	Version	Format	Format
Text Document	doc / rtf	MS Word v.97	pdf	—
Spreadsheet	xls	MS Excel v.97	pdf	—
CAD models and drawings	Cat	CATIA V5	cat	pdf of typical 3-D views
CAD drawings	Cat	CATIA V5	pdf	—
Schedules, Plans	mpp	MS Project	pdf	pdf of all pages
Scans and pictures	jpg	—	pdf	—
Movie	avi	—	avi	—
Presentations	.ppt	MS PowerPoint	pdf	—
Document Sets	.zip	—	—	—
Issued documents	—	—	pdf	—
Finite Element Calculations	ANSYS	—	ANSYS	pdf of typical 3-D views
“Document Schedule”	xls	MS Excel v.97	pdf	—
“Control Plan”	xls	MS Excel v.97	pdf	—

Table 9_1 – Mandatory document formats

Where the version is given, this indicates the lower version compatibility requirement.

Where editable versions exist (text documents, spreadsheets, drawings, etc) editable versions of the deliverables shall be provided in the ADP.

Alternative formats may be specified at the kick-off meeting, with the approval of ENEA at the sole expense and care of the Supplier.

To avoid an unnecessarily large numbers of files and assist in information location, documents which belong naturally to a set shall be agglomerated into one zipped electronic file, which shall contain an additional file with title page which describes the numbered and identified contents of the zip file and its version history. This zip file may also contain sub-directories and its contents may be changed as versions are updated. In Table 9_2 shows a list of suitable sets of documents, which shall be expanded at the KOM.

	JT60SA-Management Specification for supply of 18 sets of Toroidal Field Coil Casing Components.	QMS-JT60CC-01	Rev. 0
		Pag 26 di 33	

Description of Set	Included in Set
Progress Meeting	Agenda, Minutes, Action List and Presentations for one meeting
Photographs	Set taken at the same time or of a progression of the same item over time
Contract Specification	All Annexes and Appendices
Subject Grouping for analysis	All documents related to a particular analysis
Material Certificates	For all of a type of material, such as “60 mm thick SS plate”
Test Reports	For all of a type of test, such as “additional inspections for 60 mm thick SS plate”

Table 9_2 – Suitable sets of documents

A list of files describing the current status of the Contract documentation shall be maintained in spreadsheet format.

9.3. DEVIATION REQUEST

DEVIATION REQUEST

Section 1 – to be completed by the Supplier

	CP Number:		Issue Number:	Sheet:	of
1.	ENEA reference:		ENEA Customer ref:		
2.	Contract ID Ref.:		DMS #:		
3.	Supplier:				
4.	Item:				
5. ORIGINAL REQUIREMENT:					
[always mention the reference document (title, number, version) where the requirement comes]					
6. DEVIATION PROPOSAL :					
7. JUSTIFICATION:					
8. LIST OF ATTACHMENTS:					
9. IMPACT ANALYSIS:					
9.1	OTHER ITEMS	<input type="checkbox"/> NO	<input type="checkbox"/> YES	Report:	<input style="width: 100%;" type="text"/>
9.2	SCHEDULE	<input type="checkbox"/> NO	<input type="checkbox"/> YES	Report:	<input style="width: 100%;" type="text"/>
9.3	PERFORMANCE & COST	<input type="checkbox"/> NO	<input type="checkbox"/> YES	Report:	<input style="width: 100%;" type="text"/>
9.4	OTHER: <input style="width: 100px;" type="text"/>	<input type="checkbox"/> NO	<input type="checkbox"/> YES	Report:	<input style="width: 100%;" type="text"/>
Supplier's Technical Responsible			Supplier's Quality Representative		
<i>Name</i>	<i>Signature</i>	<i>Date</i>	<i>Name</i>	<i>Signature</i>	<i>Date</i>

[ELECTRONIC TEMPLATE WILL BE MADE AVAILABLE TO THE SUPPLIER]

9.4. NONCONFORMITY REPORT

NONCONFORMITY REPORT

Section 1 – to be completed by the Supplier

NCR Number:		Issue Number:	Sheet:	of	
1. ENEA reference:		ENEA Customer ref.:			
2. Contract ID Ref.:		DMS #:			
3. Supplier:					
4. Item:					
5. REQUIREMENT:					
6. DESCRIPTION OF NONCONFORMITY:					
7. PROPOSED REMEDIAL ACTION:					
<input type="checkbox"/> use as is <input type="checkbox"/> rework <input type="checkbox"/> repair <input type="checkbox"/> reject					
8. LIST OF ATTACHMENTS:					
9. PROPOSED NONCONFORMITY CATEGORY:					
<input type="checkbox"/> MINOR NONCONFORMITY (Report to be sent to ENEA for information and remedial action implemented)					
<input type="checkbox"/> MAJOR NONCONFORMITY (Remedial action implemented only after ENEA written acceptance)					
10. CORRECTIVE / PREVENTIVE ACTION:					
Supplier's Technical Responsible			Supplier's Quality Representative		
Name	Signature	Date	Name	Signature	Date

Section 2 – to be completed by ENEA

ENEA Technical Responsible Officer			ENEA QA Representative		
1. DECISION:			2. COMMENTS:		
Name	Signature	Date	Name	Signature	Date

[ELECTRONIC TEMPLATE WILL BE MADE AVAILABLE TO THE SUPPLIER]

9.5. DOCUMENTATION SCHEDULE FORM

DOCUMENTATION SCHEDULE

Doc. Number:		Issue Number:		Sheet:		of	
ENEA reference:		ENEA Customer ref:					
Supplier:		DMS #:					
Contract ID Ref.:		Item:					

Supplier		ENEA	Notes & acronyms
Prepared by:	Approved by	Acceptance	Field: distributed for review to the fields of expertise Distribution: A-Approved, I-Information, N-Non Distributed Status: R-Received, W-Waiting, A-Accepted, R-Rejected,
<i>Name, Sign & Date</i>	<i>Name, Sign & Date</i>	<i>Name, Sign & Date</i>	

Document/ Record ID	Rev.	Title	Responsible for Prep App. Dist.	Field	Date / Expected	Distribute d ENEA	Archiv e	Lan g	Stat us
------------------------	------	-------	------------------------------------	-------	--------------------	----------------------	-------------	----------	------------

[Up-to-date list of documents/ records/ drawings/ models/ plans/ schedules/ manuals/ data expected during the contract and/or essential to perform the task and/or part of the ADP]

[ELECTRONIC TEMPLATE WILL BE MADE AVAILABLE TO THE SUPPLIER]

9.7. SUPPLIER RELEASE NOTE

SUPPLIER RELEASE NOTE

Section 1 – to be completed by the Supplier

Note Number:		Issue Number:	Sheet:	of	
1. ENEA reference:		ENEA Customer ref:			
2. Contract ID Ref.:		DMS#:			
3. Supplier:					

Section 2 – Conformity statement to be completed by the Supplier

1. With the exception of the discrepancies listed below (section 2.6), we certify that the following equipment/service: (describe)					
2. Has been manufactured/performed, inspected and tested in accordance with the requirements described in the following documents: (documents list)					
3. That the equipment/service is complete.					
4. That all relevant verifications, inspections and tests are complete and satisfactory.					
5. That the following documents are those required by the Contract: (detailed list)					
6. List of any change proposal, deviation request and nonconformity report: (attached)					
Supplier's Technical Responsible			Supplier's Quality Representative		
Name	Signature	Date	Name	Signature	Date

Section 3 – to be completed by ENEA

ENEA Technical Responsible Officer			ENEA QA Representative		
1. DECISION:			2. COMMENTS:		
Name	Signature	Date	Name	Signature	Date

[ELECTRONIC TEMPLATE WILL BE MADE AVAILABLE TO THE SUPPLIER]

DIMENSIONS RELATE TO ROOM TEMPERATURE (293K)

-the closure shown has only an indicative purpose, the final design of the bevel will be forwarded by ENEA on the base of the specification of the coil suppliers

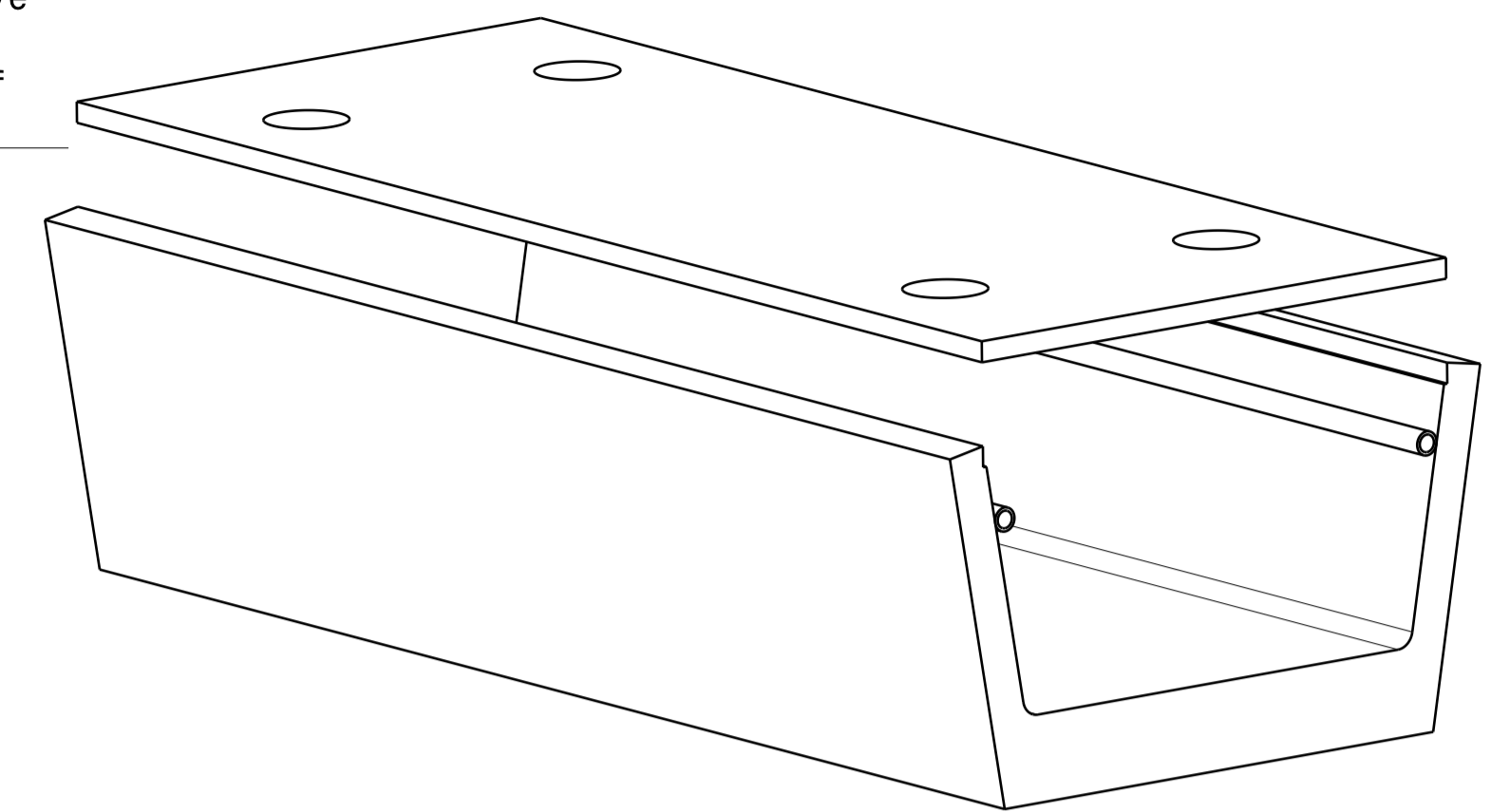
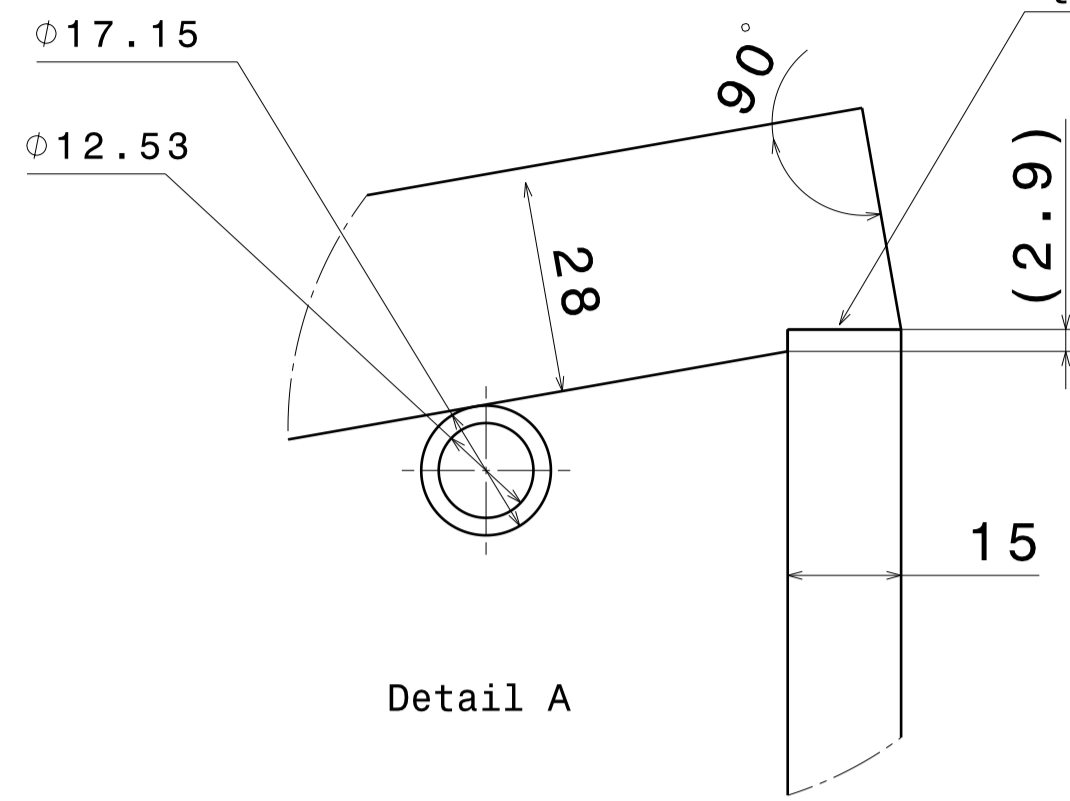

Isometric view
Scale: 1:5

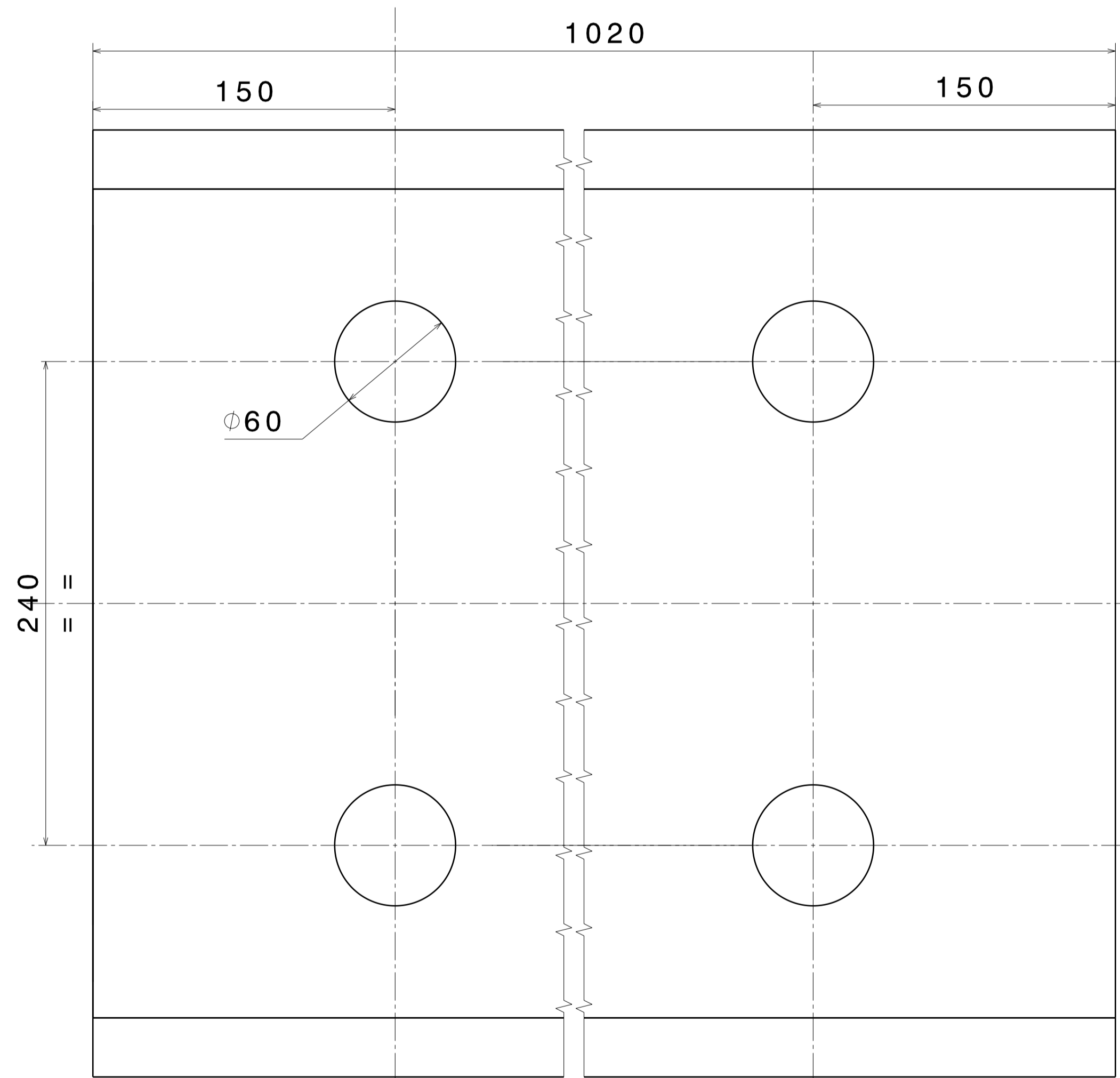

Right view
Scale: 1:2

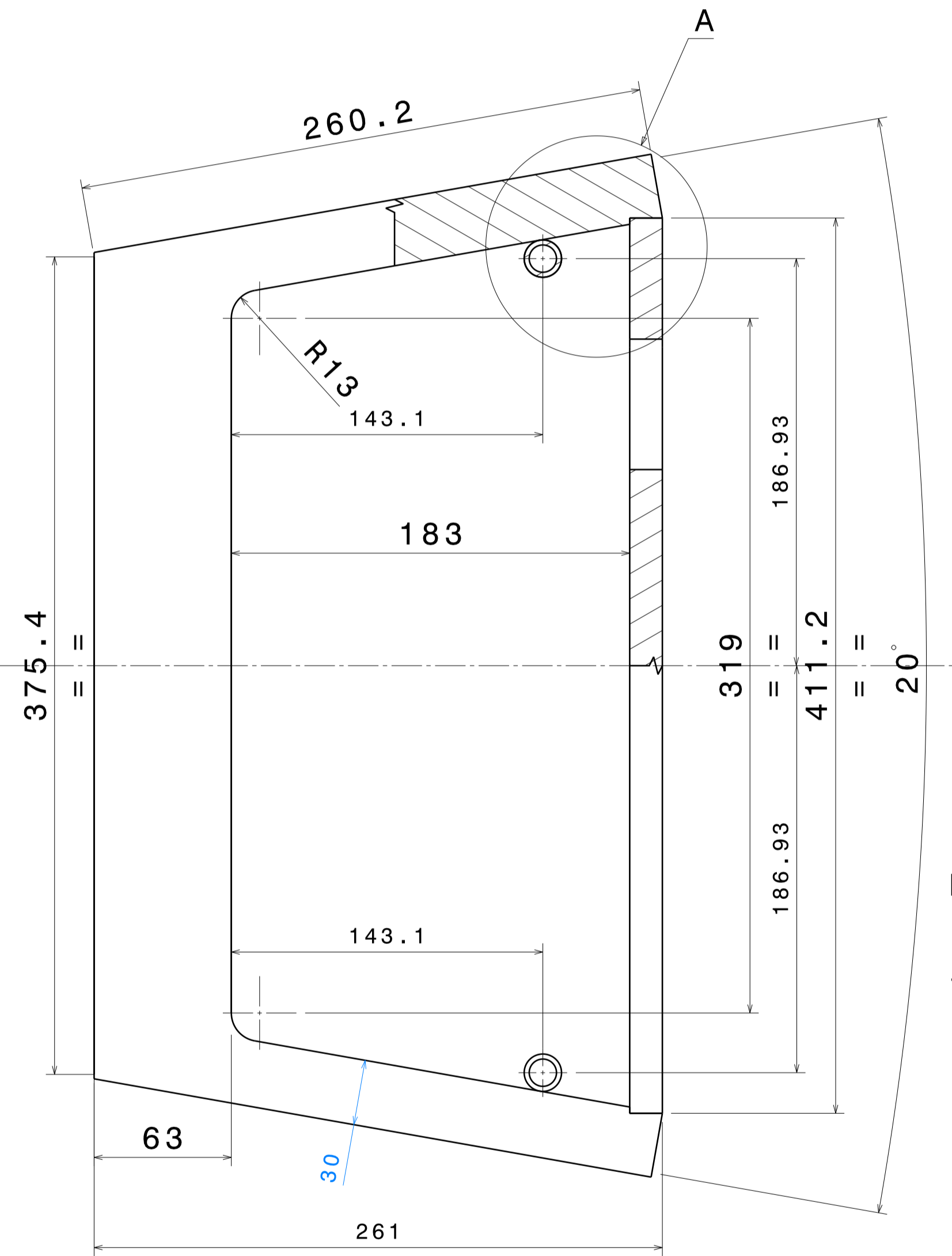

Front view
Scale: 1:2

NOTE:

- DIN ISO 2768-1 & 2768-2 general medium tolerance class for all machining unless otherwise specified
- APPLY ROUGHNESS Ra 3.2 UNLESS OTHERWISE SPECIFIED
- UPDATED FOR AGREEMENT WITH DRAWING N°: DD-JT60TF-ASG-13403

DRAWING FOR ASG-SUPERCONDUCTOR

FOR CONTRACT				Ref to 3D CatProduct: 010301 203007			
<small>CONFIDENTIAL UNLESS AUTHORISED</small> The information on this drawing is confidential under the terms of the BA agreement. This information shall not be transmitted to anyone who is not authorised to receive it.		APPROVED BY A. CUCCHIARO		Fusion Italy-Frascati Research Centre		CUSTOMER: Fusion-for-Energy	
REV DATE 28-05-2012		CHECKED BY		DRAWING TITLE MOCK UP: STRAIGHT BEAM 1 METRE LONG OF THE CASING (LONGITUDINAL WELDING)			
FIRST ISSUE DATE 27/07/2011		SCALE NTS		CONTROLLED BY G.M. POLLI		CODE ENEA ID: DD-JT60TF-NCO	
DRAWN BY G. BROLATTI		SHEET SIZE A1		FIRST ANGLE PROJECTION		WBS LEVELS 3 LEVELS	
010301		Drawing Number 503007		SHEET 01		REVISION 03	
				Maturity			

DIMENSIONS RELATE TO ROOM TEMPERATURE (293K)

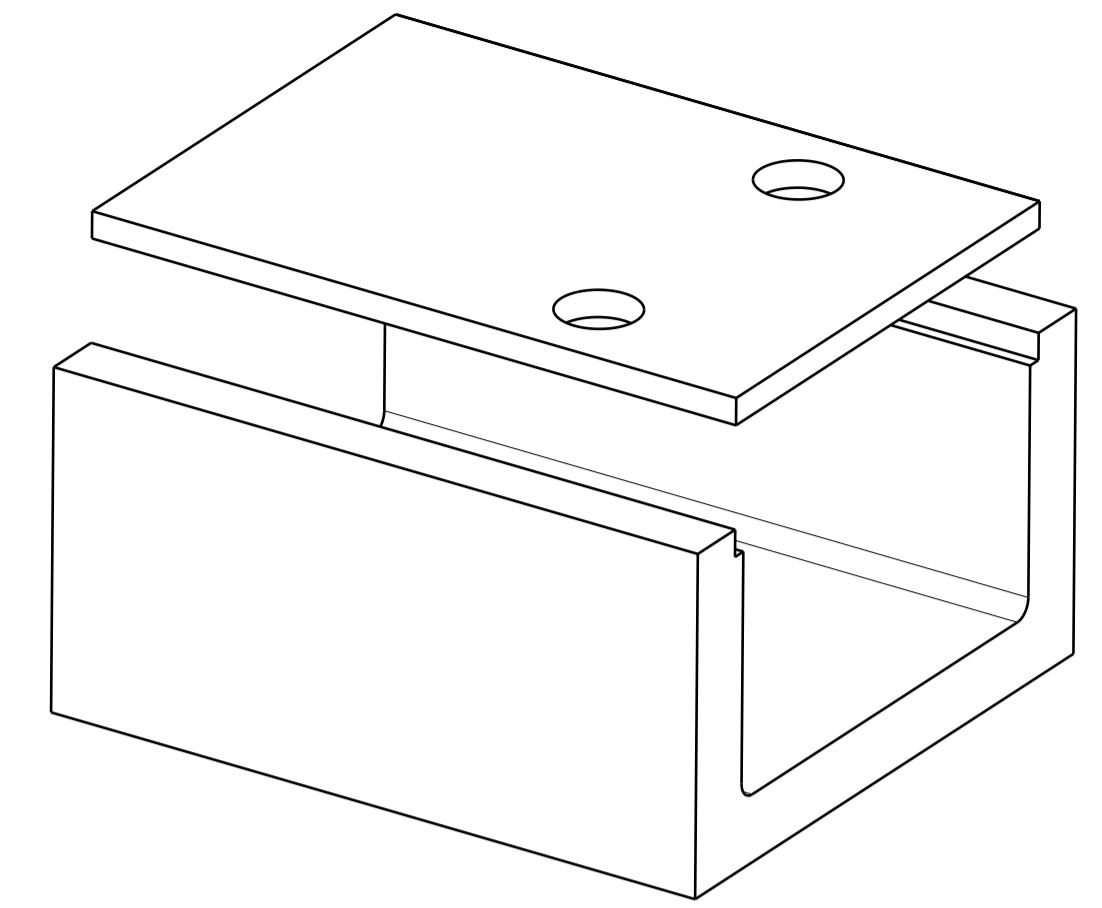

Isometric view

-the closure shown has only an indicative purpose, the final design of the bevel will be forwarded by ENEA on the base of the specification of the coil suppliers

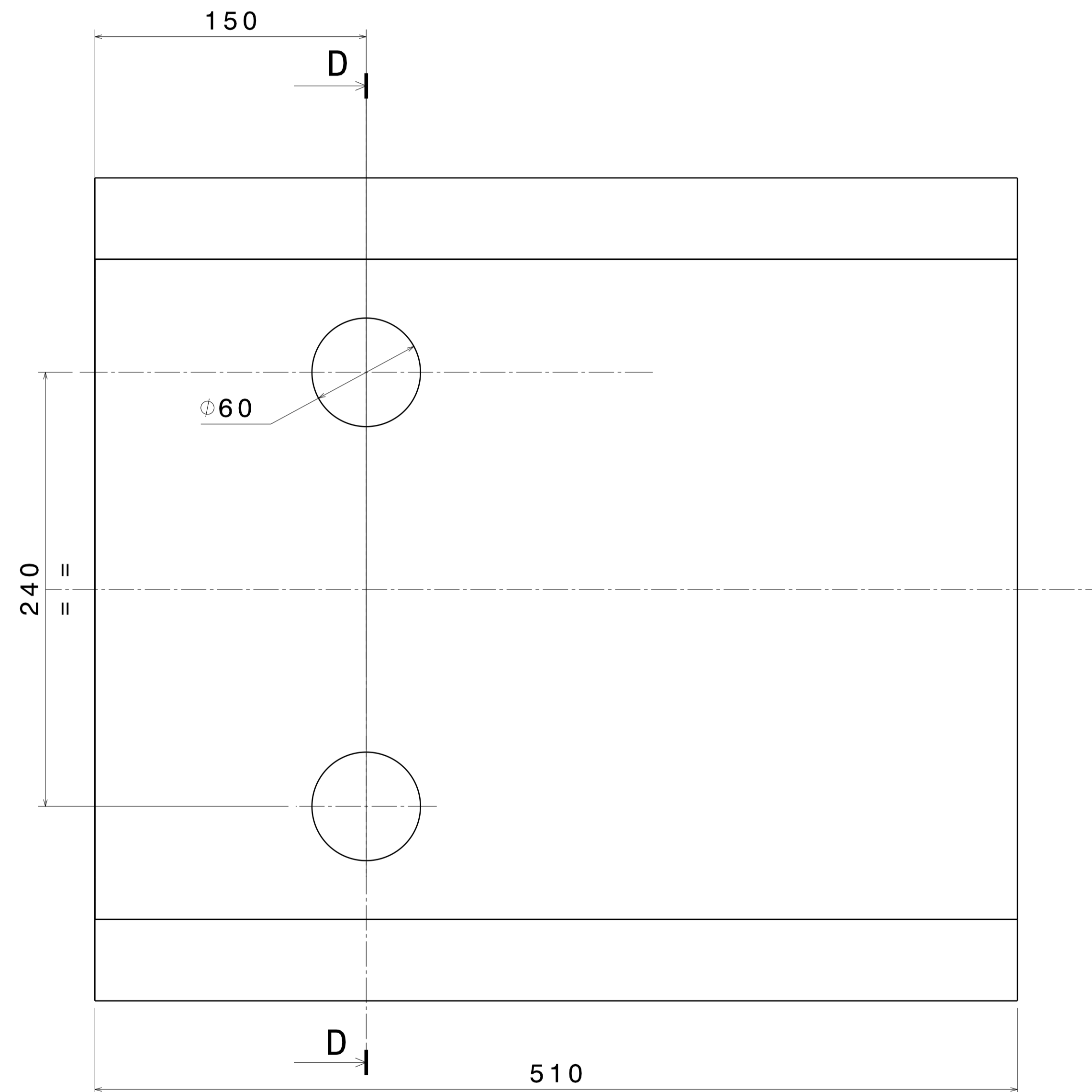

Auxiliary view C
Scale: 1:2

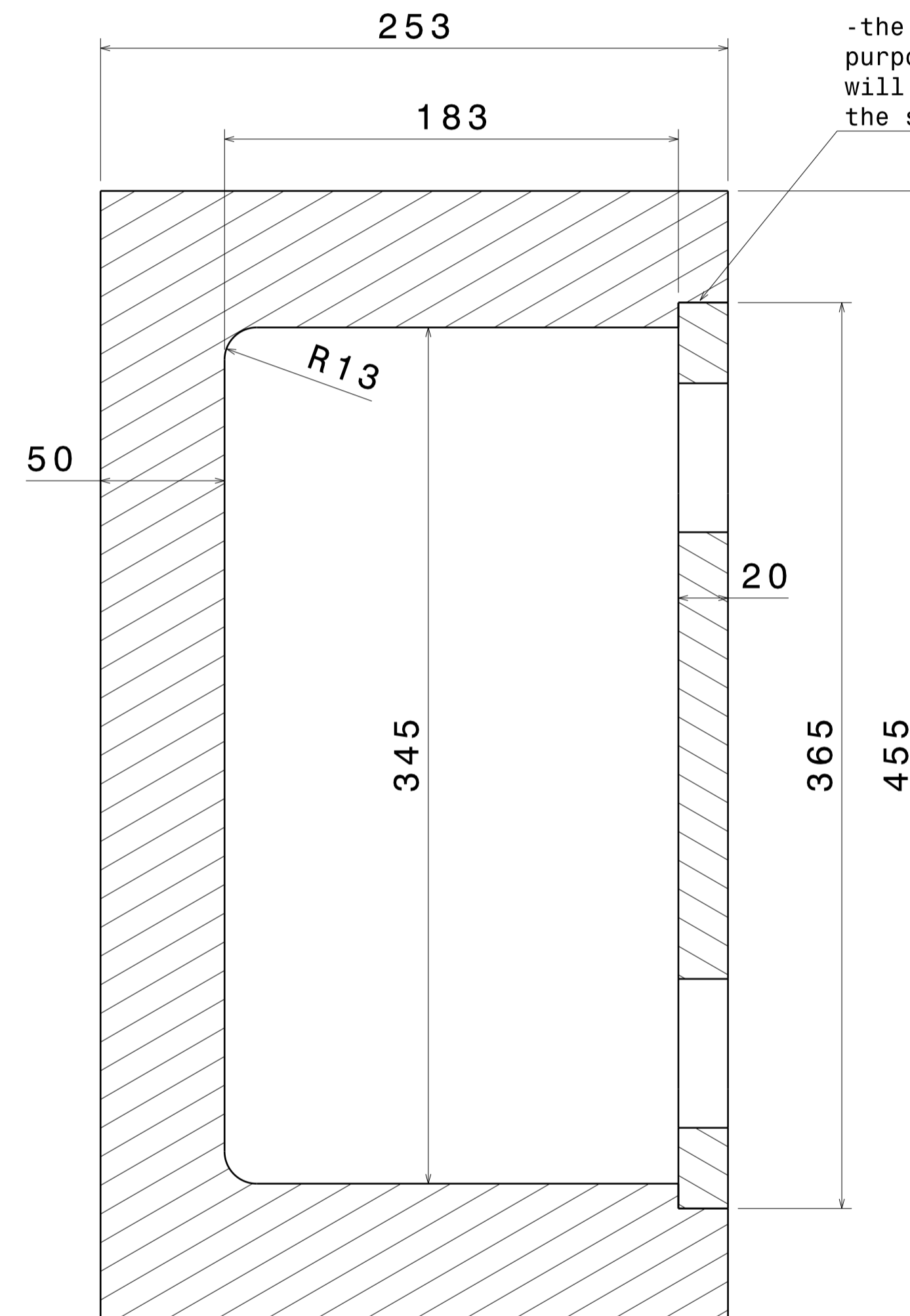

Section view D-D
Scale: 1:2

NOTE:

- DIN ISO 2768-1 & 2768-2 general medium tolerance class for all machining unless otherwise specified
- APPLY ROUGHNESS Ra 3.2 UNLESS OTHERWISE SPECIFIED
- UPDATED FOR AGREEMENT WITH DRAWING N°: DD-JT60TF-ASG-13403

DRAWING FOR ASG-SUPERCONDUCTOR

FOR CONTRACT				ref. to 3D CatProduct: 010301-203008			
CONFIDENTIAL UNLESS AUTHORISED <small>The information on this drawing is confidential under the terms of the BA agreement. This information shall not be transmitted to anyone who is not authorised to receive it.</small>		APPROVED BY A.CUCCHIARO		Fusion <small>Italy-Frascati Research Centre</small>		CUSTOMER: Fusion-for-Energy	
REV DATE 28-05-2012		CHECKED BY		DRAWING TITLE MOCK UP: STRAIGHT SAMPLE 50 CENTIMETRE LONG OF THE CASING			
FIRST ISSUE DATE 27/07/2011		SCALE NTS		CONTROLLED BY G.M.POLLI		CODE ENEA ID: DD-JT60TF-NCO	
DRAWN BY G. BROLATTI		SHEET SIZE A1		FIRST ANGLE PROJECTION 		WBS LEVELS 3	
010301		Drawing Number 503008		SHEET 01		REVISION 03	
				MATERIALITY			

DIMENSIONS RELATE TO ROOM TEMPERATURE (293K)

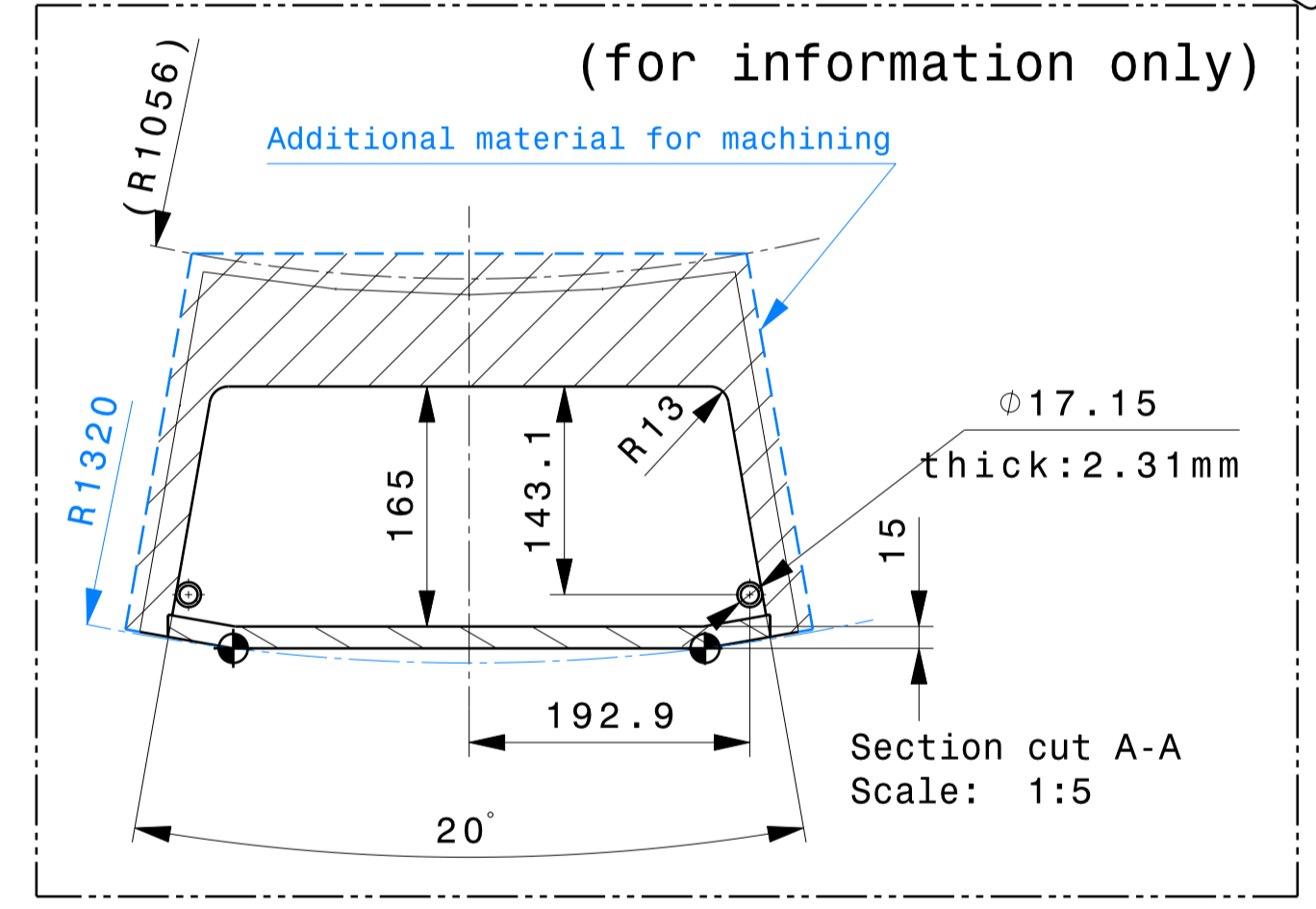
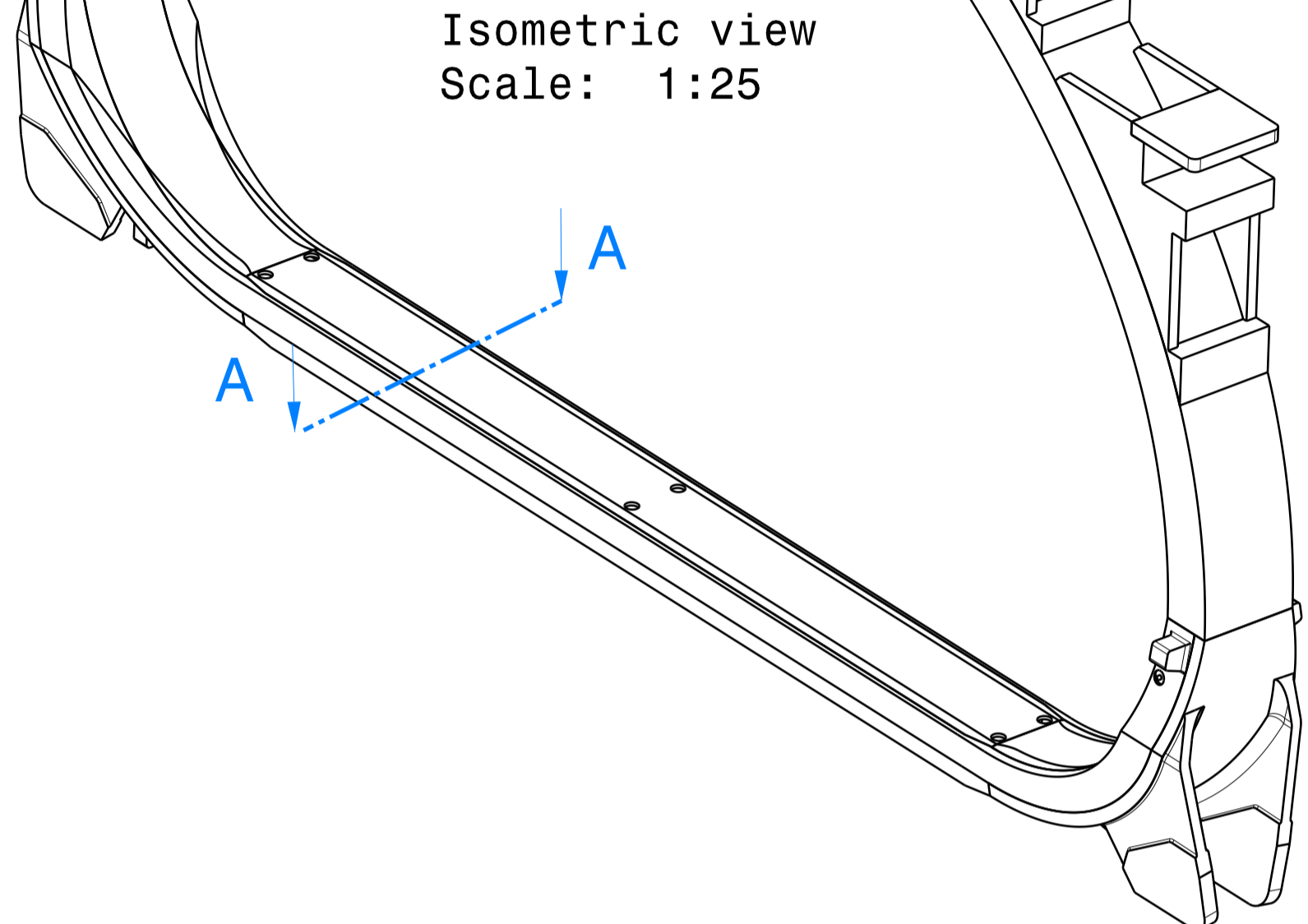
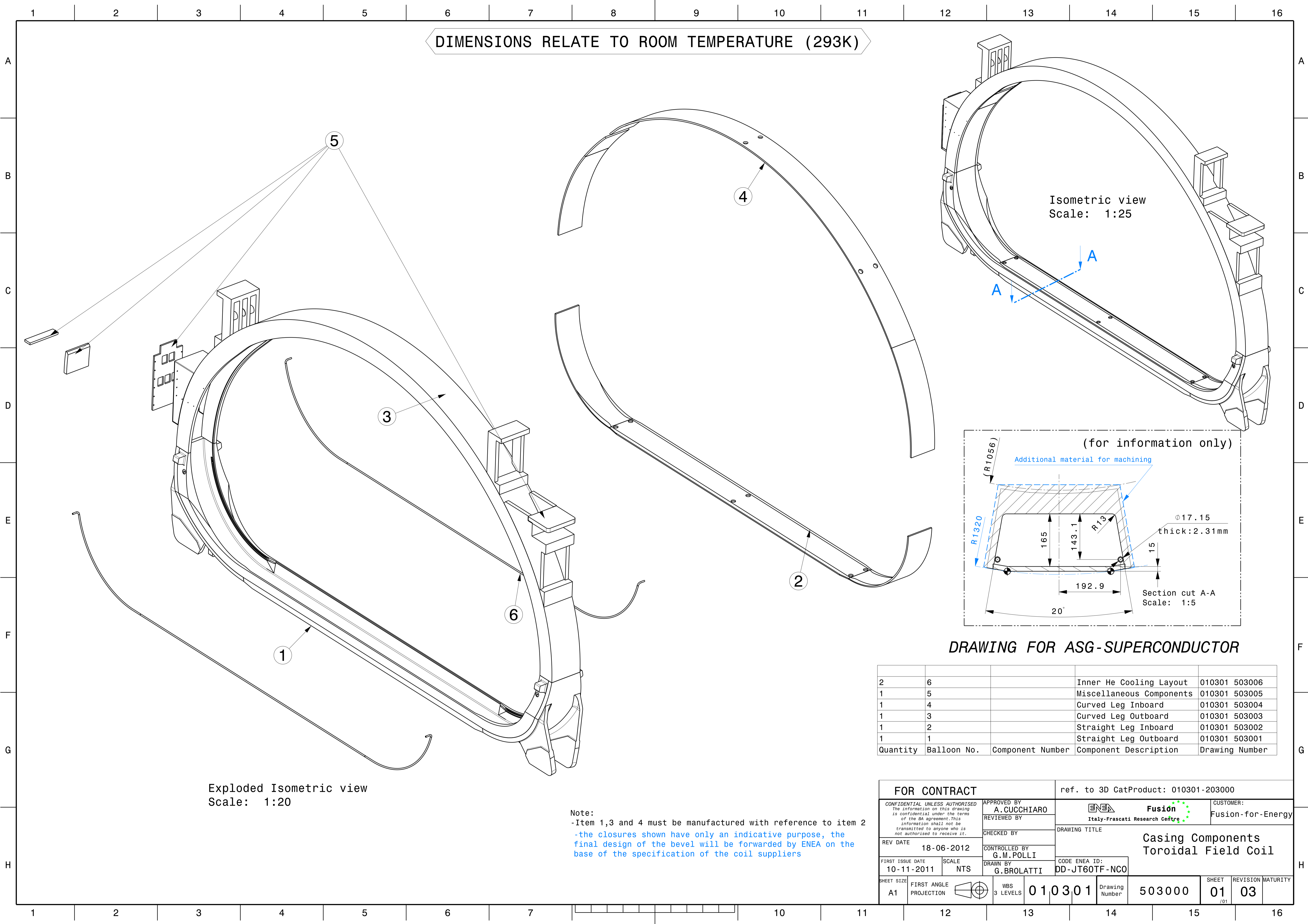

Exploded Isometric view
Scale: 1:20

Note:
-Item 1,3 and 4 must be manufactured with reference to item 2
-the closures shown have only an indicative purpose, the final design of the bevel will be forwarded by ENEA on the base of the specification of the coil suppliers

DRAWING FOR ASG-SUPERCONDUCTOR

2	6		Inner He Cooling Layout	010301 503006
1	5		Miscellaneous Components	010301 503005
1	4		Curved Leg Inboard	010301 503004
1	3		Curved Leg Outboard	010301 503003
1	2		Straight Leg Inboard	010301 503002
1	1		Straight Leg Outboard	010301 503001
Quantity	Balloon No.	Component Number	Component Description	Drawing Number

FOR CONTRACT		ref. to 3D CatProduct: 010301-203000		
<small>CONFIDENTIAL UNLESS AUTHORISED</small>		APPROVED BY A. CUCCHIARO	 Fusion Italy-Frascati Research Centre	CUSTOMER: Fusion-for-Energy
<small>The information on this drawing is confidential under the terms of the BA agreement. This information shall not be transmitted to anyone who is not authorised to receive it.</small>		REVIEWED BY		DRAWING TITLE Casing Components Toroidal Field Coil
REV DATE 18-06-2012	SCALE NTS	CHECKED BY	CONTROLLED BY G.M.POLLI	CODE ENEA ID: DD-JT60TF-NCO
FIRST ISSUE DATE 10-11-2011		DRAWN BY G.BROLATTI		
SHEET SIZE A1	FIRST ANGLE PROJECTION	WBS LEVELS 3 LEVELS	010301 Drawing Number	503000 SHEET 01 /01
				REVISION 03 Maturity

ITEM No	DRAWING No	DESCRIPTION	NO OFF	NO ORDERED	MATERIAL	SUPPLIER	DATE ORDERED	DATE DELIVERED	REMARKS
1	010301-503001	STRAIGHT LEG OUTBOARD							
2	010301-503002	STRAIGHT LEG INBOARD							
3	010301-503003	CURVED LEG OUTBOARD							
4	010301-503004	CURVED LEG INBOARD							
5	010301-503005	MISCELLANEUS COMPONENTS							
6	010301-503006	INNER He COOLING LAYOUT							
7	010301-503007	MOCK-UP STRAIGHT BEAM 1m LONG							
8	010301-503008	MOCK-UP STRAIGHT SAMPLE 50cm LONG							
9									
10									
11									
12									
13									
14									
15									
16									
17									
18									
19									
20									
21									
22									
23									
24									

ENEA **Fusion**
Italy-Frascati Research Centre

00	01	02	03	ISSUE
10-11-11	20-12-11	15-02-12	18-06-12	DATE
A	TENDER	CONTRACT		MATURITY

TITLE:-

DRN	GBROL
CHKD	GMPOL
APPD	ACUCC

CONFIDENTIAL UNLESS AUTHORISED
The information on this drawing is confidential under the terms of the BA agreement. This information shall not be transmitted to anyone who is not authorised to receive it.

CONTRACTOR: ASG-SUPERCONDUCTOR

ITEM LIST FOR CONTRACT

* 010301	503000
----------	--------

SHEET NO. 1 OF 1 SHEETS

PLANNING NOTES

Item list

**JT60-SA CASING COMPONENTS
TOROIDAL FIELD COIL**

C.A.D. DRAWN NOT TO BE MODIFIED BY HAND

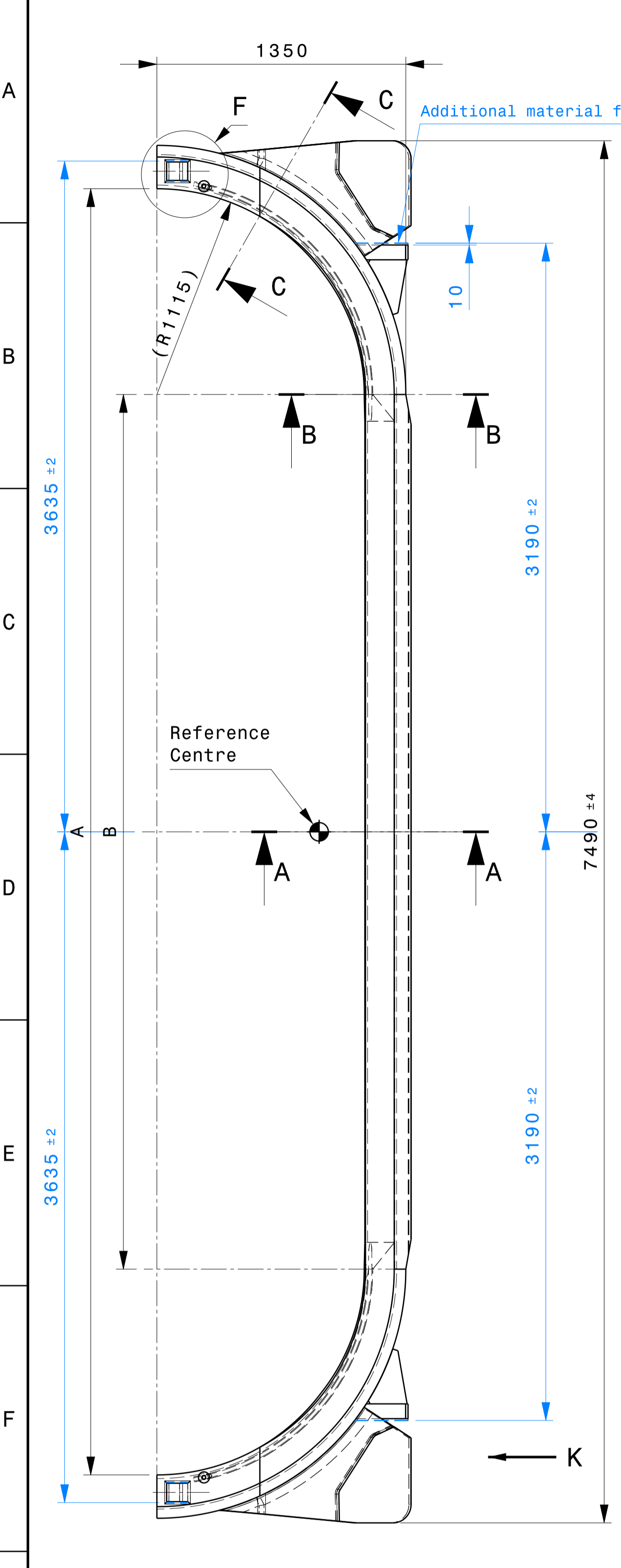

Front view
Scale: 1:20

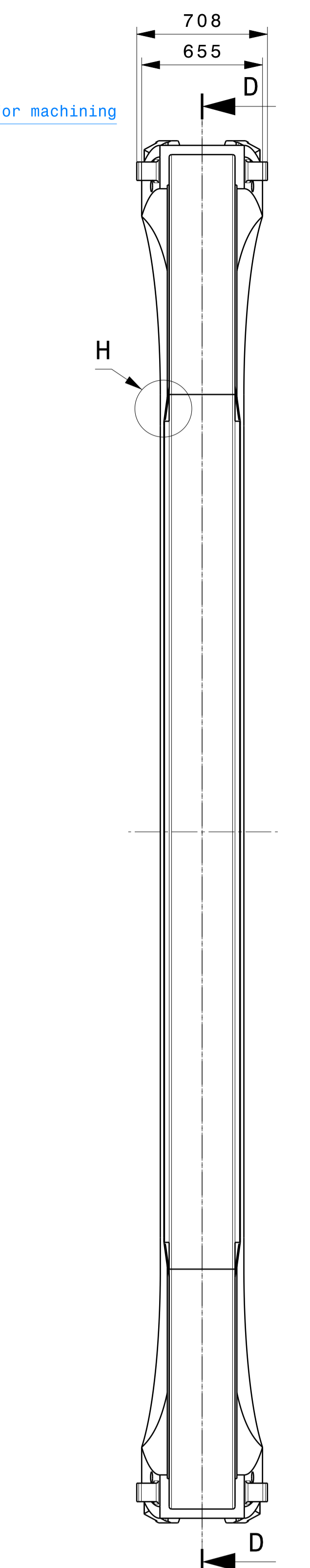

Left view
Scale: 1:20

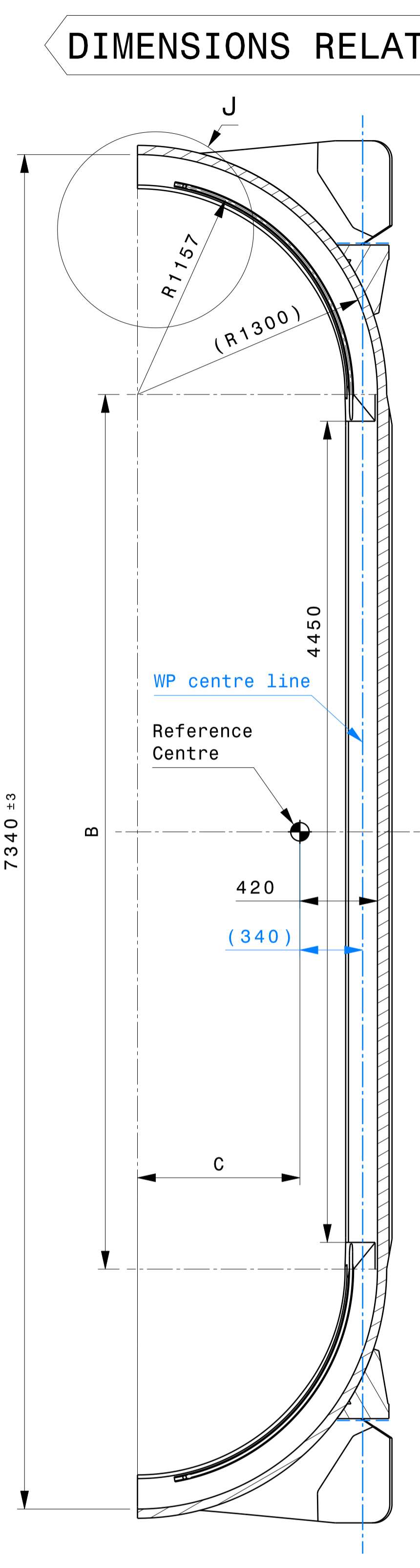

Section D-D
Scale: 1:20

DIMENSIONS RELATE TO ROOM TEMPERATURE (293K)

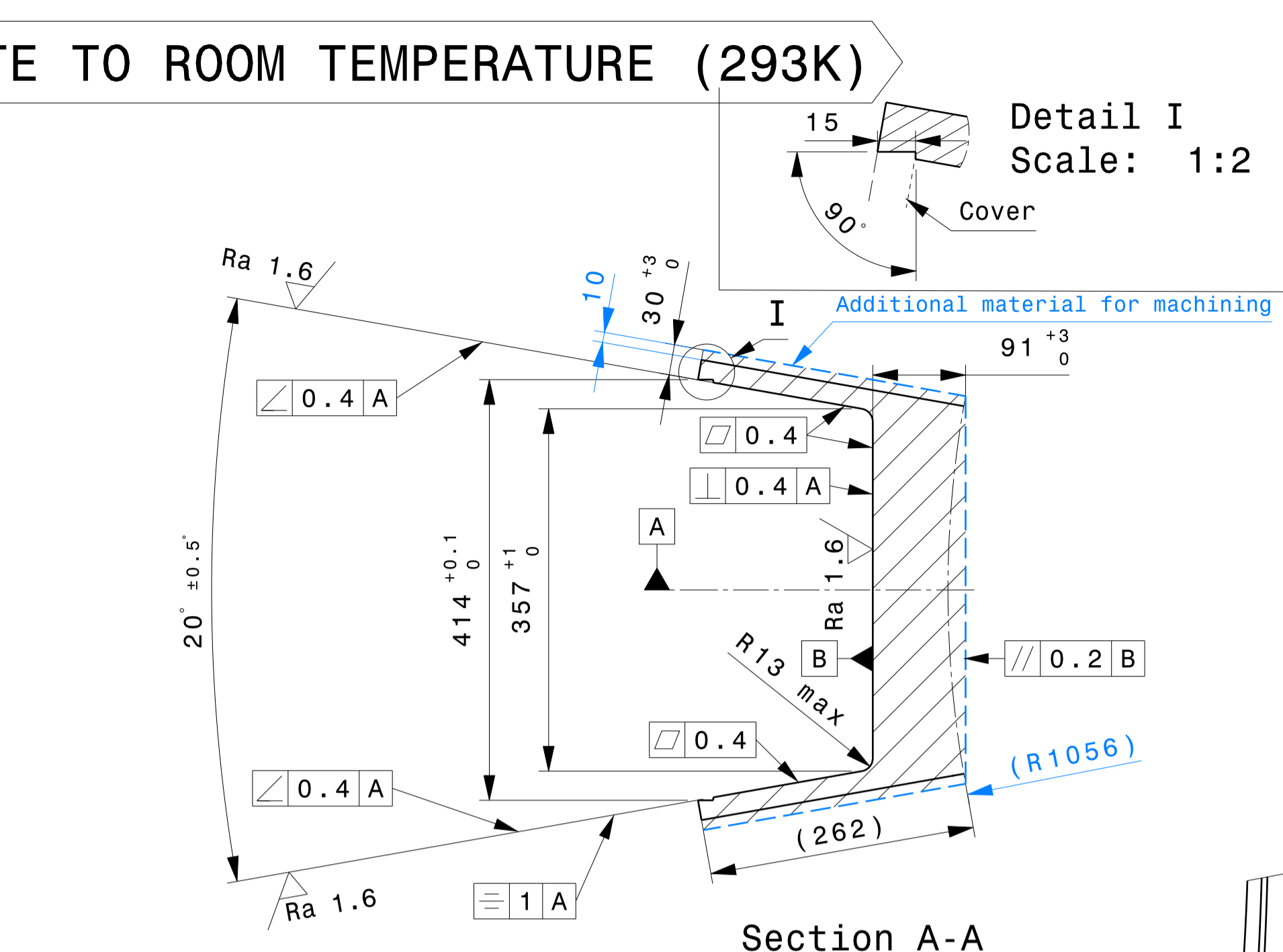

Section A-A
Scale: 1:5

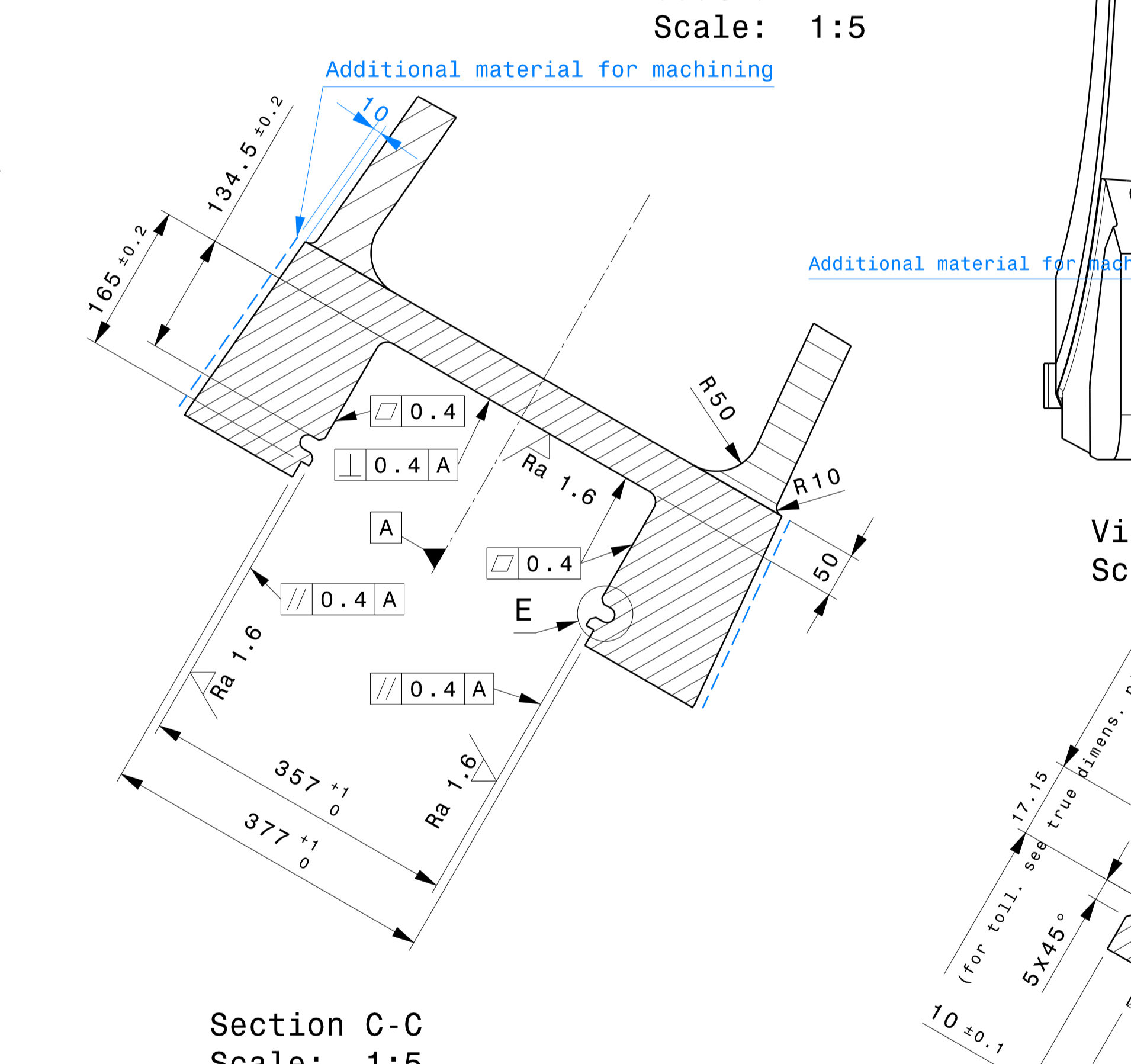

Section C-C
Scale: 1:5

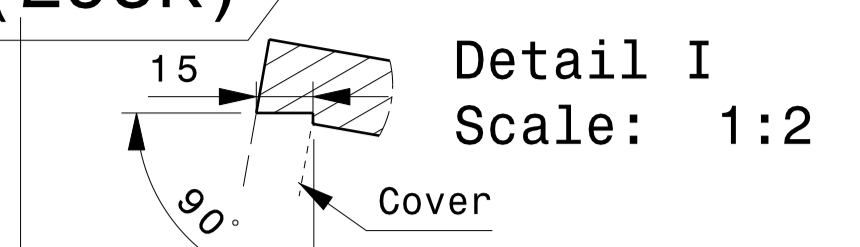

Detail I
Scale: 1:2

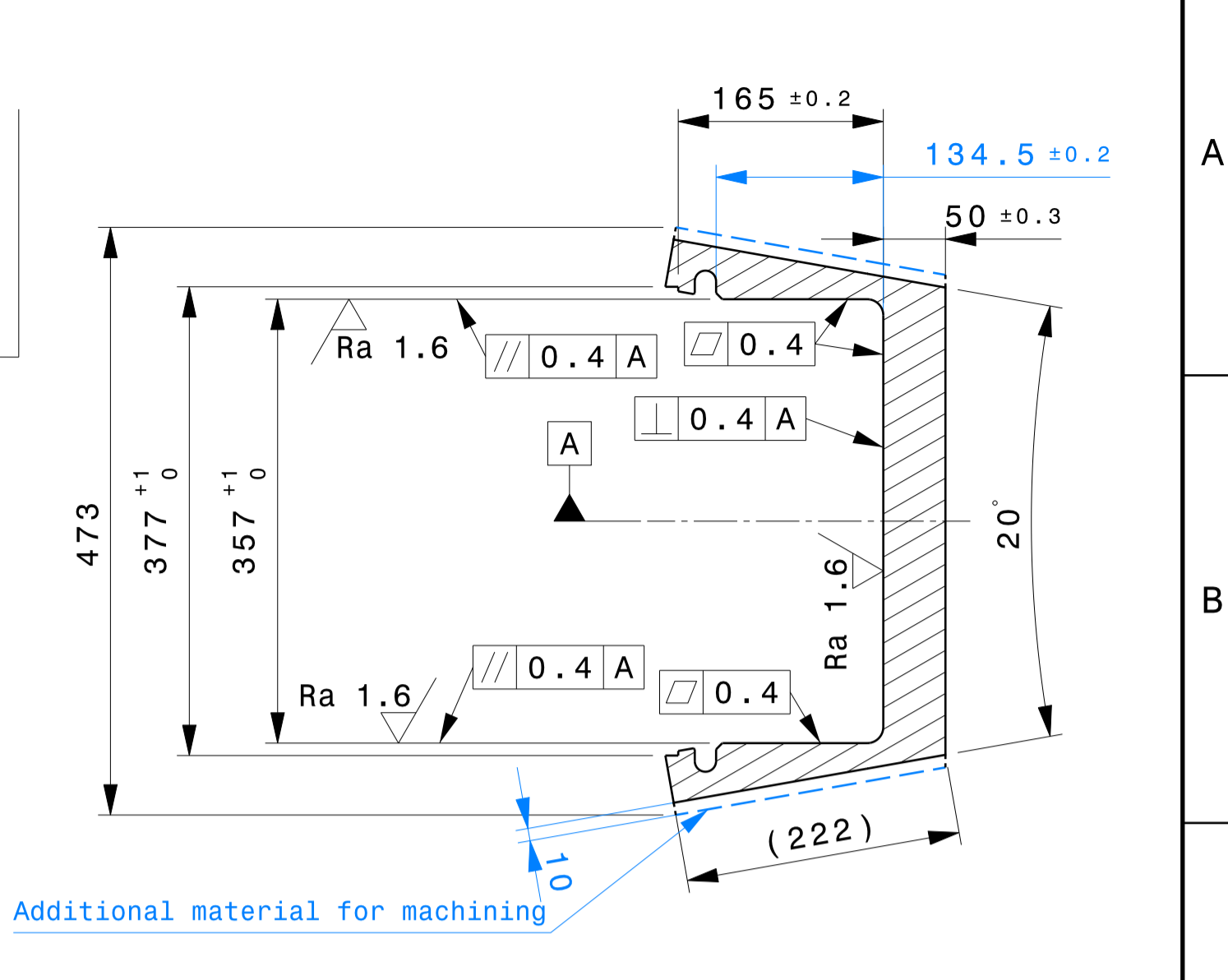

Section B-B
Scale: 1:5

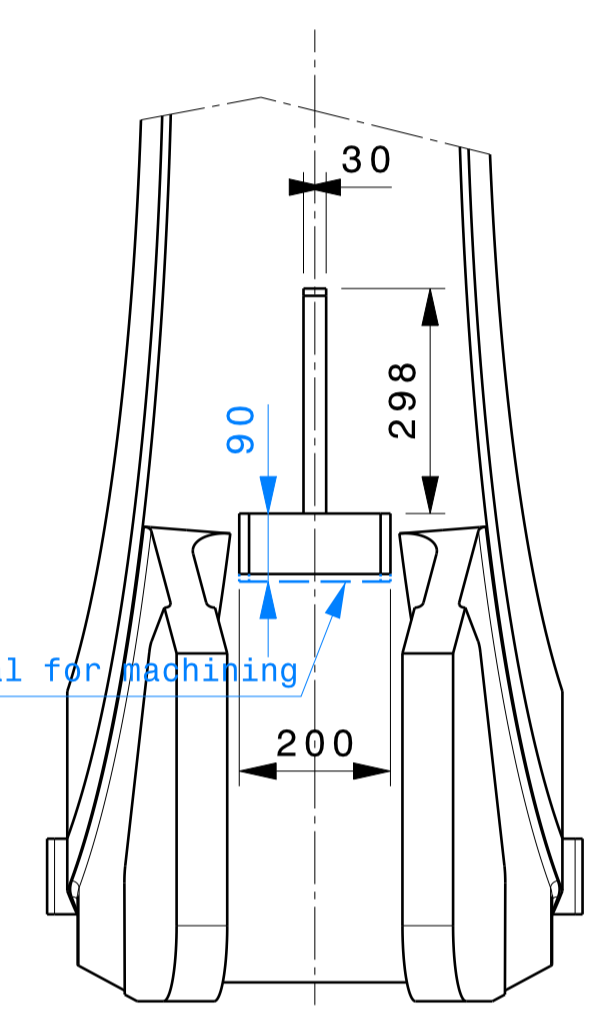

View K
Scale: 1:10

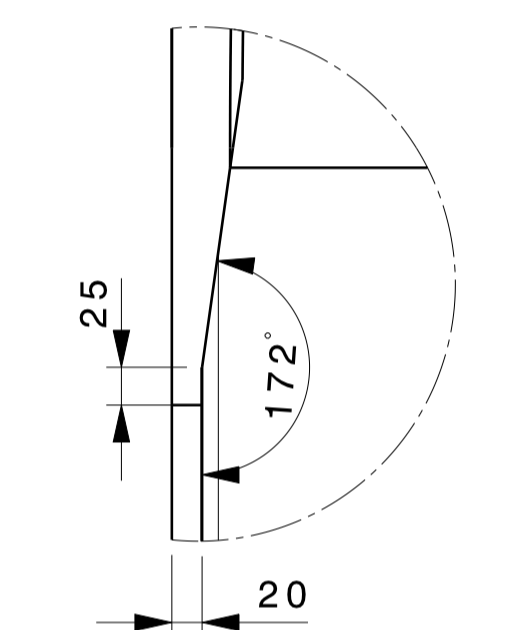

Detail H
Scale: 1:5

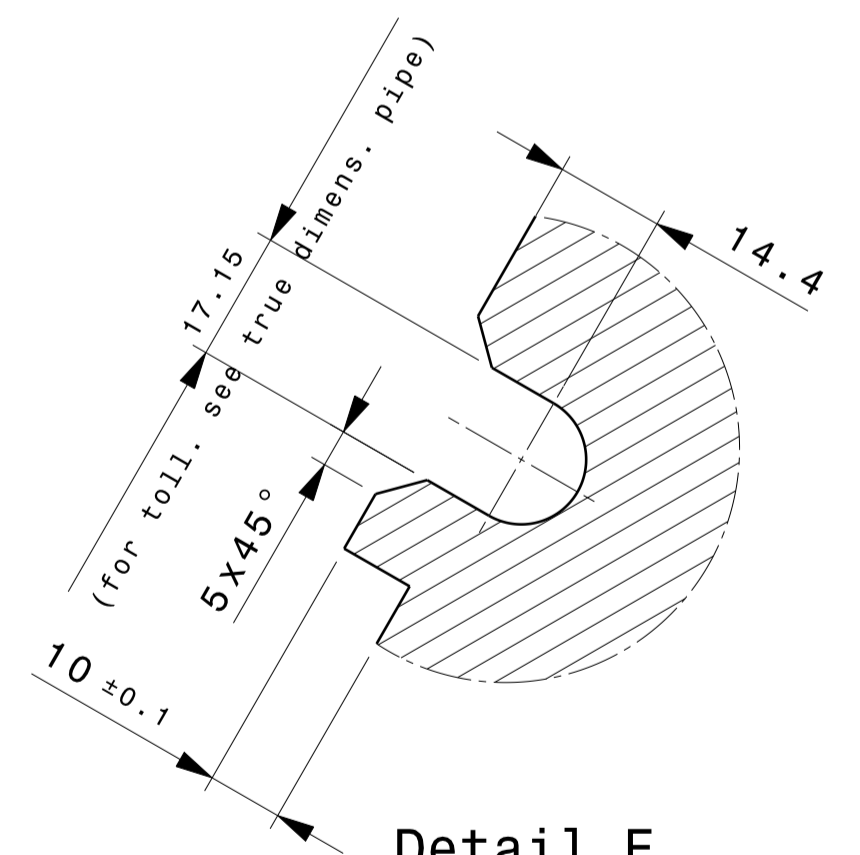

Detail E
Scale: 1:1

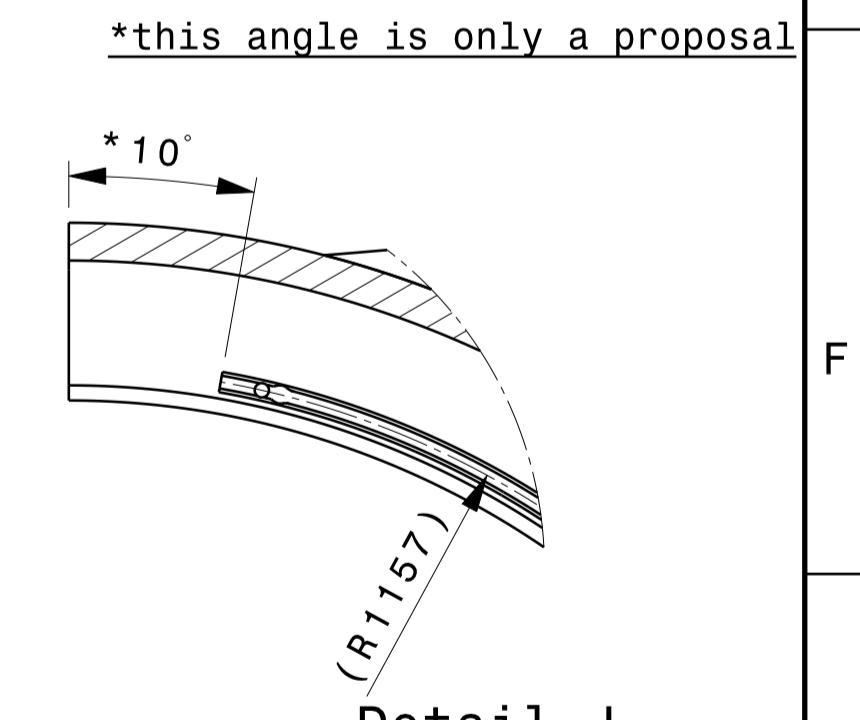

Detail J
Scale: 1:10

Note:
 -DIN ISO 2768-1 & 2768-2 general medium tolerance class for all machining unless otherwise specified
 -For dimensions A, B and C see drawing 010301 503002
 -APPLY ROUGHNESS Ra 3.2 UNLESS OTHERWISE SPECIFIED

DRAWING FOR ASG-SUPERCONDUCTOR

FOR CONTRACT		ref. to 3D CatProduct: 010301-203001	
CONFIDENTIAL UNLESS AUTHORISED <small>The information on this drawing is confidential under the terms of the BA agreement. This information shall not be transmitted to anyone who is not authorised to receive it.</small>	APPROVED BY A. CUCCHIARO	 Fusion Italy-Frascati Research Centre	CUSTOMER: Fusion-for-Energy
REV DATE 18-06-2012	CHECKED BY		DRAWING TITLE Straight Leg Outboard Toroidal Field Coil
FIRST ISSUE DATE 10-11-2011	SCALE NTS	CONTROLLED BY G.M.POLLI	CODE ENEA ID: DD-JT60TF-NCO
SHEET SIZE A1	FIRST ANGLE PROJECTION	WBS LEVELS 3	010301
		Drawing Number	503001
		SHEET	01
		REVISION	02
		MATURITY	

DIMENSIONS RELATE TO ROOM TEMPERATURE (293K)

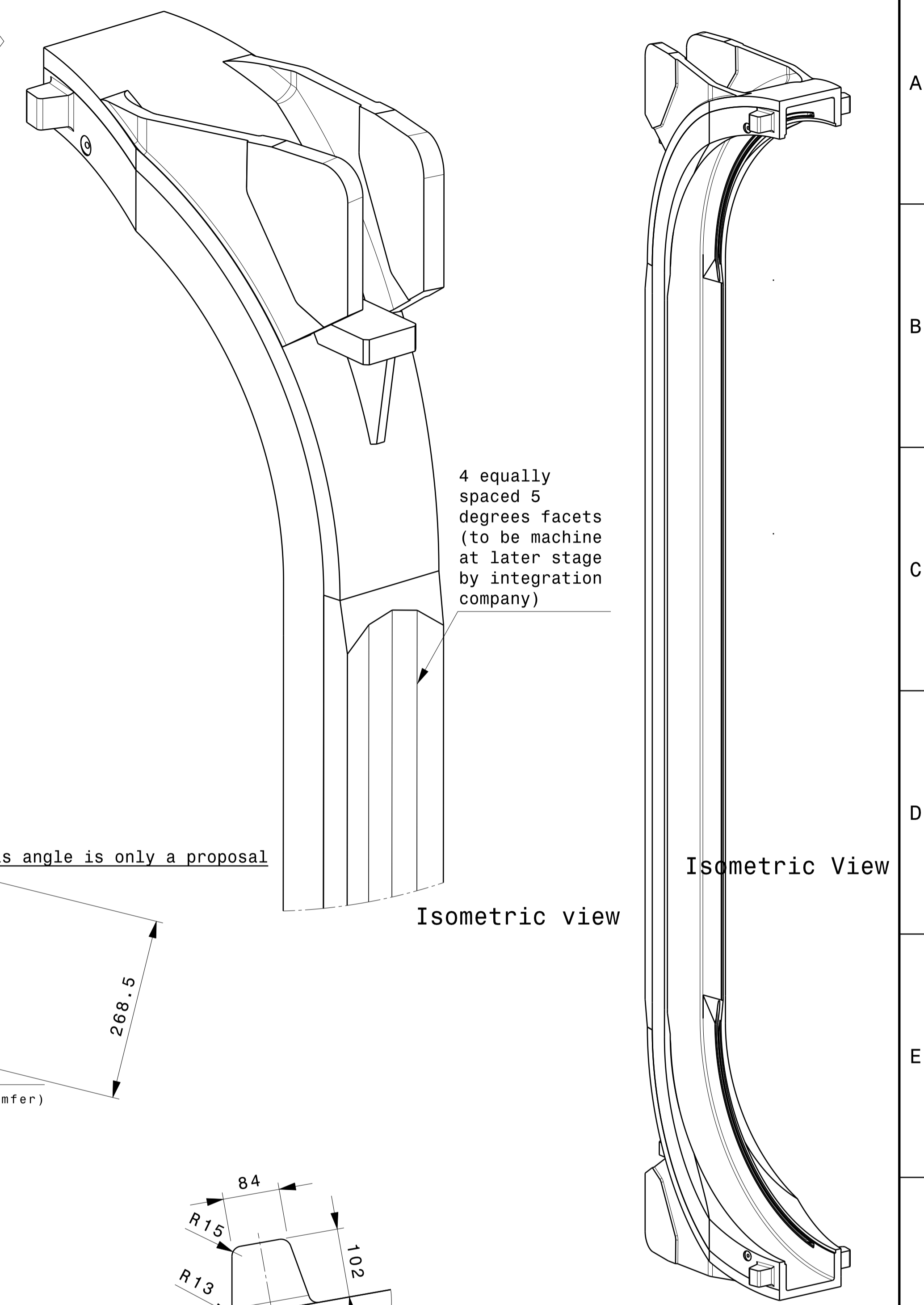
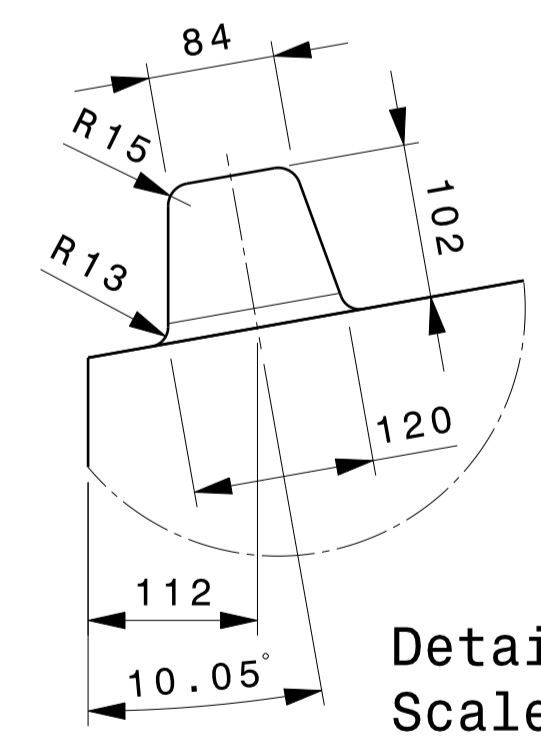
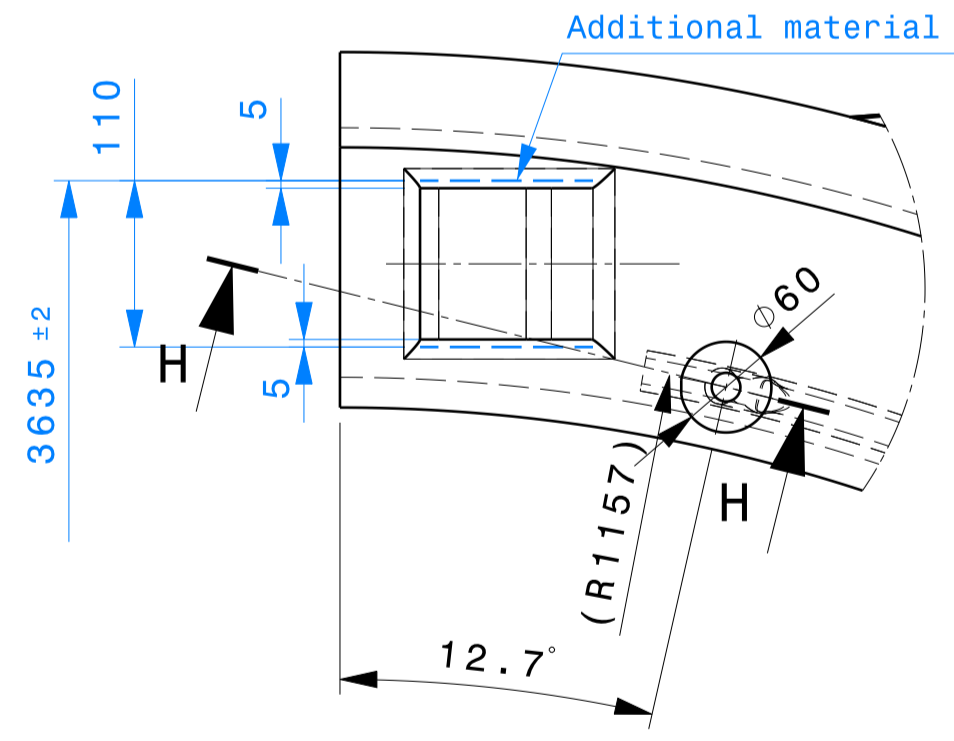
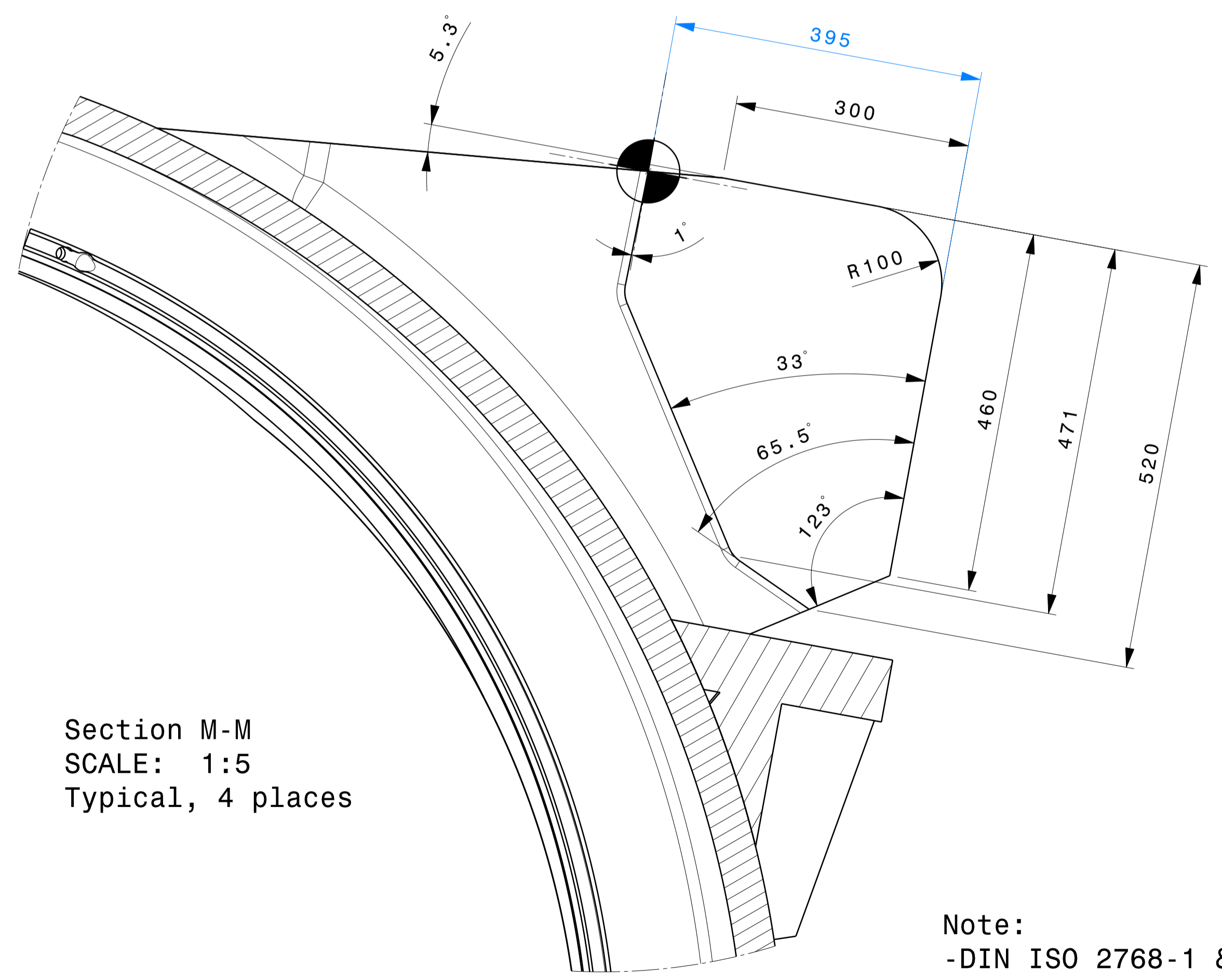
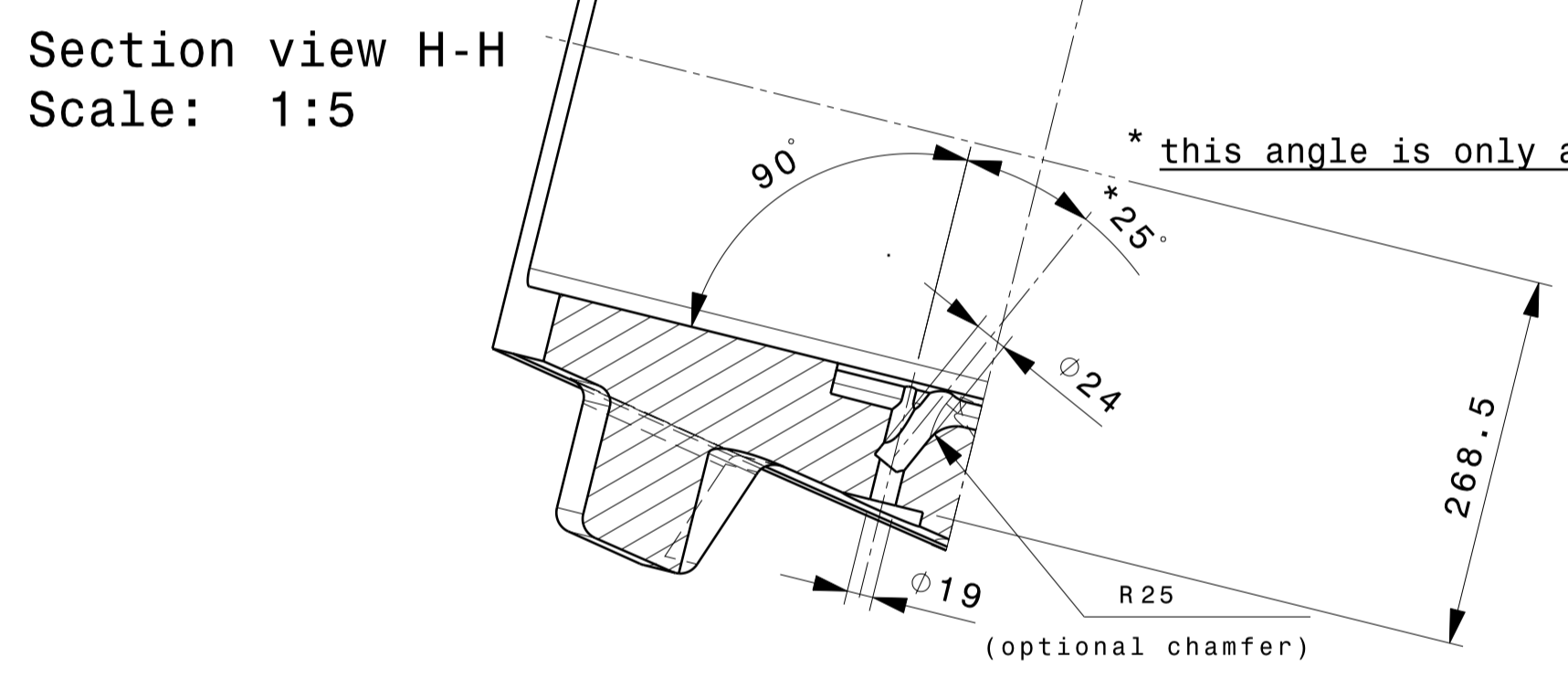
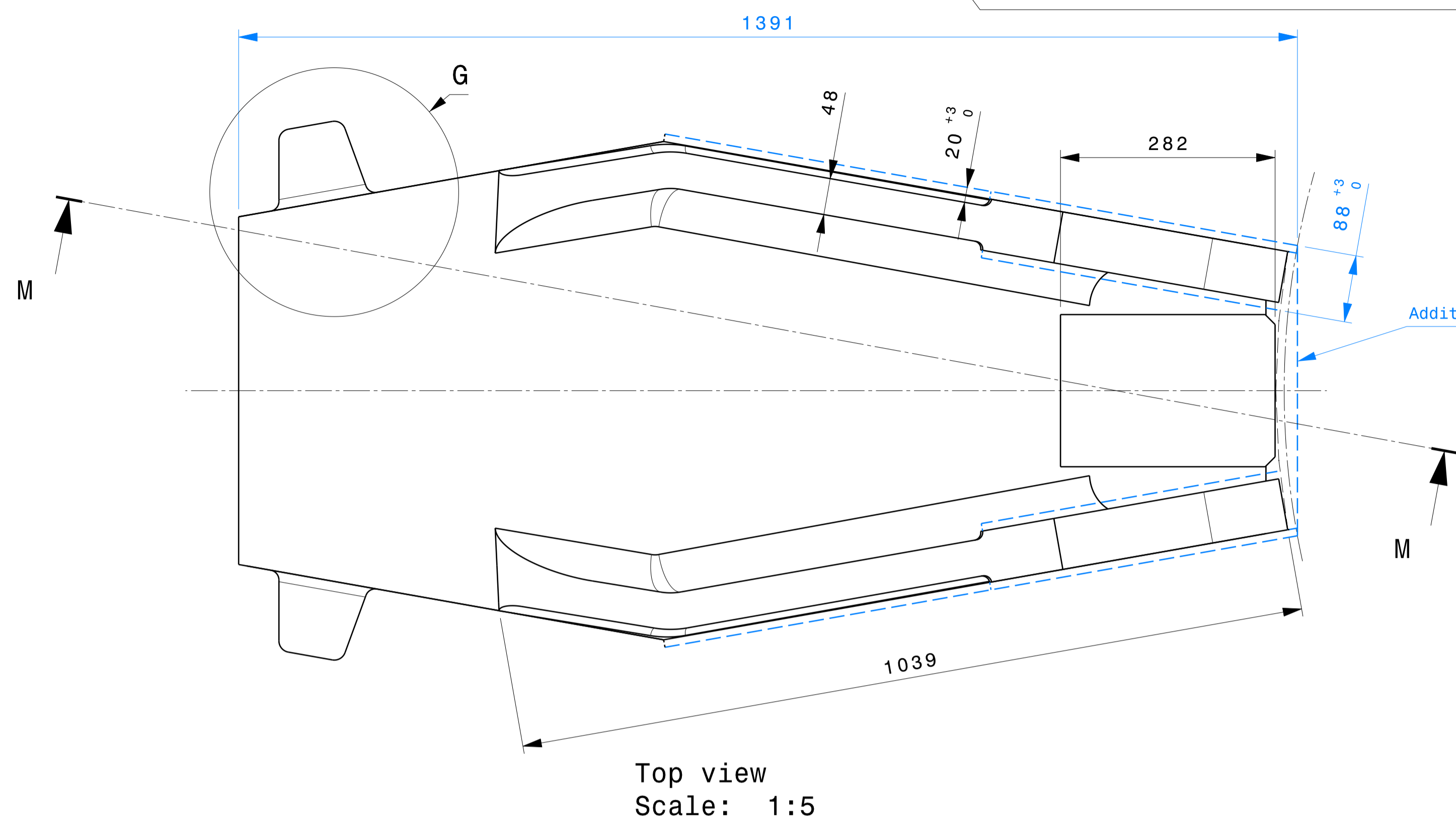

Note:
 -DIN ISO 2768-1 & 2768-2 general medium tolerance class for all machining unless otherwise specified
 -For dimensions A, B and C see drawing 010301 503002
 -APPLY ROUGHNESS Ra 3.2 UNLESS OTHERWISE SPECIFIED

DRAWING FOR ASG-SUPERCONDUCTOR

FOR CONTRACT		ref. to 3D CatProduct: 010301-203001	
CONFIDENTIAL UNLESS AUTHORISED <small>The information on this drawing is confidential under the terms of the BA agreement. This information shall not be transmitted to anyone who is not authorised to receive it.</small>		APPROVED BY A. CUCCHIARO	CUSTOMER: Fusion-for-Energy
REV DATE 18-06-2012		REVIEWED BY	DRAWING TITLE Straight Leg Outboard Toroidal Field Coil
FIRST ISSUE DATE 10-11-2011	SCALE NTS	CHECKED BY	
CONTROLLED BY G.M. POLLI		CODE ENEA ID: DD-JT60TF-NCO	
DRAWN BY G. BROLATTI		SHEET 02	
SHEET SIZE A1	FIRST ANGLE PROJECTION	WBS LEVELS 3 LEVELS	Drawing Number 503001
010301		REVISION 02	
Maturity		02	

DIMENSIONS RELATE TO ROOM TEMPERATURE (293K)

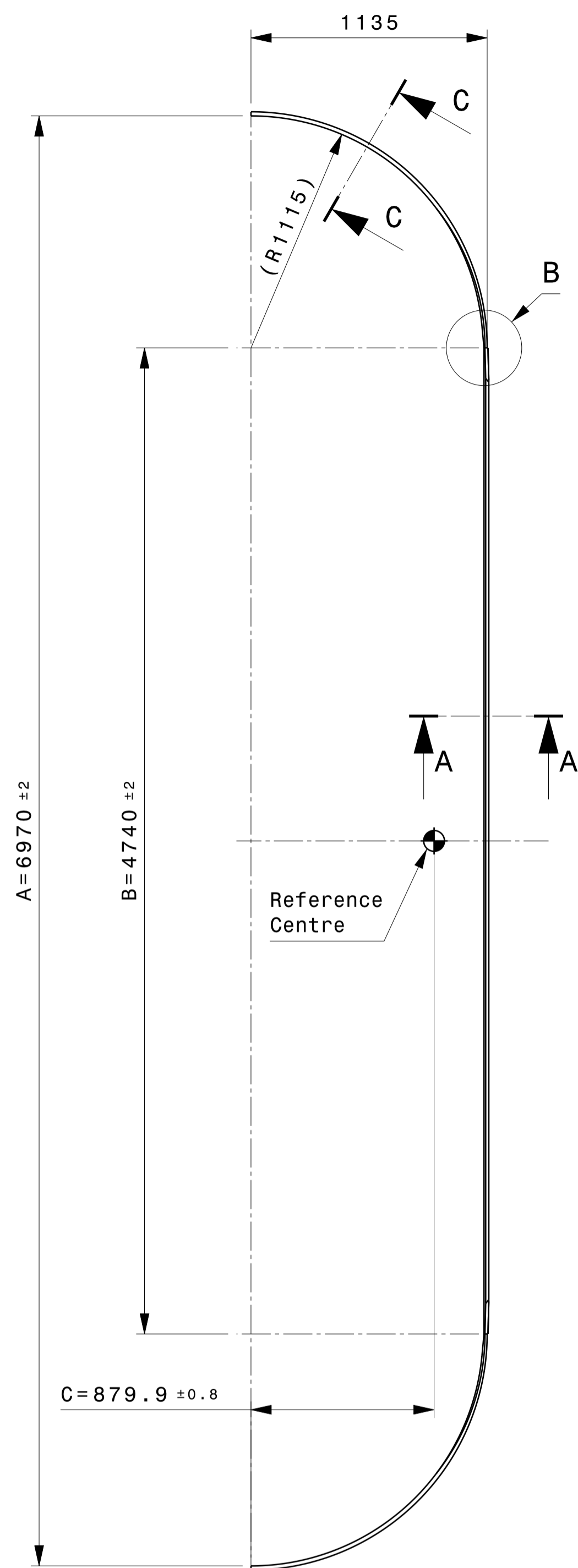

Front view
Scale: 1:20

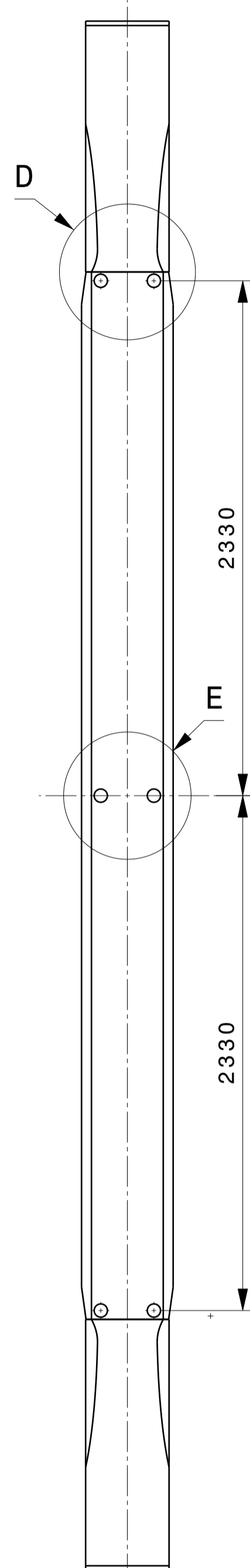

Left view
Scale: 1:20

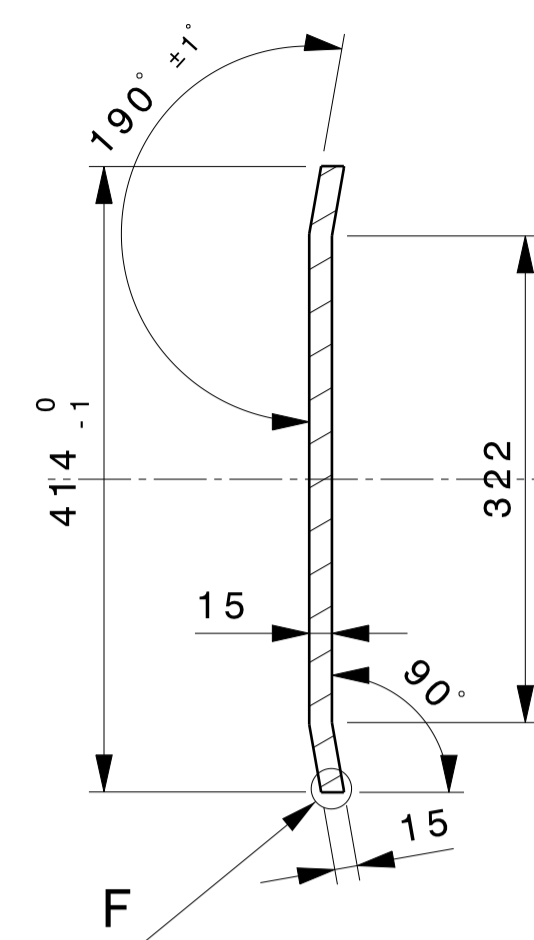

Section A-A
Scale: 1:5

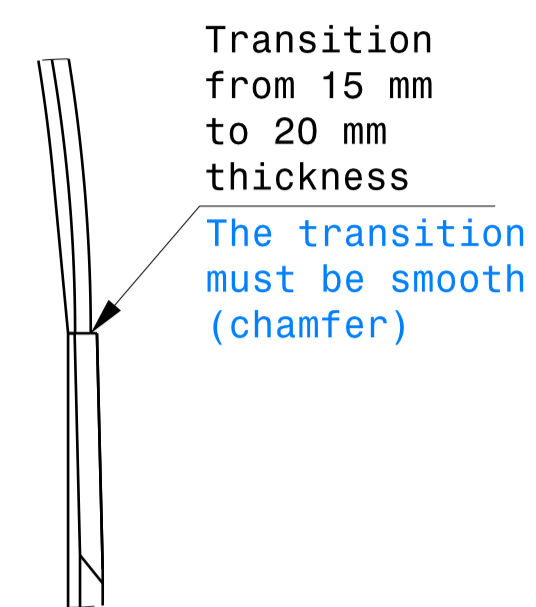

Detail B
Scale: 1:5

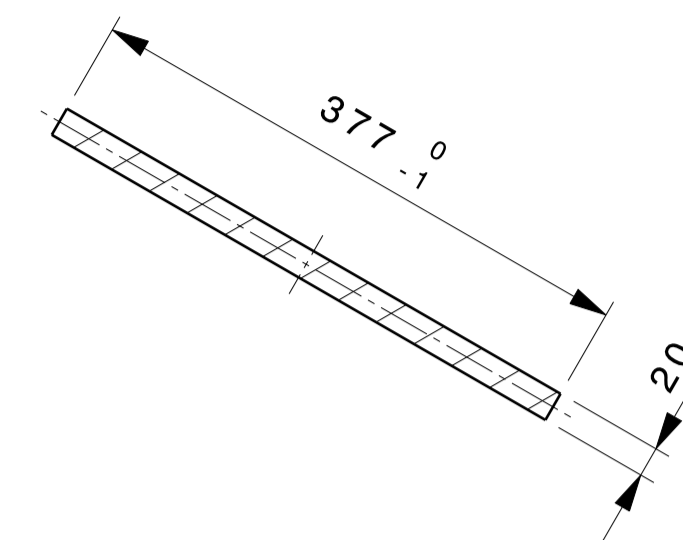

Section C-C
Scale: 1:5

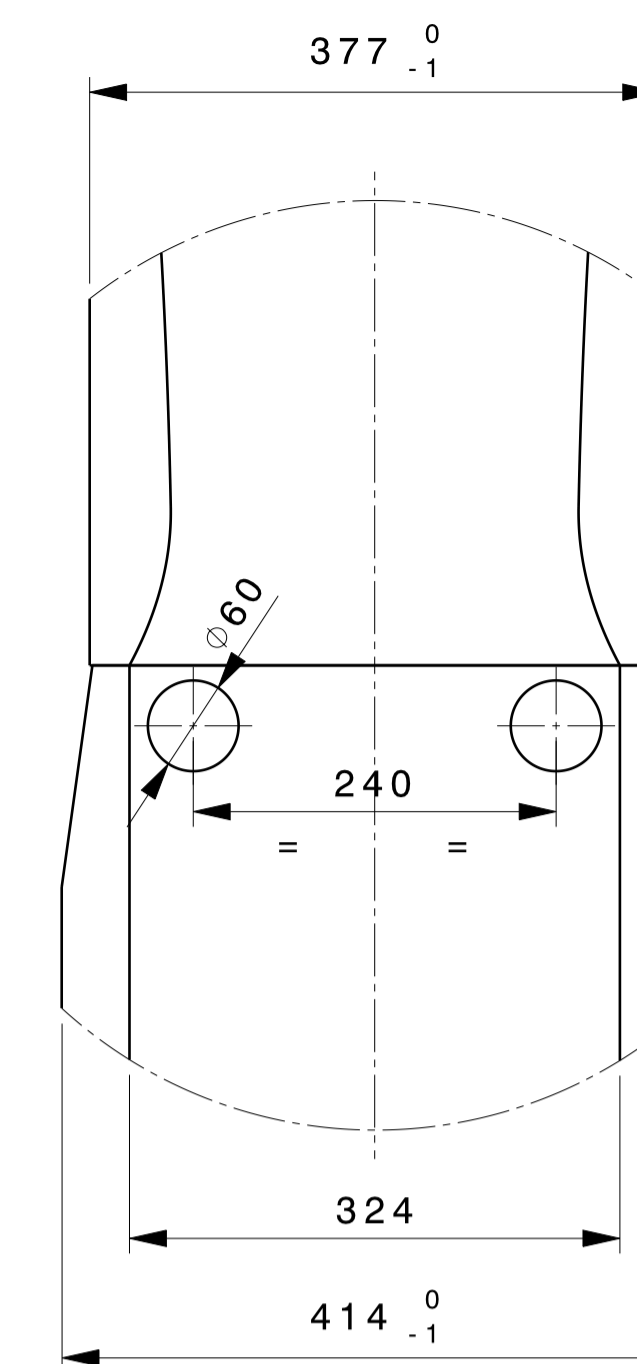

Detail D
Scale: 1:5

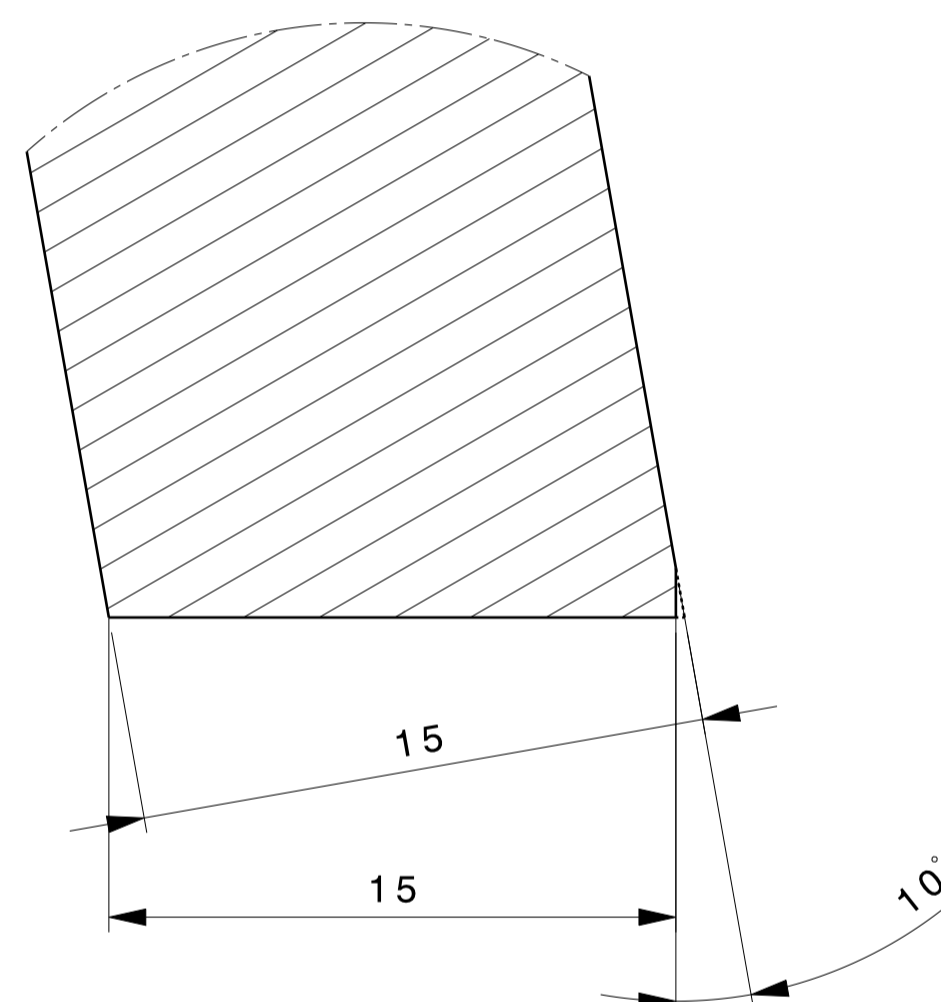

Detail F
Scale: 5:1

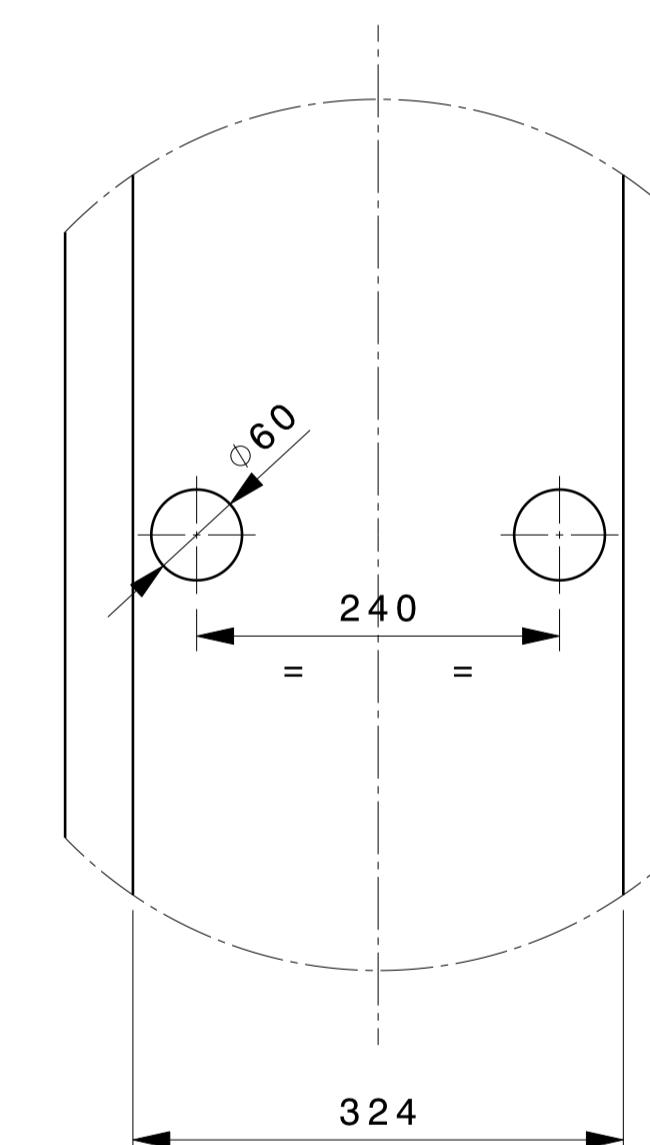

Detail E
Scale: 1:5

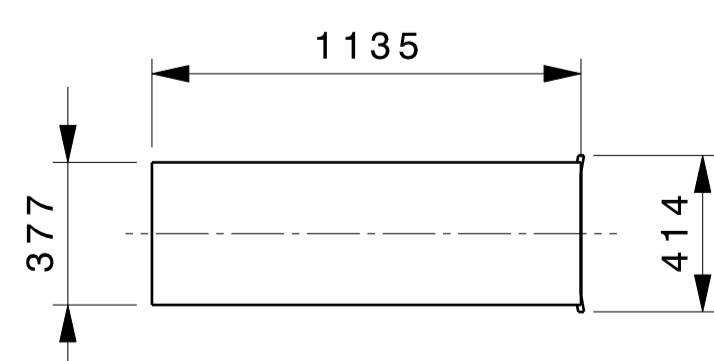

Top view
Scale: 1:20

Note:

- DIN ISO 2768-1 & 2768-2 general medium tolerance class for all machining unless otherwise specified
- A is required for machining of mating parts see drawing 010301 503001, 010301 503003, 010301 503004
- B is required for machining of mating part see drawing 010301 503001
- C is required for machining of mating parts see drawing 010301 503001, 010301 503003, 010301 503004
- APPLY ROUGHNESS Ra 3.2 UNLESS OTHERWISE SPECIFIED

DRAWING FOR ASG-SUPERCONDUCTOR

FOR CONTRACT		ref. to 3D CatProduct: 010301-203002	
CONFIDENTIAL UNLESS AUTHORISED <small>The information on this drawing is confidential under the terms of the BA agreement. This information shall not be transmitted to anyone who is not authorised to receive it.</small>		APPROVED BY A. CUCCHIARO	CUSTOMER: Fusion-for-Energy
REV DATE 18-06-2012		REVIEWED BY G.M. POLLI	DRAWING TITLE Straight leg inboard Toroidal Field Coil
FIRST ISSUE DATE 10-11-2011		CONTROLLED BY G.M. POLLI	
SCALE NTS		DRAWN BY G. BROLATTI	CODE ENEA ID: DD-JT60TF-NCO
SHEET SIZE A1	FIRST ANGLE PROJECTION	WBS LEVELS 3	Drawing Number 010301 503002
		SHEET 01	REVISION 03
		MATURITY	

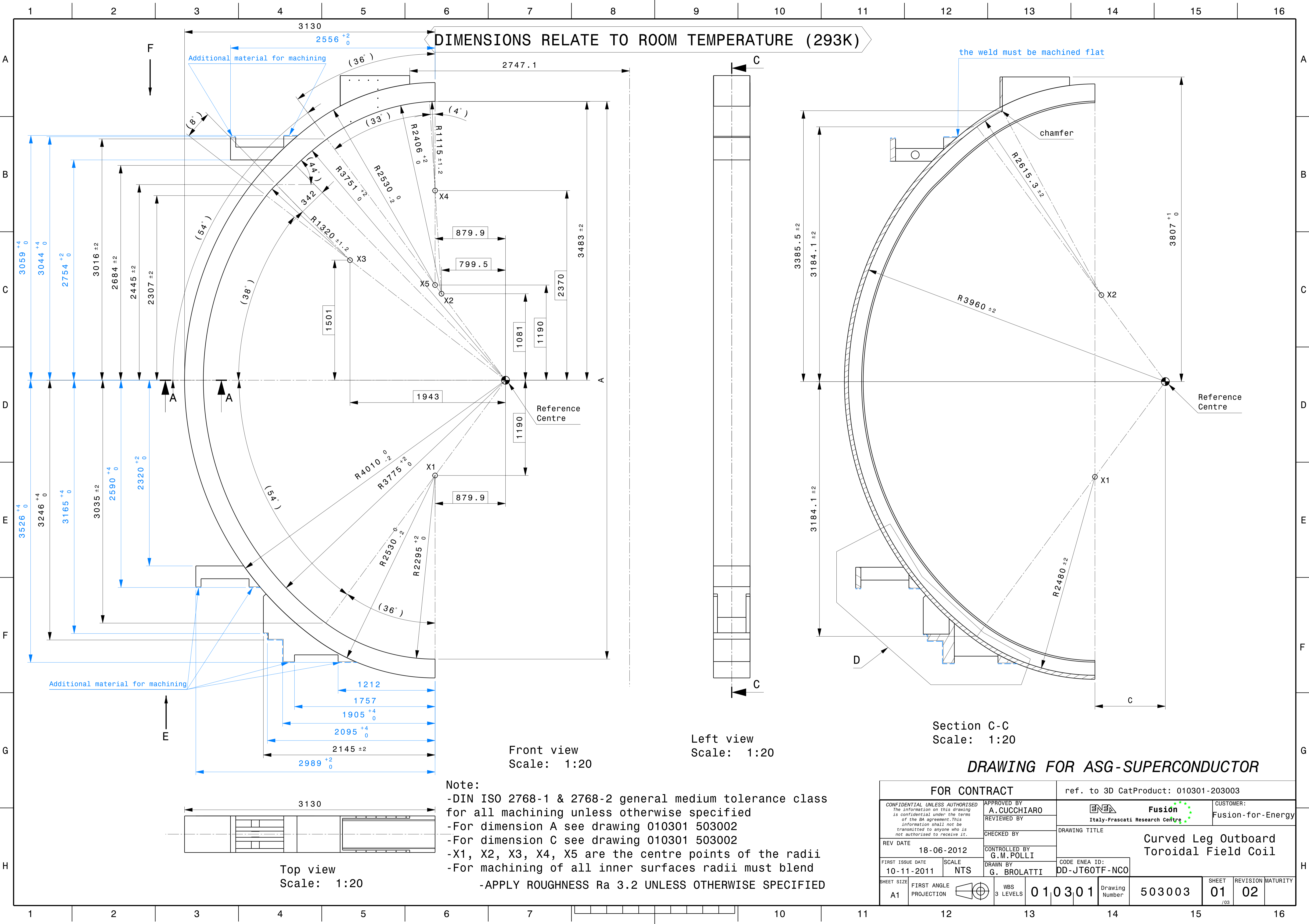

FOR CONTRACT		ref. to 3D CatProduct: 010301-203003	
<small>CONFIDENTIAL UNLESS AUTHORISED</small> <small>The information on this drawing is confidential under the terms of the BA agreement. This information shall not be transmitted to anyone who is not authorised to receive it.</small>	APPROVED BY A. CUCCHIARO	 Fusion <small>Italy-Frascati Research Centre</small>	CUSTOMER: Fusion-for-Energy
	REVIEWED BY		DRAWING TITLE Curved Leg Outboard Toroidal Field Coil
REV DATE 18-06-2012	CONTROLLED BY G.M. POLLI	CODE ENEA ID: DD-JT60TF-NCO	
FIRST ISSUE DATE 10-11-2011	SCALE NTS		
SHEET SIZE A1	FIRST ANGLE PROJECTION	WBS LEVELS 3 LEVELS	010301
		Drawing Number 503003	SHEET 01
			REVISION 02
			MATURITY

DIMENSIONS RELATE TO ROOM TEMPERATURE (293K)

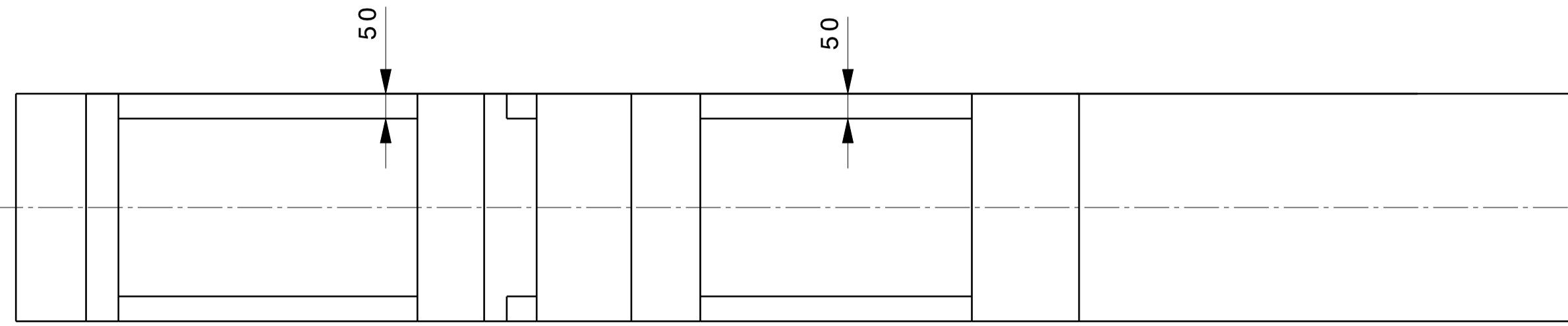

View E
Scale: 1:10

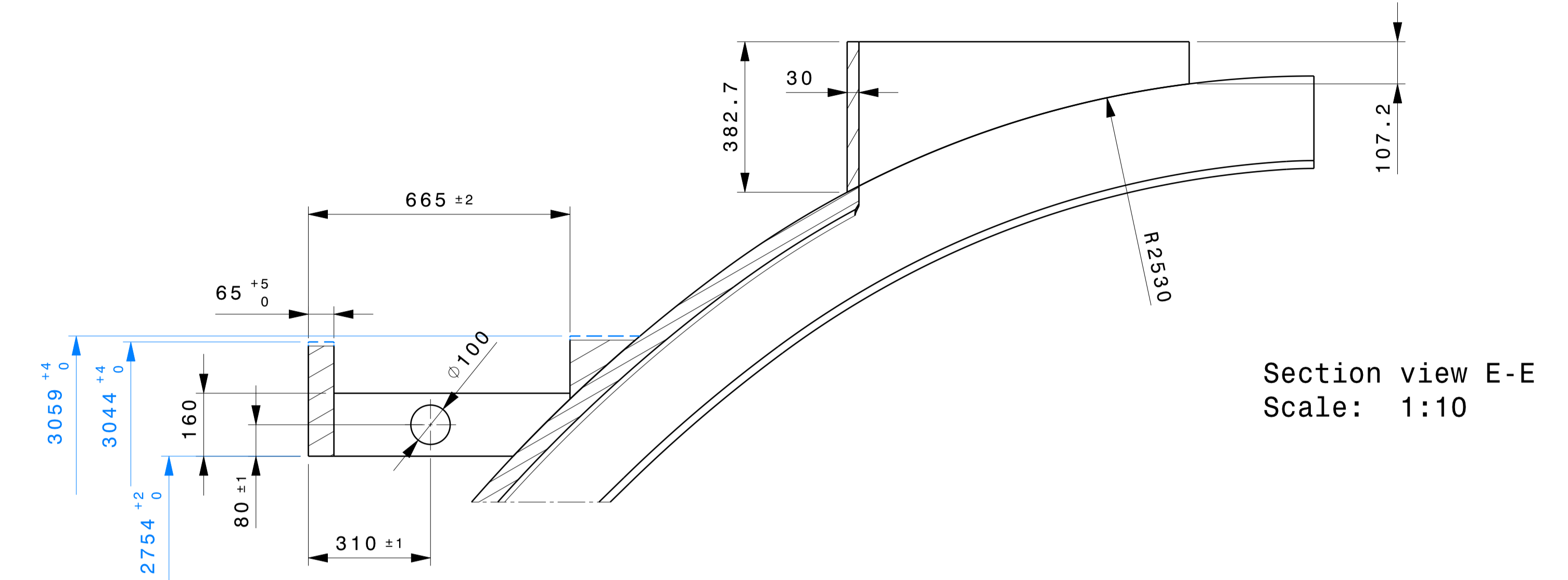

Section view E-E
Scale: 1:10

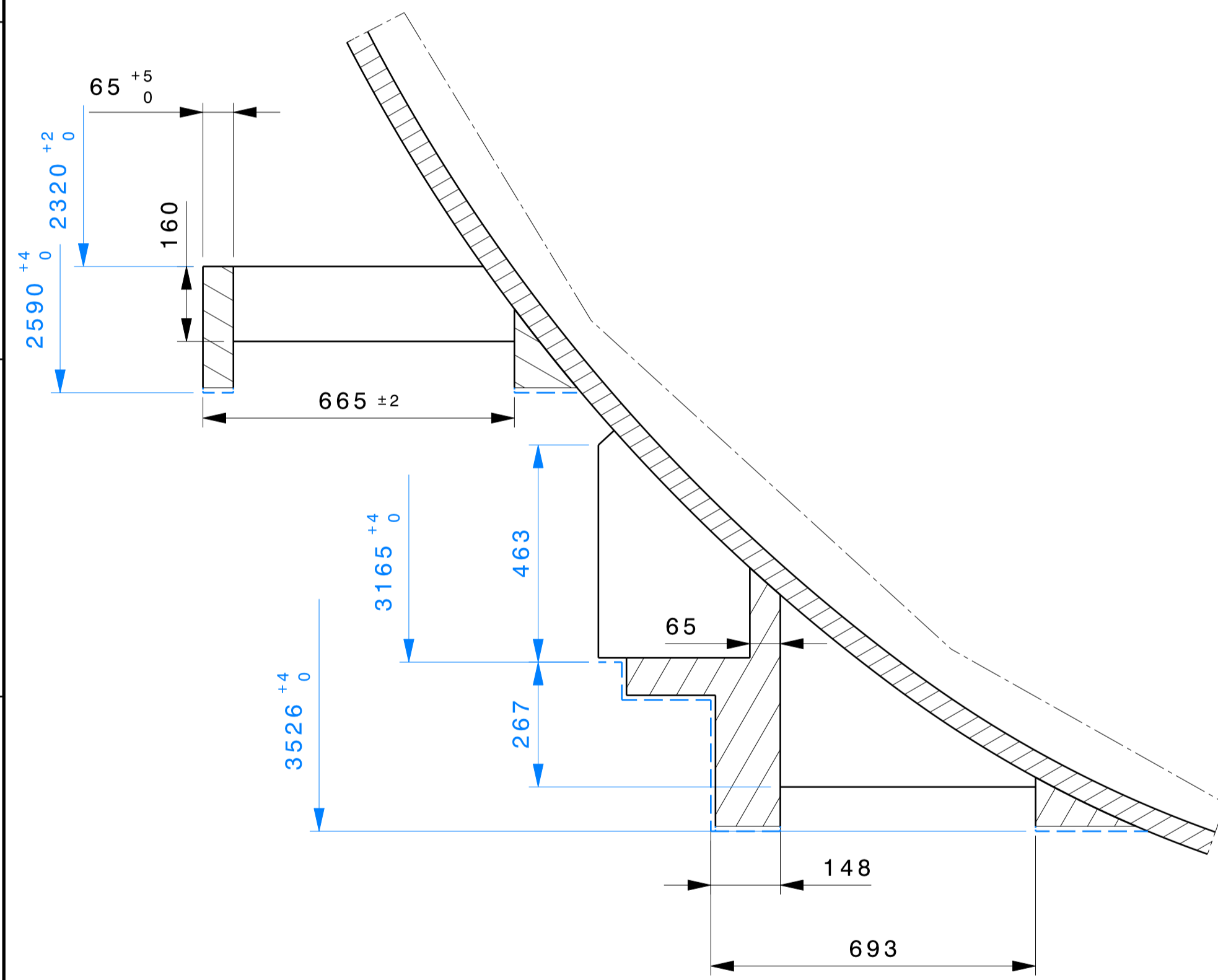

Detail D
Scale: 1:10

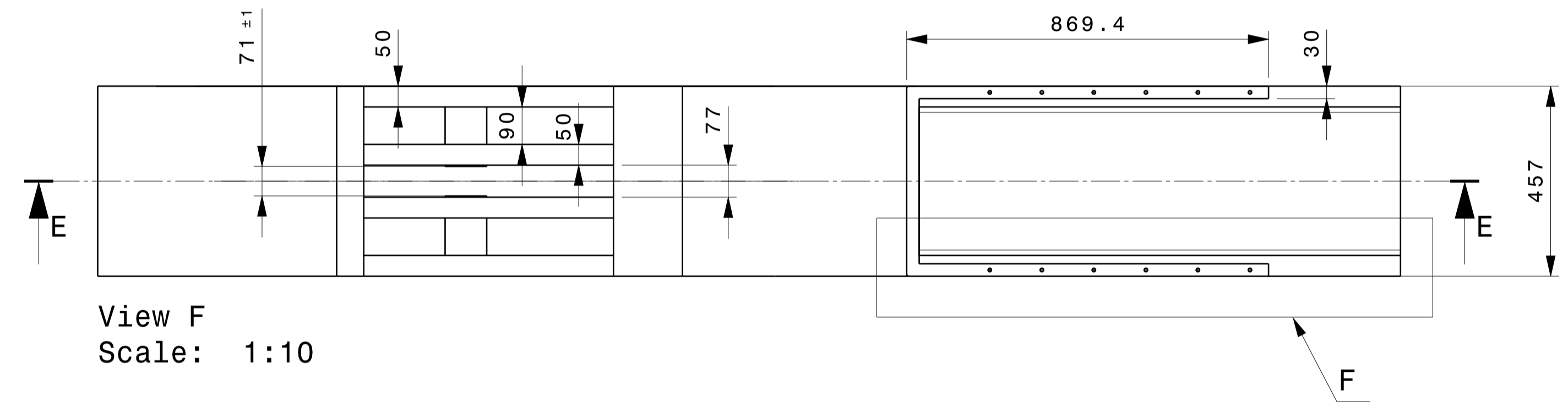

View F
Scale: 1:10

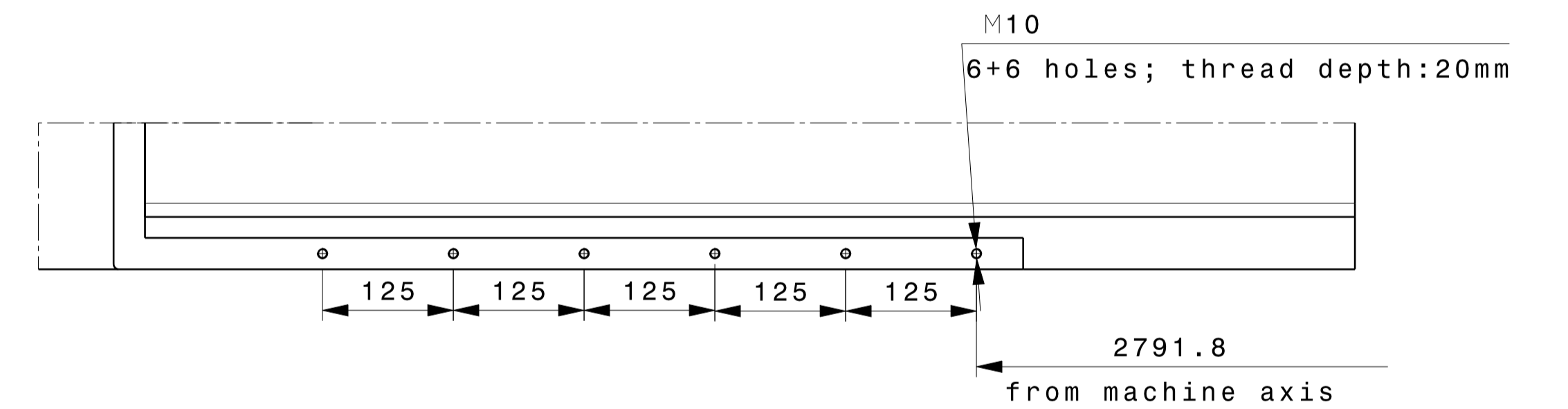

Detail F

- Note:
- DIN ISO 2768-1 & 2768-2 general medium tolerance class for all machining unless otherwise specified
 - For dimension A see drawing 010301 503002
 - For dimension C see drawing 010301 503002
 - X1, X2, X3, X4, X5 are the centre points of the radii
 - For machining of all inner surfaces radii must blend
 - APPLY ROUGHNESS Ra 3.2 UNLESS OTHERWISE SPECIFIED

DRAWING FOR ASG-SUPERCONDUCTOR

FOR CONTRACT				ref. to 3D CatProduct: 010301-203003			
CONFIDENTIAL UNLESS AUTHORISED <small>The information on this drawing is confidential under the terms of the BA agreement. This information shall not be transmitted to anyone who is not authorised to receive it.</small>		APPROVED BY A.CUCCHIARO		ENEA Italy-Frascati Research Centre		CUSTOMER: Fusion-for-Energy	
REV DATE 18-06-2012		CHECKED BY G.M.POLLI		DRAWING TITLE Curved Leg Outboard Toroidal Field Coil			
FIRST ISSUE DATE 10-11-2011		CONTROLLED BY G.M.POLLI		CODE ENEA ID: DD-JT60TF-NCO			
SHEET SIZE A1	FIRST ANGLE PROJECTION	WBS LEVELS 3	010301	Drawing Number 503003	SHEET 02	REVISION 02	MATURITY

DIMENSIONS RELATE TO ROOM TEMPERATURE (293K)

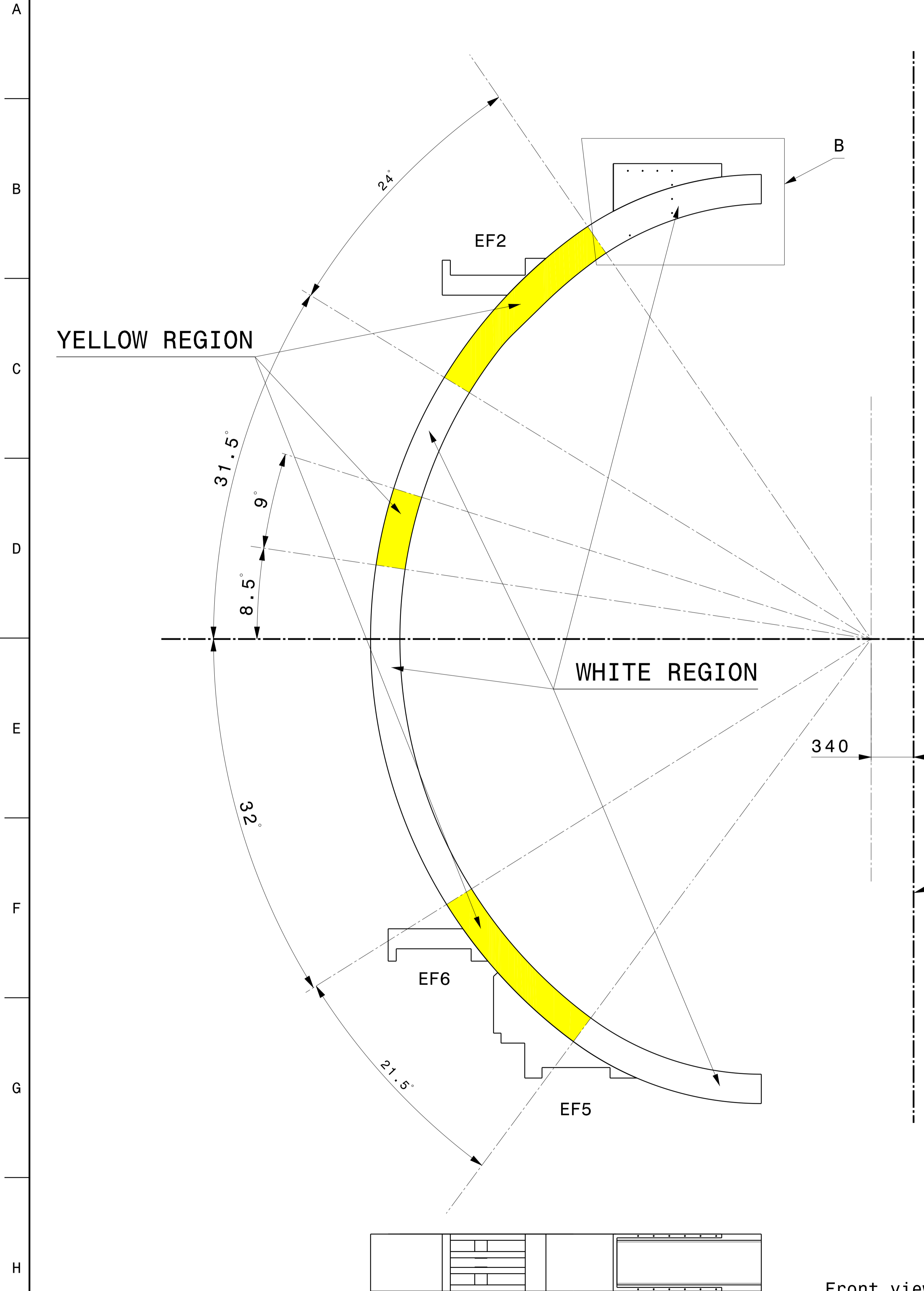

Front view
Scale: 1:20

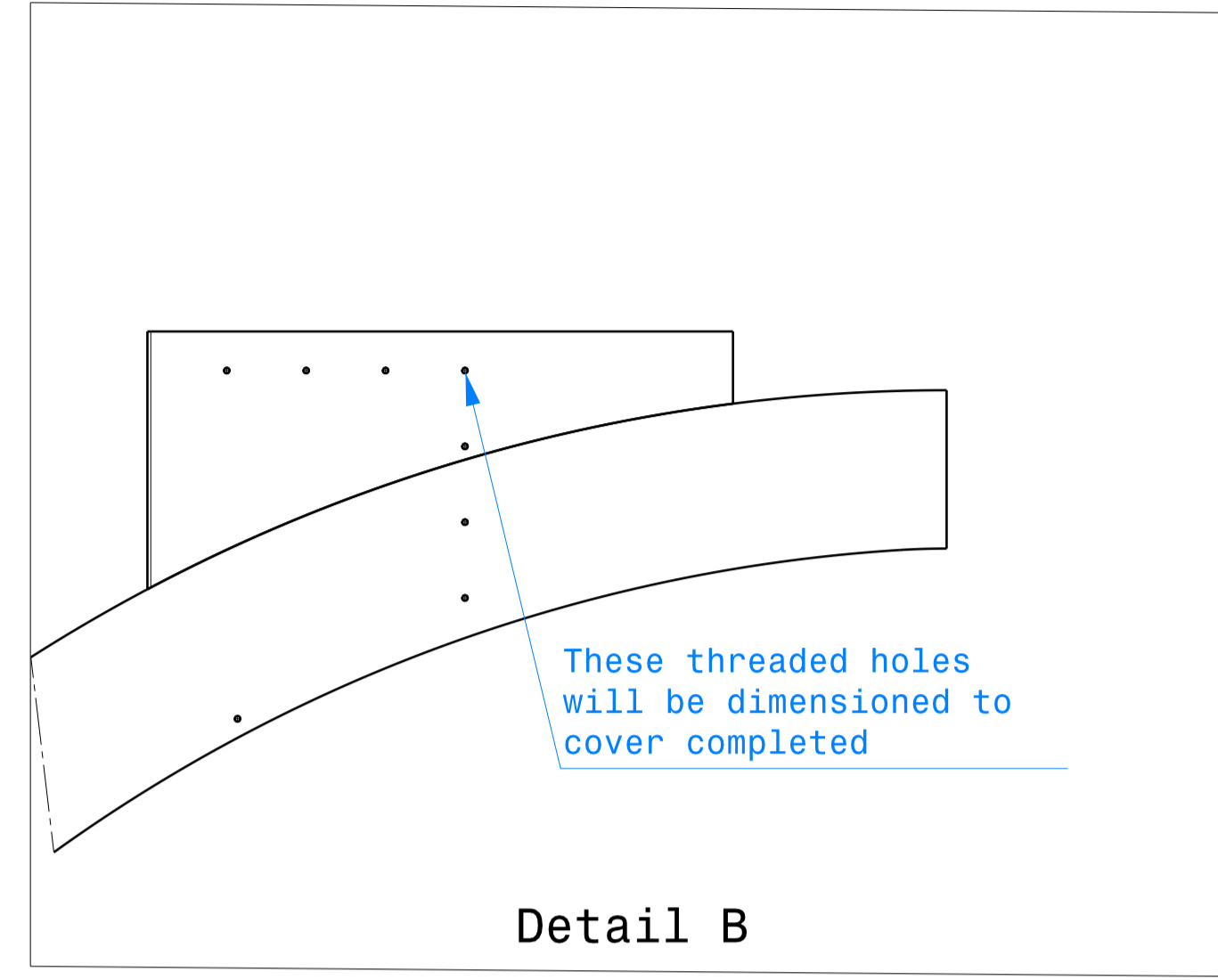

Bottom view
Scale: 1:20

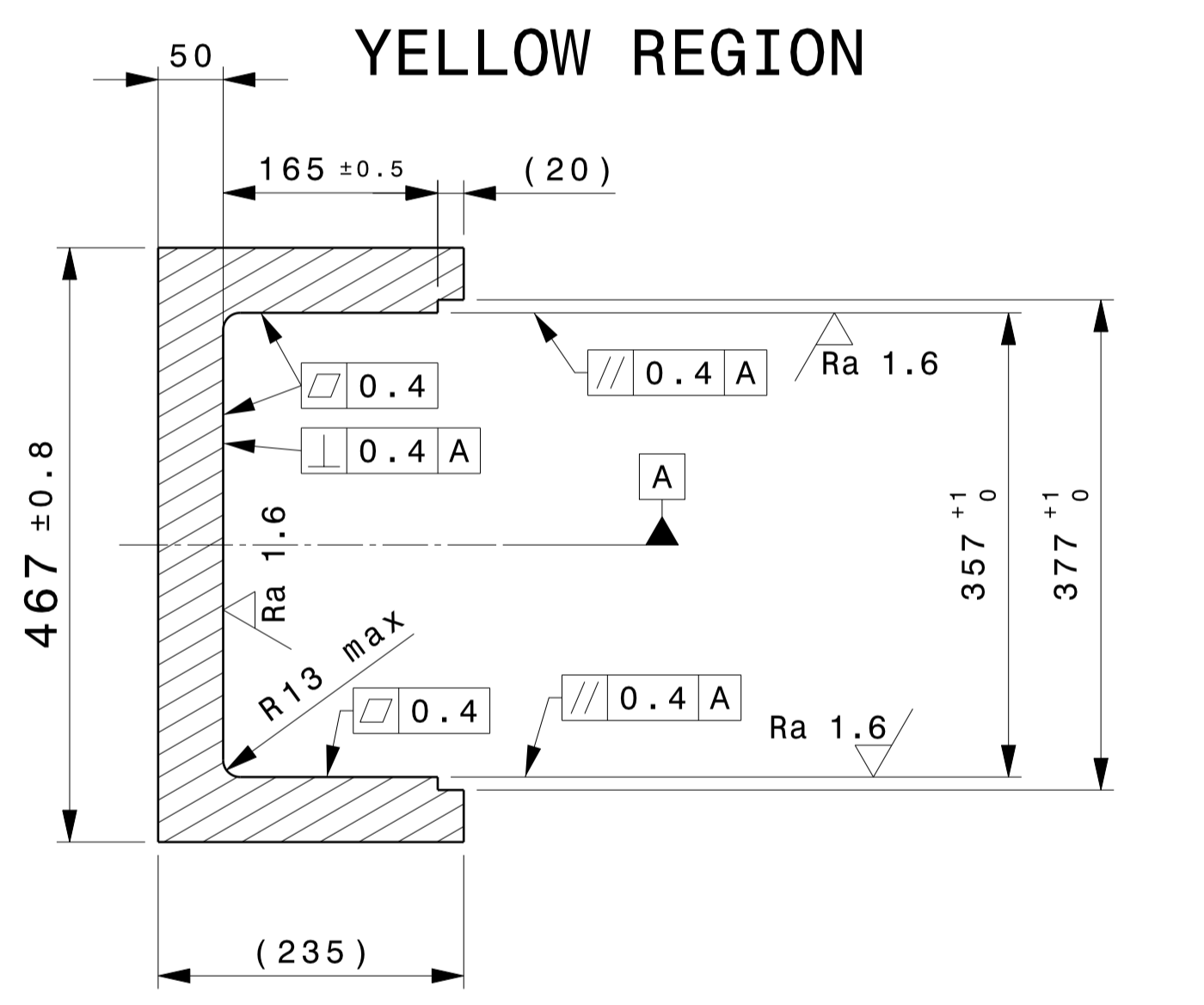
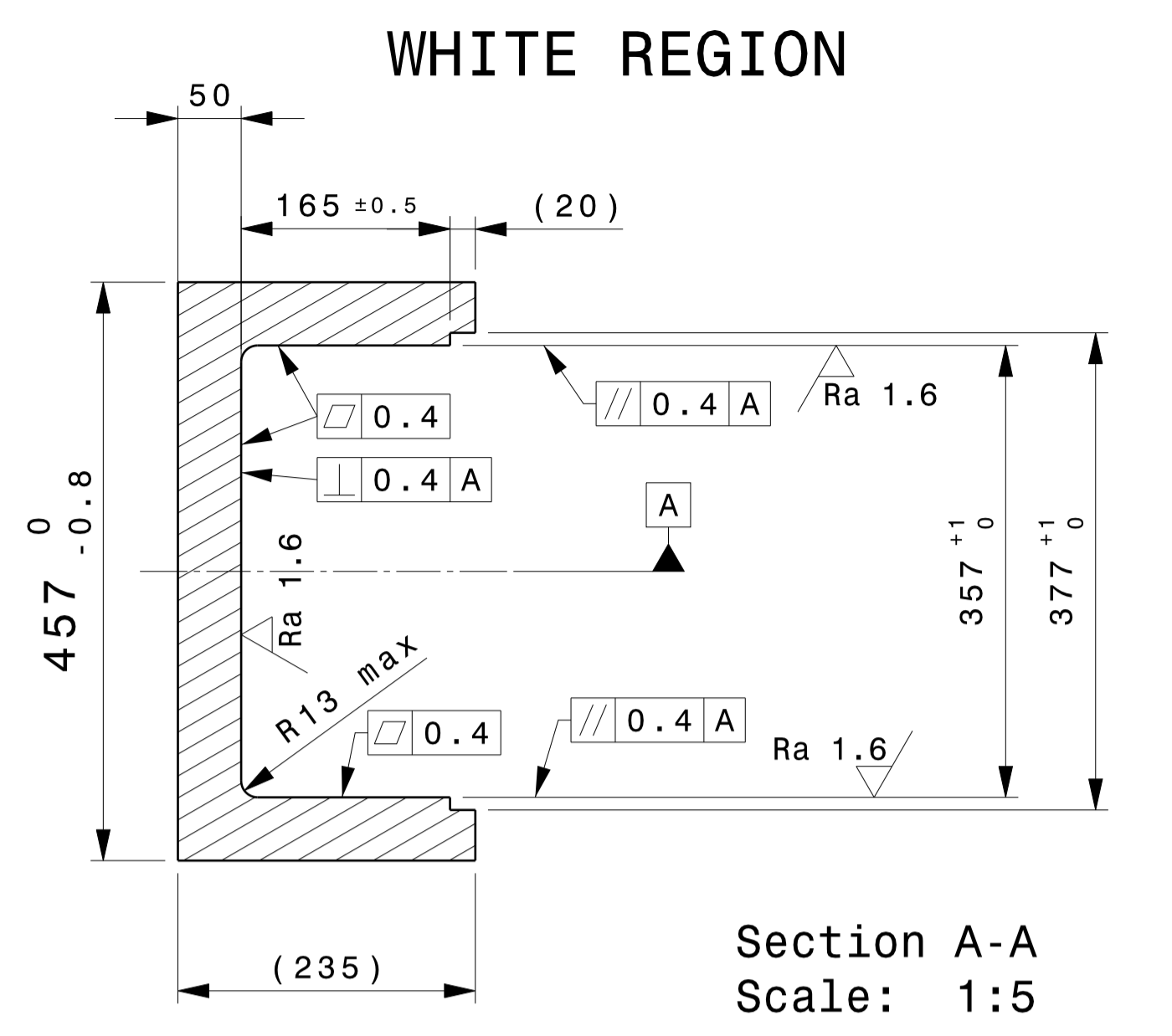

NOTE:
-DIN ISO 2768-1 & 2768-2 general medium tolerance class for all machining unless otherwise specified
-APPLY ROUGHNESS Ra 3.2 UNLESS OTHERWISE SPECIFIED

DRAWING FOR ASG-SUPERCONDUCTOR

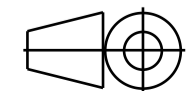
FOR CONTRACT		ref. to 3D CatProduct: 010301-203003	
CONFIDENTIAL UNLESS AUTHORISED <small>The information on this drawing is confidential under the terms of the BA agreement. This information shall not be transmitted to anyone who is not authorised to receive it.</small>	APPROVED BY A. CUCCHIARO	 Fusion Italy-Frascati Research Centre	CUSTOMER: Fusion-for-Energy
	REVIEWED BY		DRAWING TITLE Curved Leg Outboard Toroidal Field Coil
REV DATE 18-06-2012	CHECKED BY	CONTROLLED BY G.M. POLLI	CODE ENEA ID: DD-JT60TF-NCO
FIRST ISSUE DATE 10-11-2011	SCALE NTS	DRAWN BY G. BROLATTI	
SHEET SIZE A1	FIRST ANGLE PROJECTION 	WBS LEVELS 3 LEVELS	010301
		Drawing Number 503003	SHEET 03
			REVISION 02
			MATURITY

DIMENSIONS RELATE TO ROOM TEMPERATURE (293K)

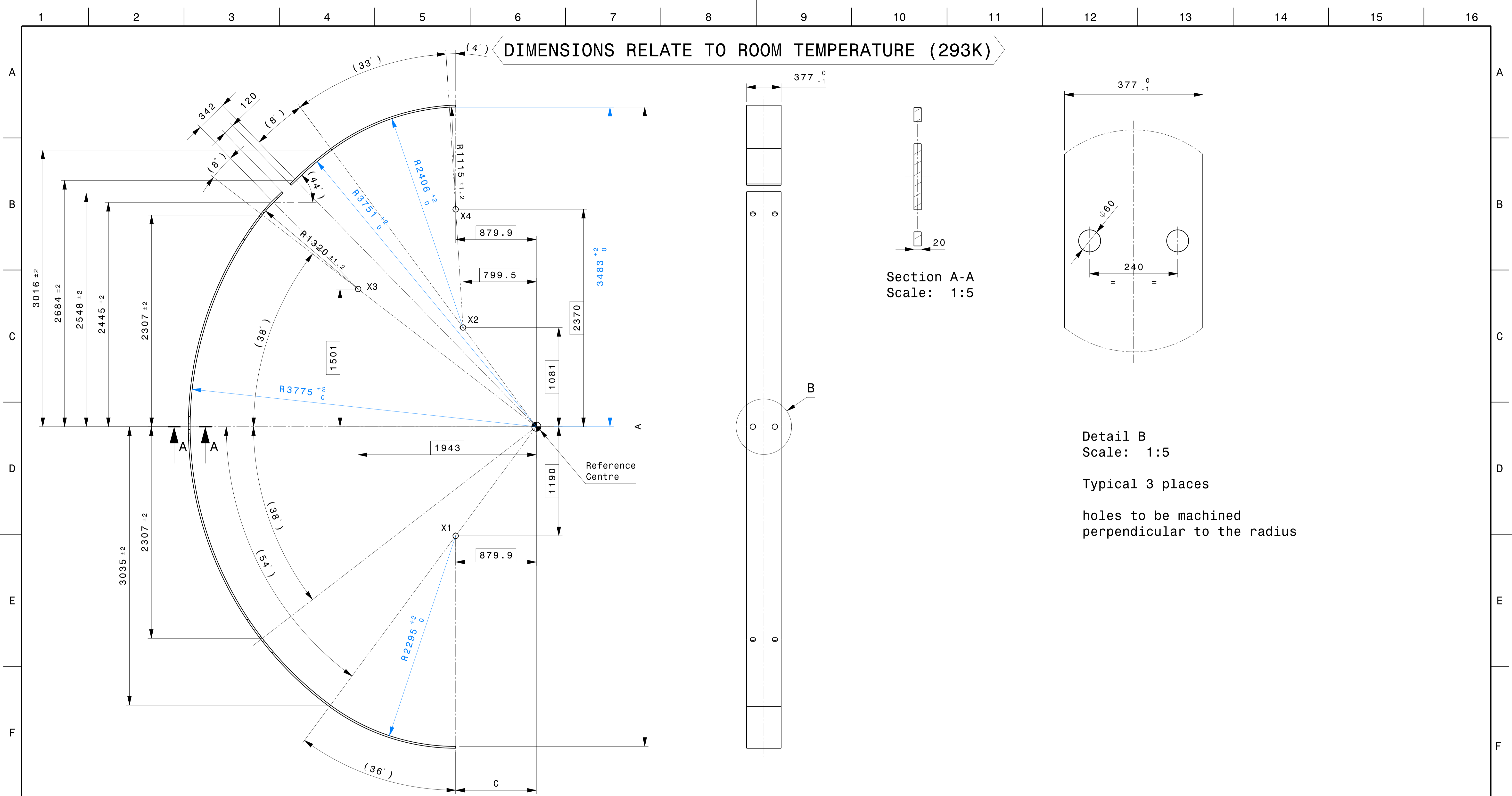

Front view
Scale: 1:20

Left view
Scale: 1:20

Section A-A
Scale: 1:5

Detail B
Scale: 1:5
Typical 3 places
holes to be machined
perpendicular to the radius

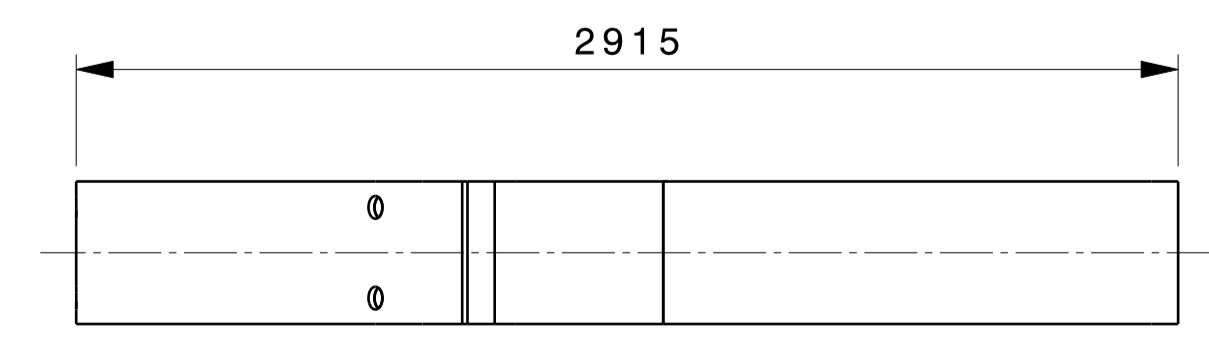

Top view
Scale: 1:20

Note:
-DIN ISO 2768-1 & 2768-2 general medium tolerance class for all machining unless otherwise specified
-For dimension A see drawing 010301 503002
-For dimension C see drawing 010301 503002
-X1, X2, X3, X4 are the centre points of the radii
-For machining of all inner surfaces radii must blend
-APPLY ROUGHNESS Ra 3.2 UNLESS OTHERWISE SPECIFIED

DRAWING FOR ASG-SUPERCONDUCTOR

FOR CONTRACT		ref. to 3D CatProduct: 010301-203004	
CONFIDENTIAL UNLESS AUTHORISED <small>The information on this drawing is confidential under the terms of the BA agreement. This information shall not be transmitted to anyone who is not authorised to receive it.</small>	APPROVED BY A. CUCCHIARO	Fusión Italy-Frascati Research Centre	CUSTOMER: Fusion-for-Energy
	REVIEWED BY		DRAWING TITLE Curved Leg Inboard Toroidal Field Coil
REV DATE 18-06-2012	CHECKED BY	CODE ENEA ID: DD-JT60TF-NCO	
FIRST ISSUE DATE 10-11-2011	SCALE NTS	CONTROLLED BY G.M.POLLI	
SHEET SIZE A1	FIRST ANGLE PROJECTION	DRAWN BY G. BROLATTI	
WBS 3 LEVELS	010301	Drawing Number 503004	SHEET 01
			REVISION 03
			MATURITY

DIMENSIONS RELATE TO ROOM TEMPERATURE (293K)

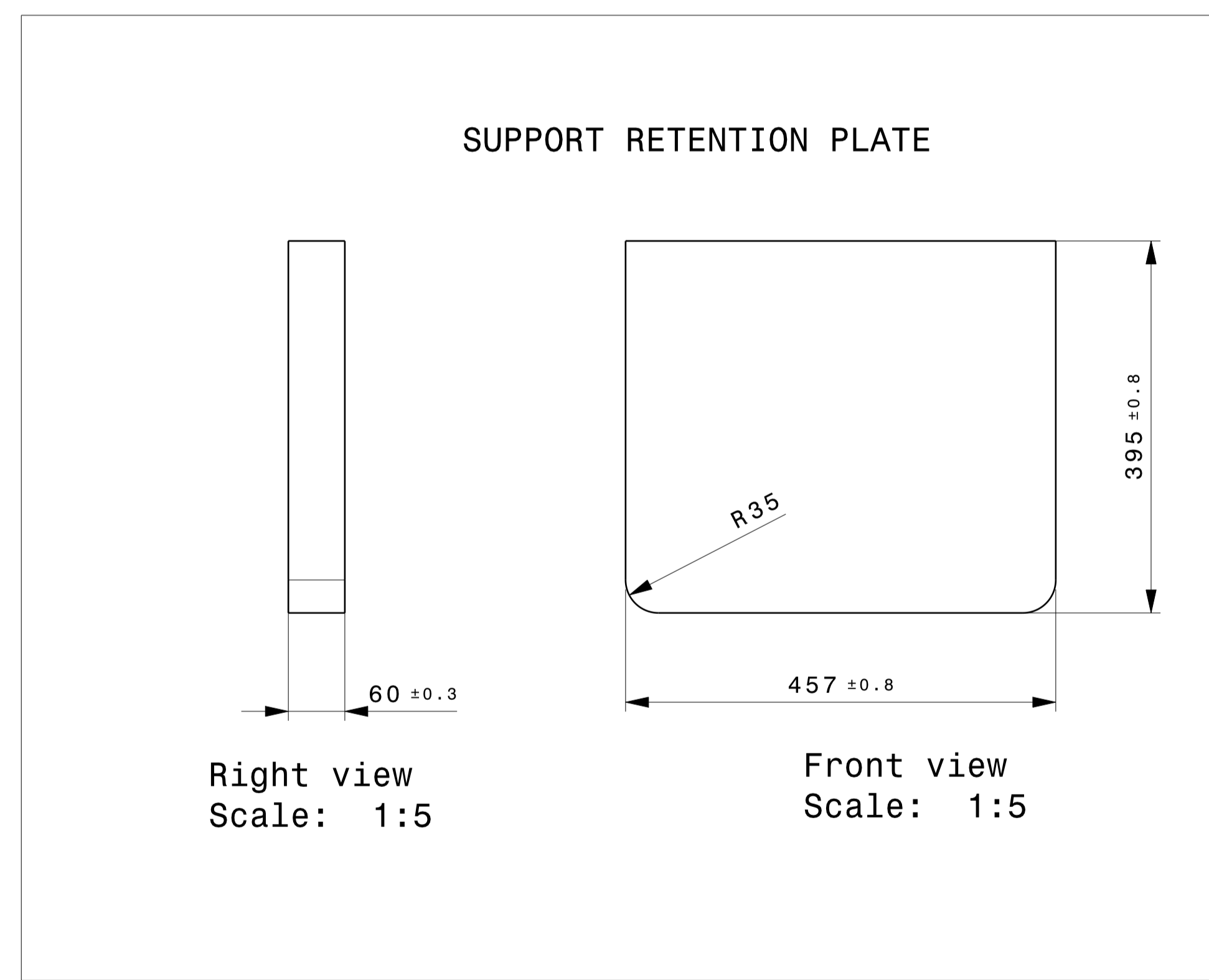
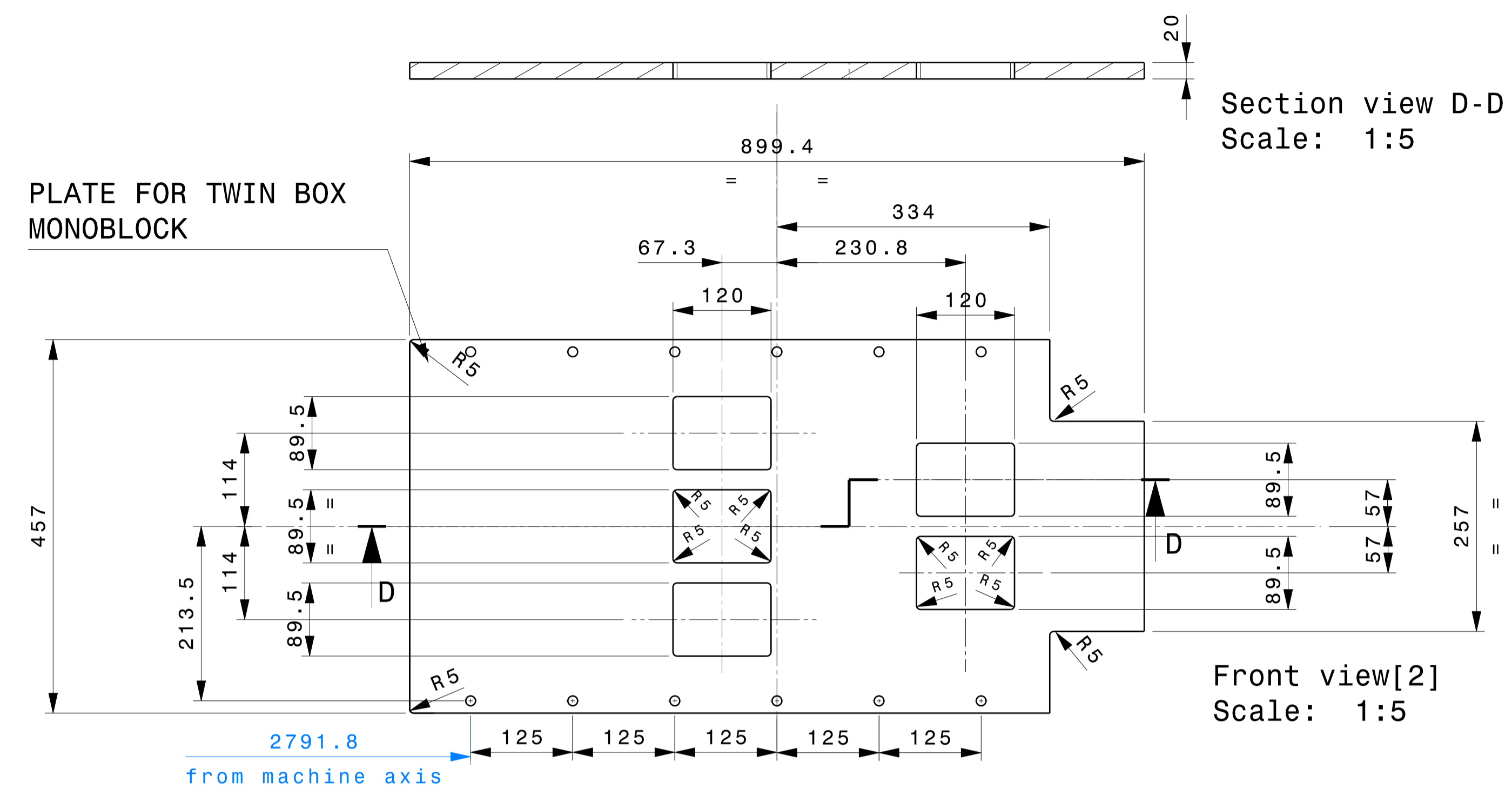
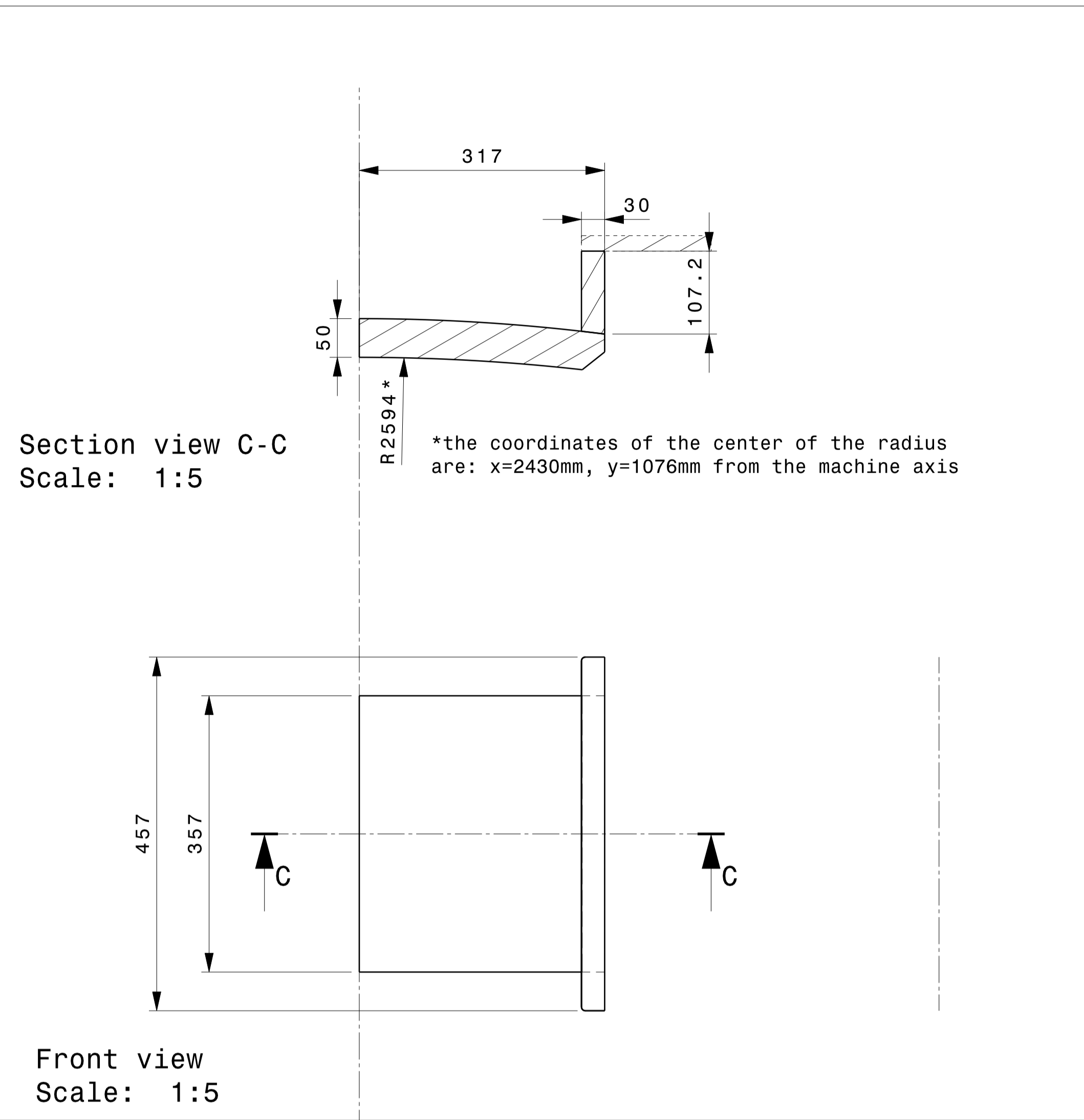

Note:
 -DIN ISO 2768-1 & 2768-2 general medium tolerance class for all machining unless otherwise specified
 -APPLY ROUGHNESS Ra 3.2 UNLESS OTHERWISE SPECIFIED

DRAWING FOR ASG-SUPERCONDUCTOR

FOR CONTRACT		ref. to 3D CatProduct: 010301-203005	
CONFIDENTIAL UNLESS AUTHORISED The information on this drawing is confidential under the terms of the BA agreement. This information shall not be transmitted to anyone who is not authorised to receive it.	APPROVED BY A.CUCCHIARO	 Fusion Italy-Frascati Research Centre	CUSTOMER: Fusion-for-Energy
	REVIEWED BY		DRAWING TITLE Miscellaneous Components Toroidal Field Coil
REV DATE 18-06-2012	CHECKED BY	CONTROLLED BY G.M.POLLI	CODE ENEA ID: DD-JT60TF-NCO
FIRST ISSUE DATE 10-11-2011	SCALE NTS	DRAWN BY G. BROLATTI	
SHEET SIZE A1	FIRST ANGLE PROJECTION	WBS LEVELS 3	010301
		Drawing Number 503005	SHEET 01
			REVISION 02
			MATURITY

DIMENSIONS RELATE TO ROOM TEMPERATURE (293K)

Section cut C-C
Scale: 1:2

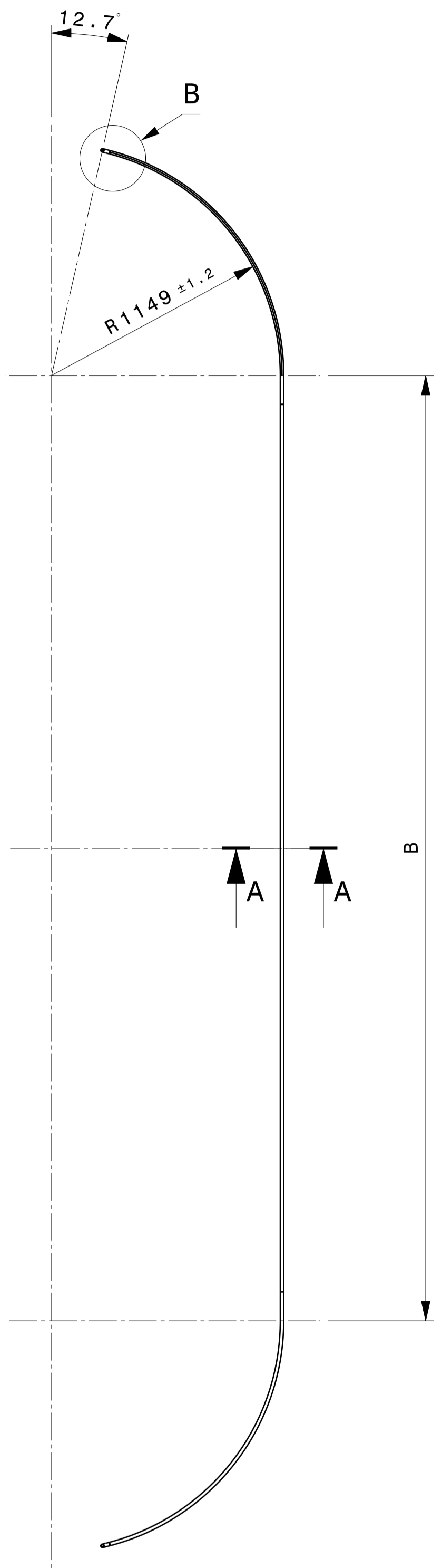

Front view
Scale: 1:20

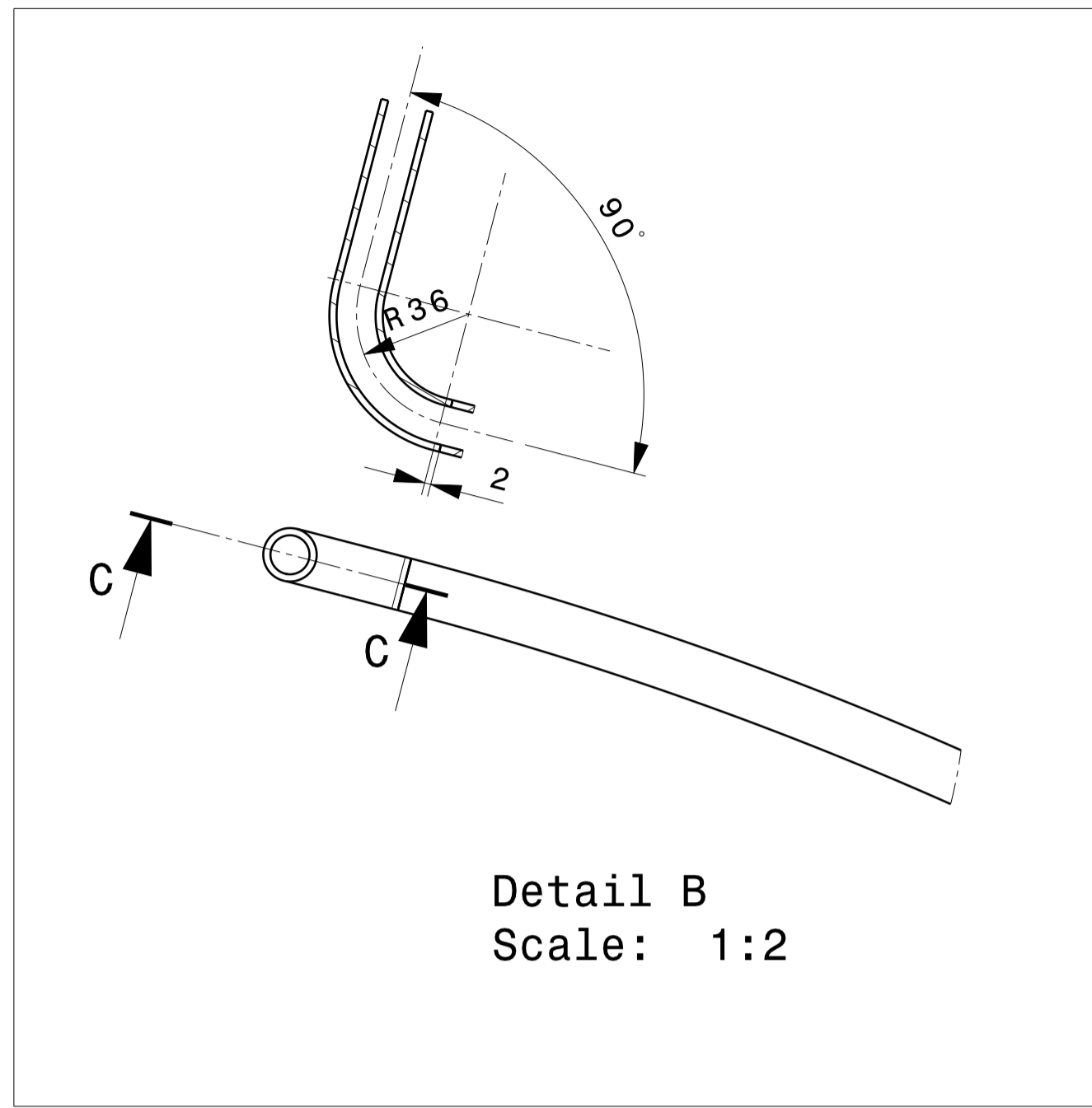

Detail B
Scale: 1:2

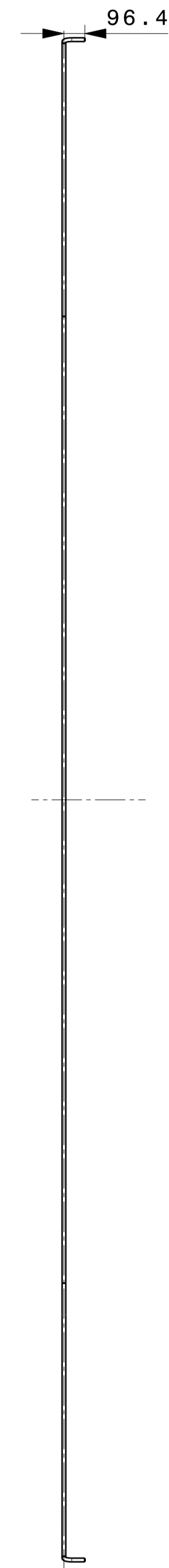

Left view
Scale: 1:20

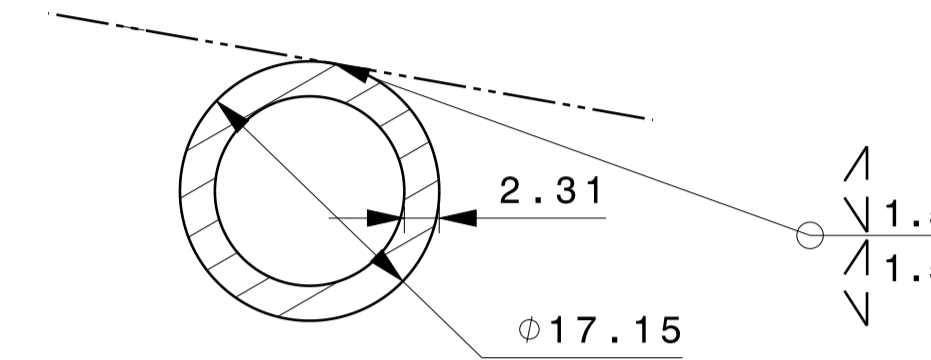

Section A-A
Scale: 2:1

reinforced butt weld 1.5mm

Note:

- DIN ISO 2768-1 & 2768-2 general medium tolerance class for all machining unless otherwise specified
- For dimension B see drawing 010301 503002
- No trapped air volume is allowed between the cooling channel and the coil casing
- total length of the tube about 8m**
- APPLY ROUGHNESS Ra 3.2 UNLESS OTHERWISE SPECIFIED

DRAWING FOR ASG-SUPERCONDUCTOR

FOR CONTRACT				ref. to 3D CatProduct: 010301-203006					
CONFIDENTIAL UNLESS AUTHORISED The information on this drawing is confidential under the terms of the BA agreement. This information shall not be transmitted to anyone who is not authorised to receive it.				APPROVED BY A. CUCCHIARO		 Fusion Italy-Frascati Research Centre		CUSTOMER: Fusion-for-Energy	
				REVIEWED BY				DRAWING TITLE Inner He Cooling Layout Toroidal Field Coil	
REV DATE 18-06-2012		CHECKED BY		CONTROLLED BY G.M. POLLI		CODE ENEA ID: DD-JT60TF-NCO			
FIRST ISSUE DATE 10-11-2011		SCALE NTS		DRAWN BY G. BROLATTI					
SHEET SIZE A1		FIRST ANGLE PROJECTION		WBS LEVELS 010301		Drawing Number 503006		SHEET REVISION MATURITY 01 02	

DIMENSIONS RELATE TO ROOM TEMPERATURE (293K)

-the closure shown has only an indicative purpose, the final design of the bevel will be forwarded by ENEA on the base of the specification of the coil suppliers

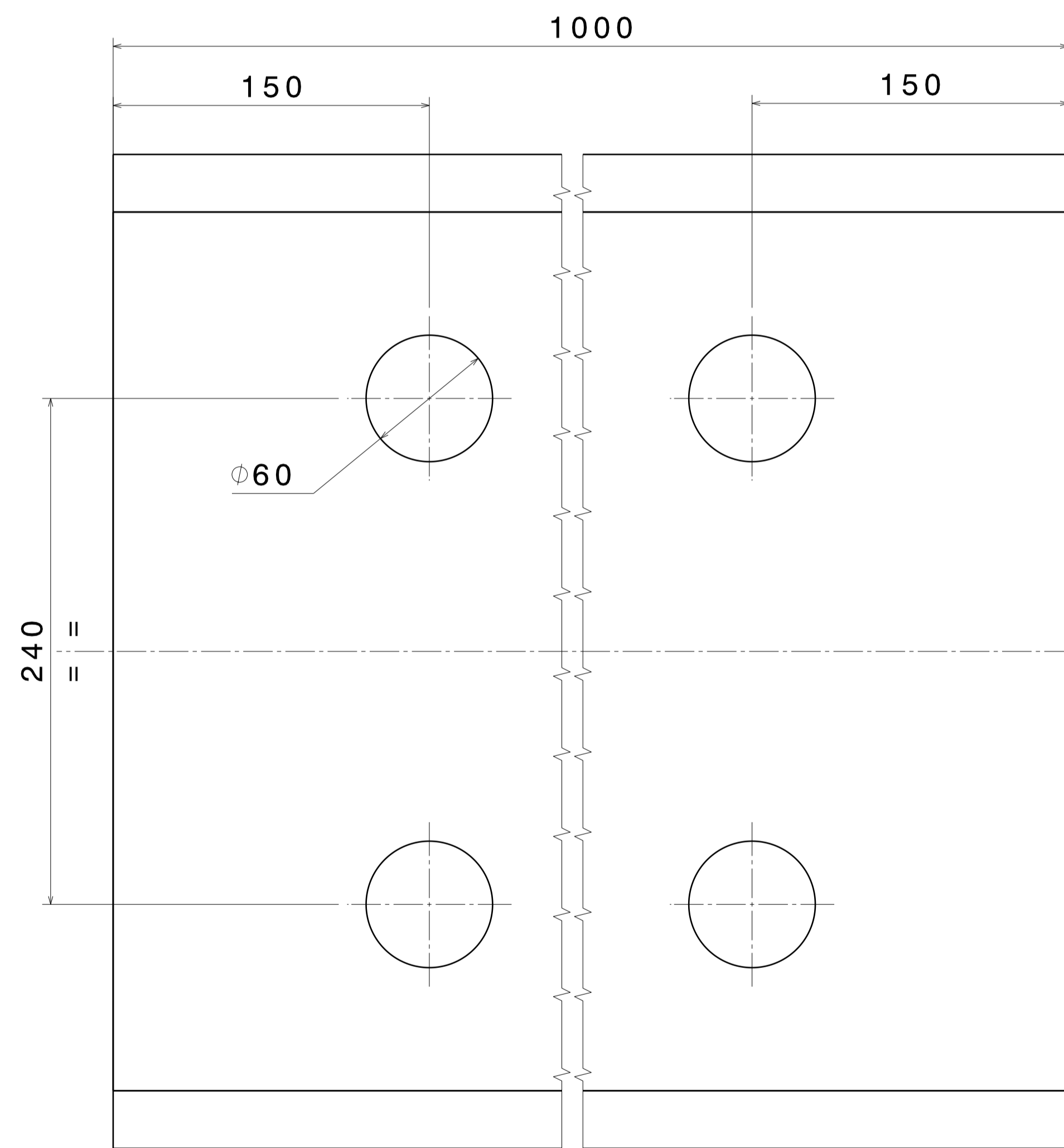
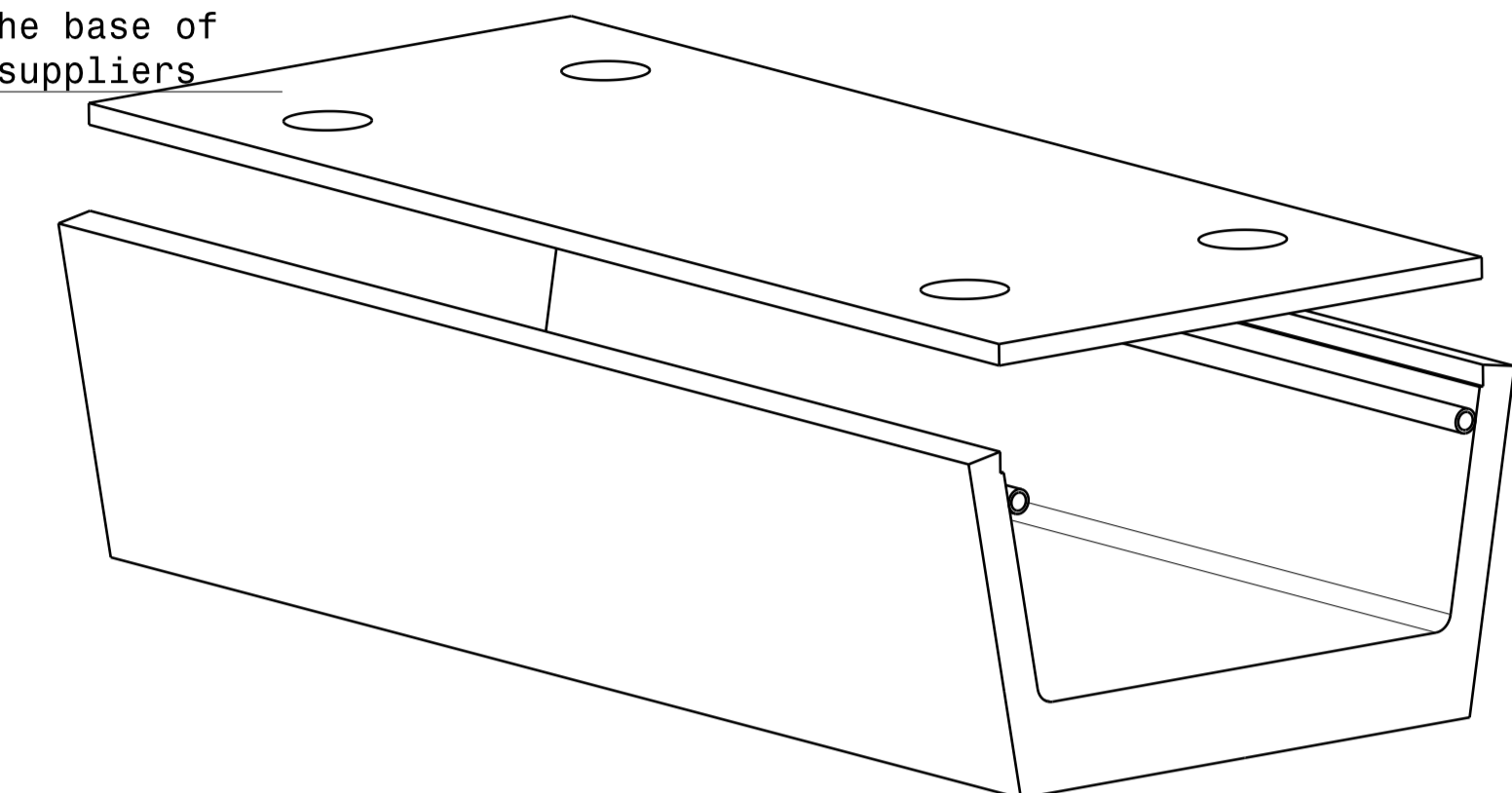
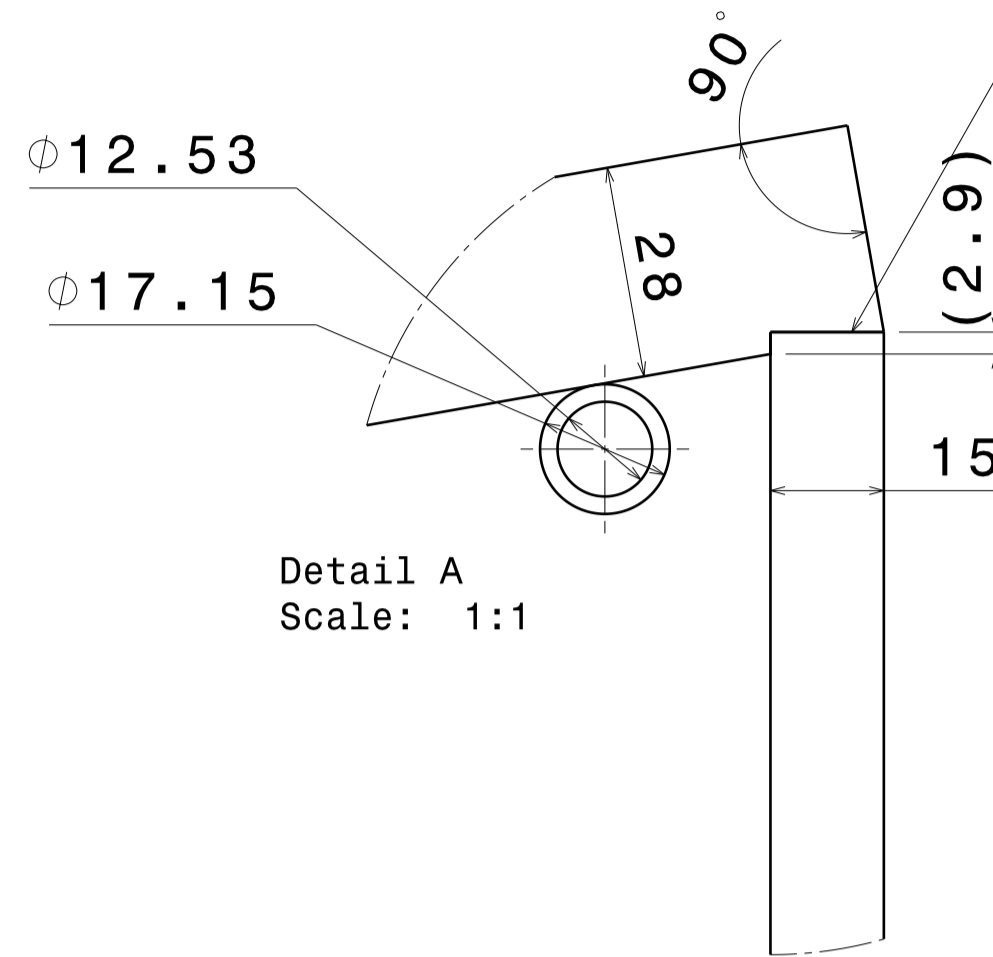

Right view
Scale: 1:2

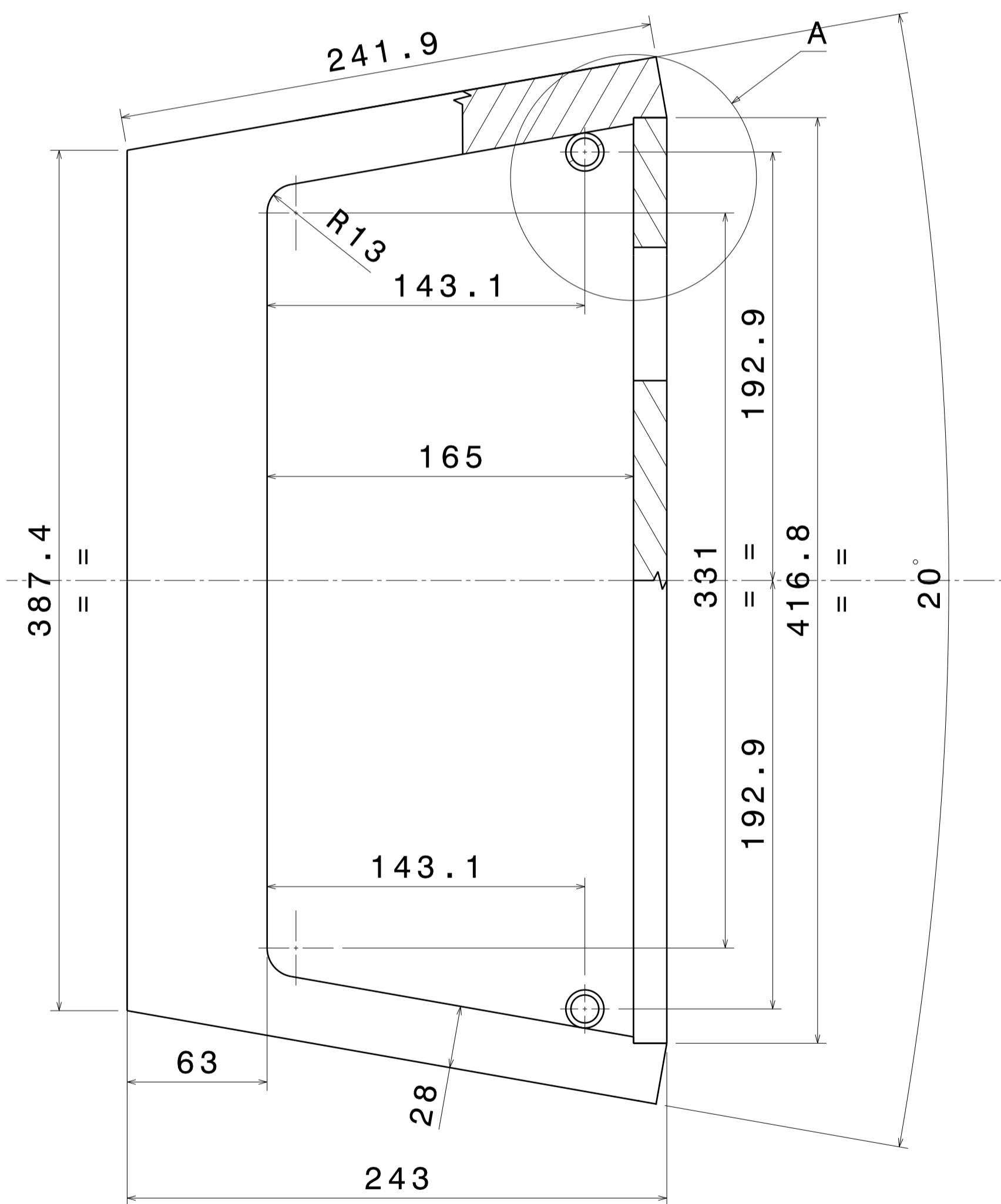

Front view
Scale: 1:2

NOTE:

-DIN ISO 2768-1 & 2768-2 general medium tolerance class for all machining unless otherwise specified

-APPLY ROUGHNESS Ra 3.2 UNLESS OTHERWISE SPECIFIED

DRAWING FOR ALSTOM

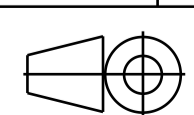
FOR CONTRACT				Ref to 3D CatProduct: 010301 203007				
<small>CONFIDENTIAL UNLESS AUTHORISED The information on this drawing is confidential under the terms of the BA agreement. This information shall not be transmitted to anyone who is not authorised to receive it.</small>				APPROVED BY A. CUCCHIARO		 Fusion <small>Italy-Frascati Research Centre</small>		CUSTOMER: Fusion-for-Energy
REVIEWED BY				CHECKED BY		DRAWING TITLE MOCK UP: STRAIGHT BEAM 1 METRE LONG OF THE CASING (LONGITUDINAL WELDING)		
REV DATE 29-05-2012				CONTROLLED BY G.M. POLLI		CODE ENEA ID: DD-JT60TF-NCO		
FIRST ISSUE DATE 27/07/2011		SCALE NTS		DRAWN BY G. BROLATTI				
SHEET SIZE A1	FIRST ANGLE PROJECTION 	WBS LEVELS 3	010301	Drawing Number 503107	SHEET 01	REVISION 03	MATURITY	

DIMENSIONS RELATE TO ROOM TEMPERATURE (293K)

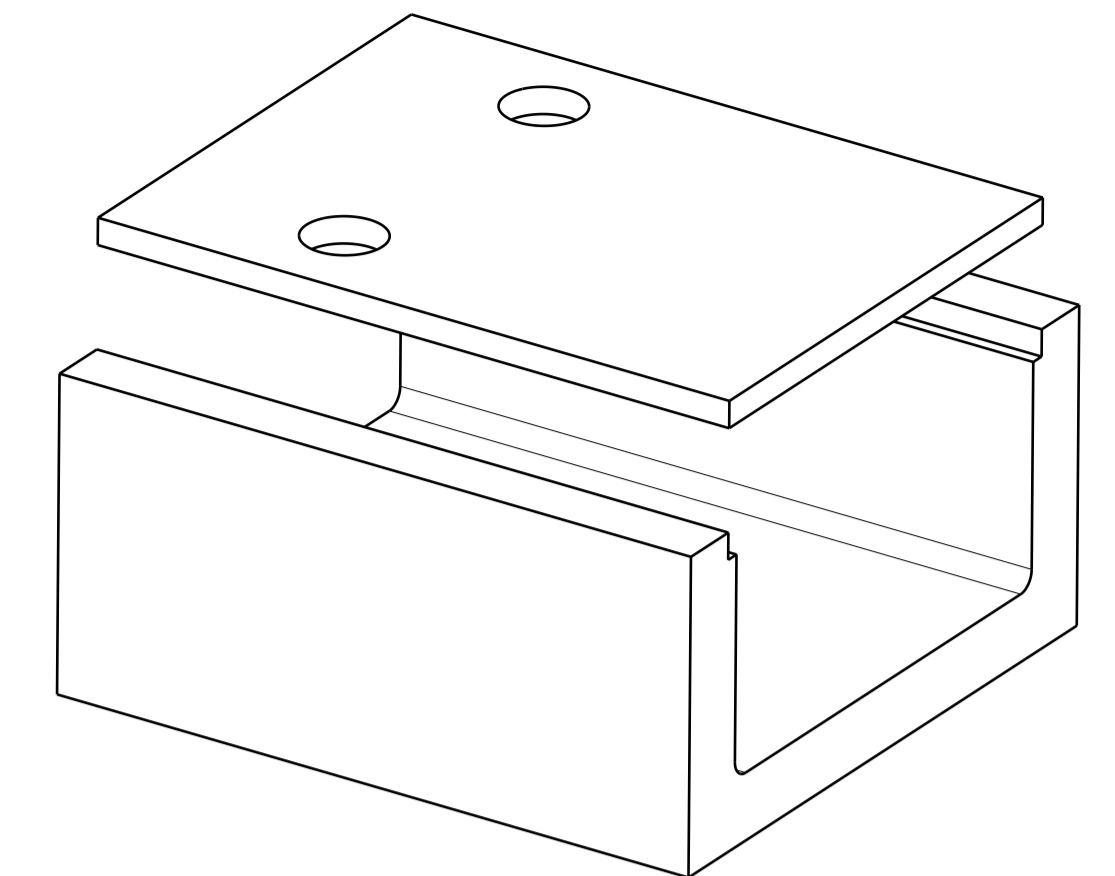

Isometric view

-the closure shown has only an indicative purpose, the final design of the bevel will be forwarded by ENEA on the base of the specification of the coil suppliers

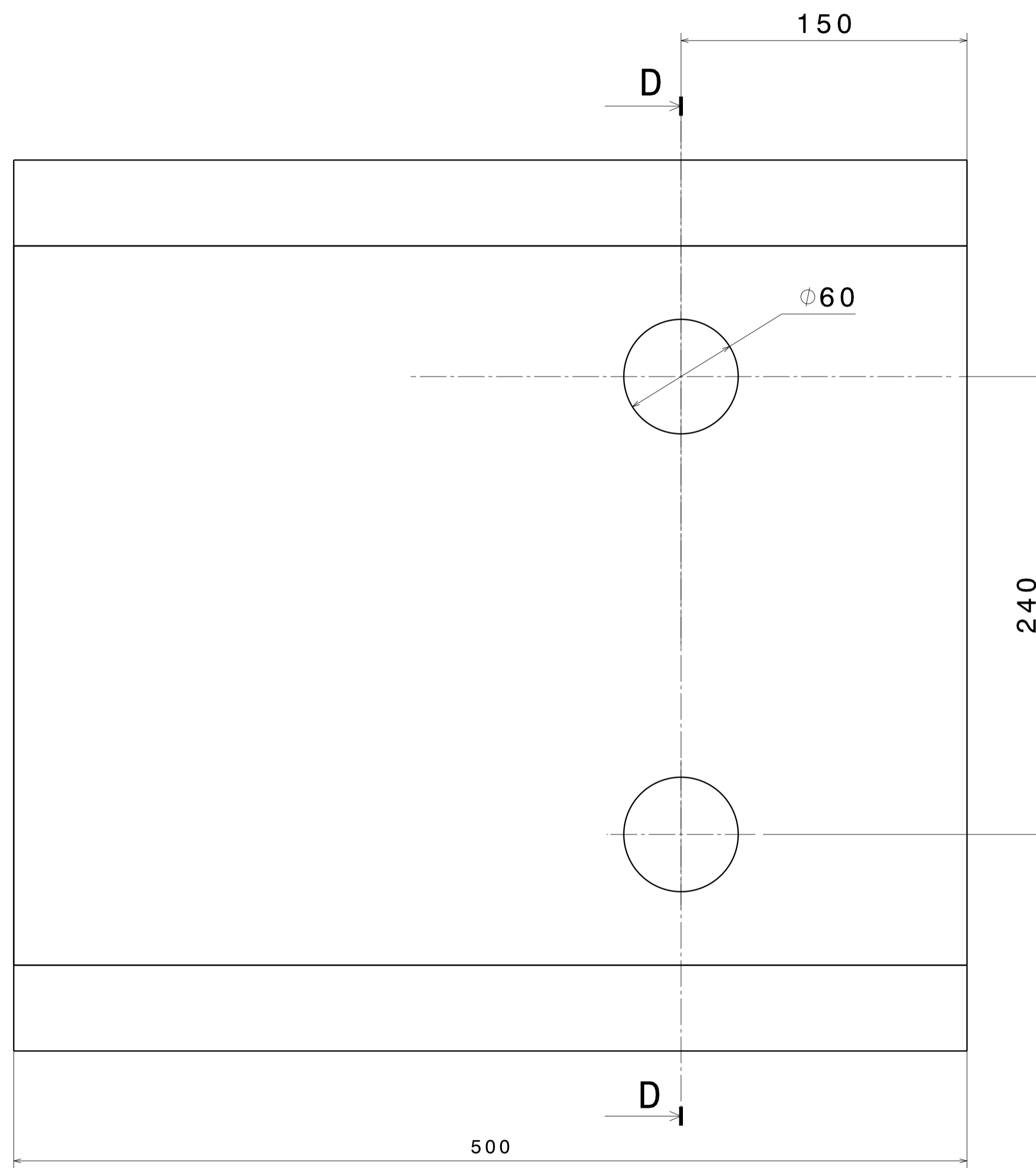

Auxiliary view C
Scale: 1:2

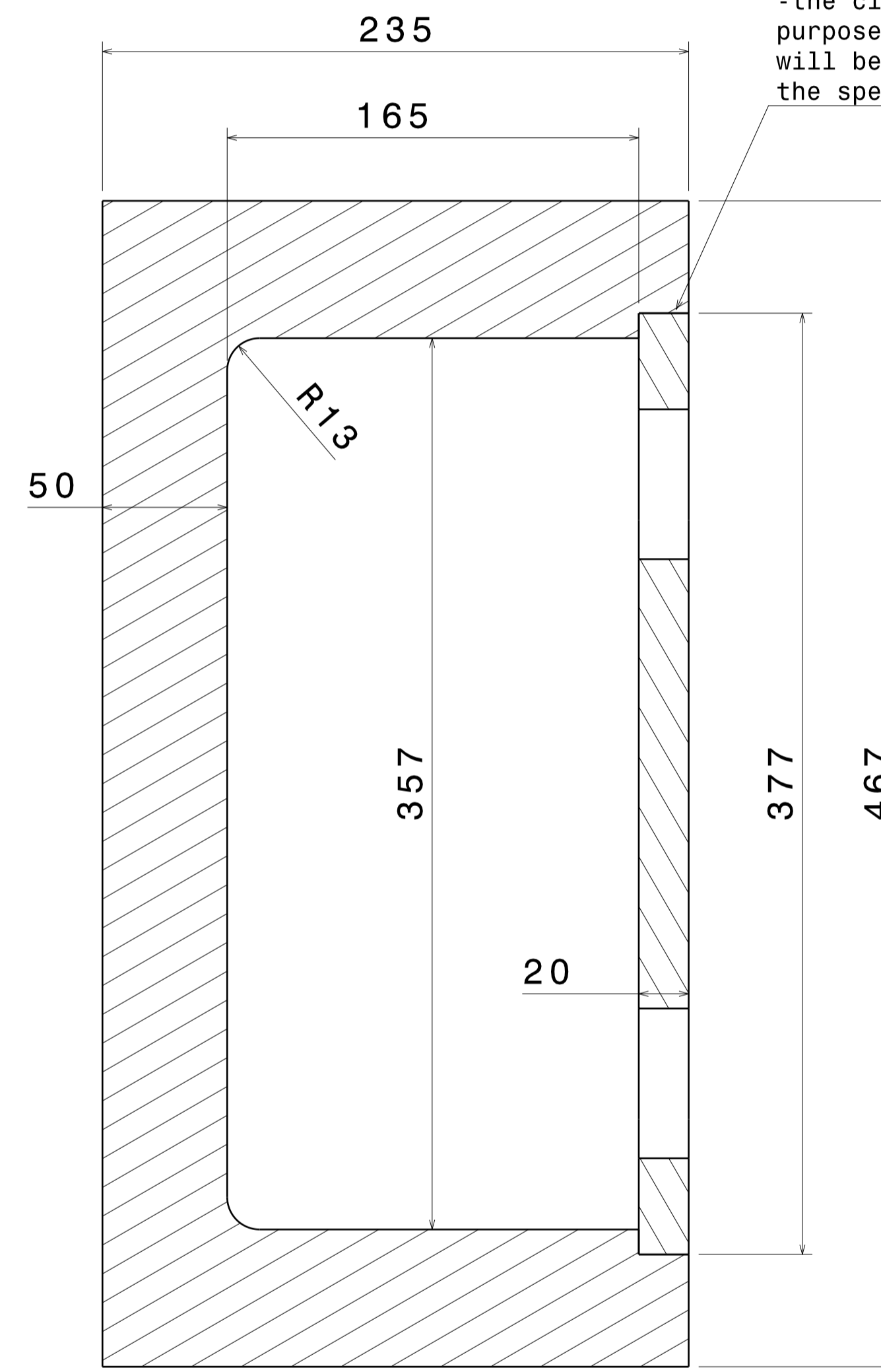

Section view D-D
Scale: 1:2

NOTE:
 -DIN ISO 2768-1 & 2768-2 general medium tolerance class for all machining unless otherwise specified
 -APPLY ROUGHNESS Ra 3.2 UNLESS OTHERWISE SPECIFIED

DRAWING FOR ALSTOM

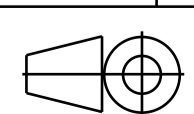
FOR CONTRACT				ref. to 3D CatProduct: 010301-203008				
CONFIDENTIAL UNLESS AUTHORISED <small>The information on this drawing is confidential under the terms of the BA agreement. This information shall not be transmitted to anyone who is not authorised to receive it.</small>		APPROVED BY A. CUCCHIARO		 Fusion <small>Italy-Frascati Research Centre</small>		CUSTOMER: Fusion-for-Energy		
		REVIEWED BY						
REV DATE 29-05-2012		CONTROLLED BY G.M. POLLI		DRAWING TITLE MOCK UP: STRAIGHT SAMPLE 50 CENTIMETRE LONG OF THE CASING				
FIRST ISSUE DATE 27/07/2011		SCALE NTS		DRAWN BY G. BROLATTI		CODE ENEA ID: DD-JT60TF-NCO		
SHEET SIZE A1	FIRST ANGLE PROJECTION		WBS LEVELS 3	010301	Drawing Number 503108	SHEET 01	REVISION 03	MATURITY

DIMENSIONS RELATE TO ROOM TEMPERATURE (293K)

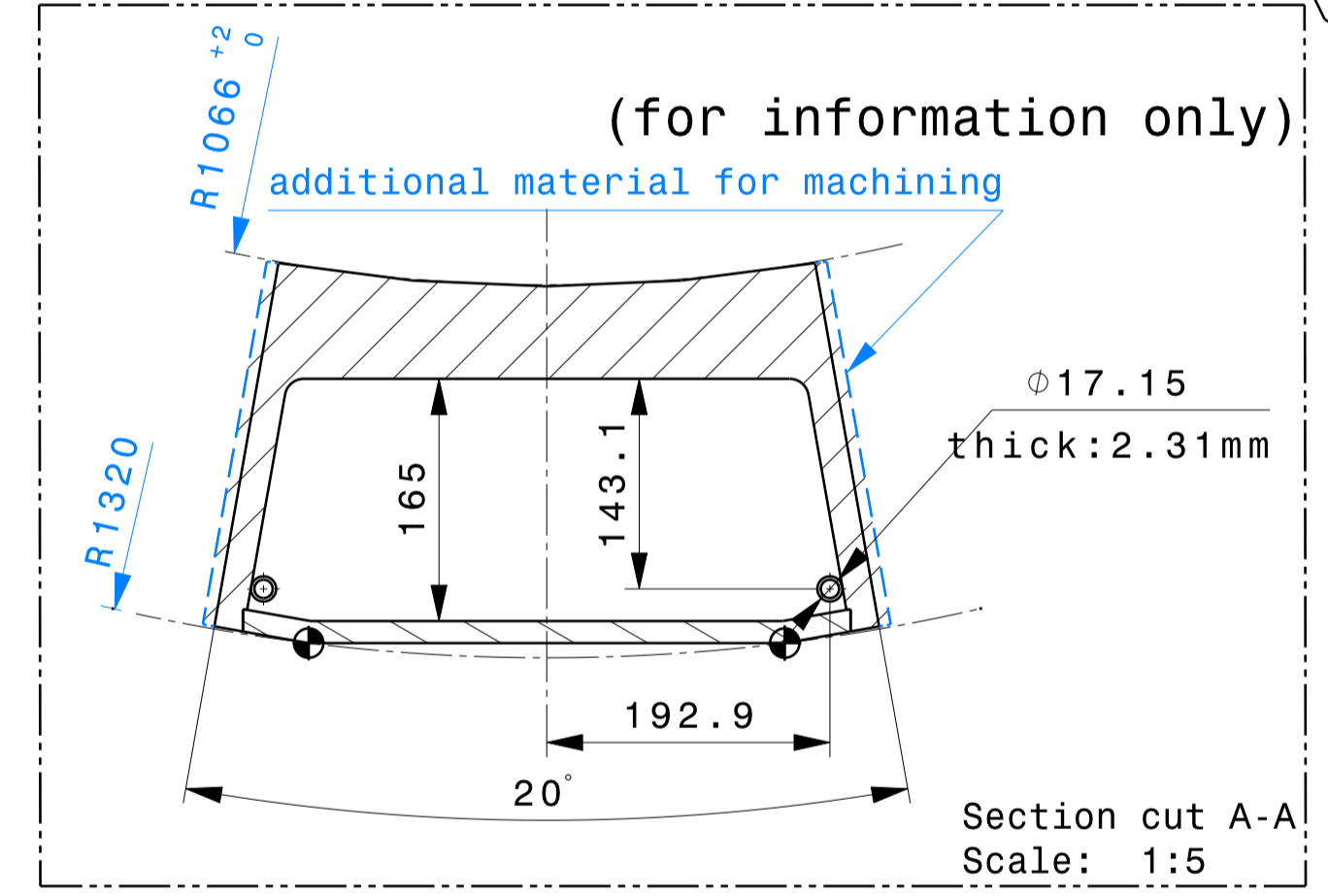
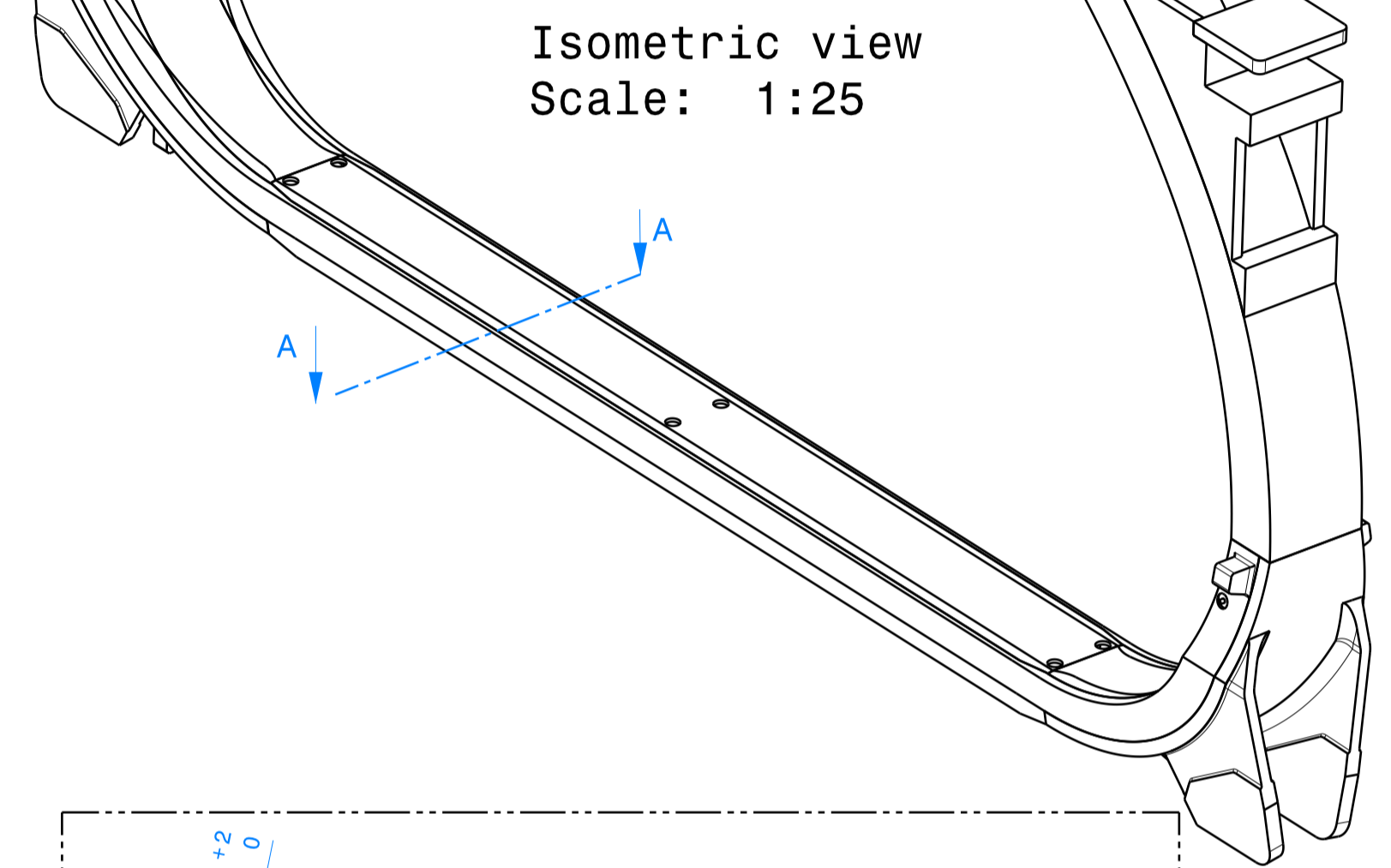
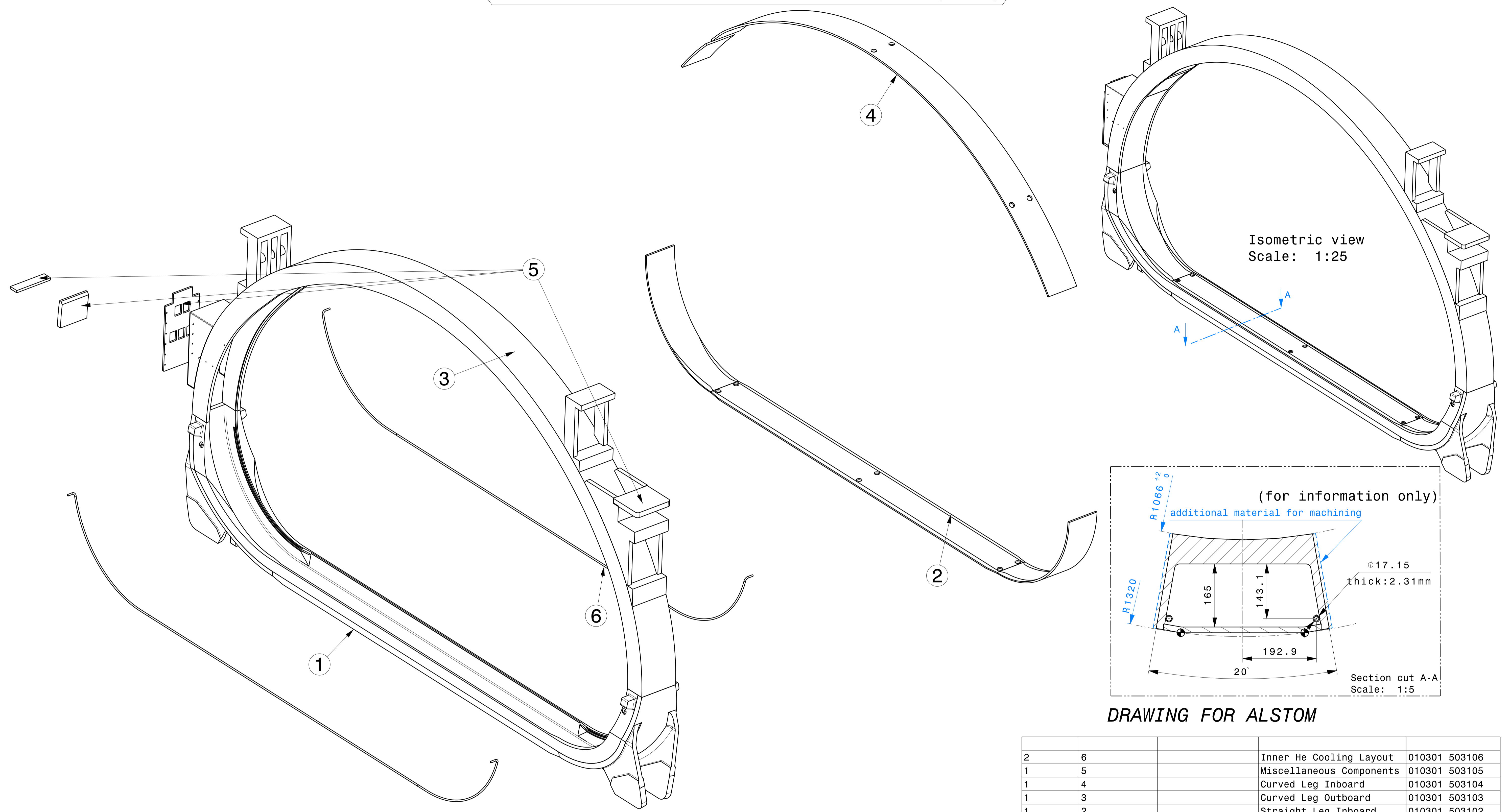

DRAWING FOR ALSTOM

Exploded Isometric view
Scale: 1:20

Note:
-Item 1,3 and 4 must be manufactured with reference to item 2
-the closures shown have only an indicative purpose, the final design of the bevel will be forwarded by ENEA on the base of the specification of the coil suppliers

Quantity	Balloon No.	Component Number	Component Description	Drawing Number
2	6		Inner He Cooling Layout	010301 503106
1	5		Miscellaneous Components	010301 503105
1	4		Curved Leg Inboard	010301 503104
1	3		Curved Leg Outboard	010301 503103
1	2		Straight Leg Inboard	010301 503102
1	1		Straight Leg Outboard	010301 503101

FOR CONTRACT		ref. to 3D CatProduct: 010301-203000	
CONFIDENTIAL UNLESS AUTHORISED <small>The information on this drawing is confidential under the terms of the BA agreement. This information shall not be transmitted to anyone who is not authorised to receive it.</small>	APPROVED BY A. CUCCHIARO	Fusion Italy-Frascati Research Centre	CUSTOMER: Fusion-for-Energy
	REVIEWED BY		DRAWING TITLE Casing Components Toroidal Field Coil
REV DATE 18-06-2012	CONTROLLED BY G.M.POLLI	CODE ENEA ID: DD-JT60TF-NCO	
FIRST ISSUE DATE 10-11-2011	SCALE NTS	DRAWN BY G.BROLATTI	
SHEET SIZE A1	FIRST ANGLE PROJECTION	WBS LEVELS 010301	Drawing Number 503100
			SHEET 01
			REVISION 03
			MATURITY

ITEM No	DRAWING No	DESCRIPTION	NO OFF	NO ORDERED	MATERIAL	SUPPLIER	DATE ORDERED	DATE DELIVERED	REMARKS
1	010301-503101	STRAIGHT LEG OUTBOARD							
2	010301-503102	STRAIGHT LEG INBOARD							
3	010301-503103	CURVED LEG OUTBOARD							
4	010301-503104	CURVED LEG INBOARD							
5	010301-503105	MISCELLANEUS COMPONENTS							
6	010301-503106	INNER He COOLING LAYOUT							
7	010301-503107	MOCK-UP STRAIGHT BEAM 1m LONG							
8	010301-503108	MOCK-UP STRAIGHT SAMPLE 50cm LONG							
9									
10									
11									
12									
13									
14									
15									
16									
17									
18									
19									
20									
21									
22									
23									
24									

ENEA **Fusion**
Italy-Frascati Research Centre

00	01	02	03	ISSUE
10-11-11	20-12-11	15-02-12	18-06-12	DATE
A				MATURITY

TITLE:-

DRN	GBROL
CHKD	
APPD	

CONFIDENTIAL UNLESS AUTHORISED
The information on this drawing is confidential under the terms of the BA agreement. This information shall not be transmitted to anyone who is not authorised to receive it.

CONTRACTOR: ALSTOM

ITEM LIST FOR CONTRACT

* 010301	503100
SHEET NO. 1	OF 1 SHEETS

PLANNING NOTES

Item list

**JT60-SA CASING COMPONENTS
TOROIDAL FIELD COIL**

C.A.D. DRAWN NOT TO BE MODIFIED BY HAND

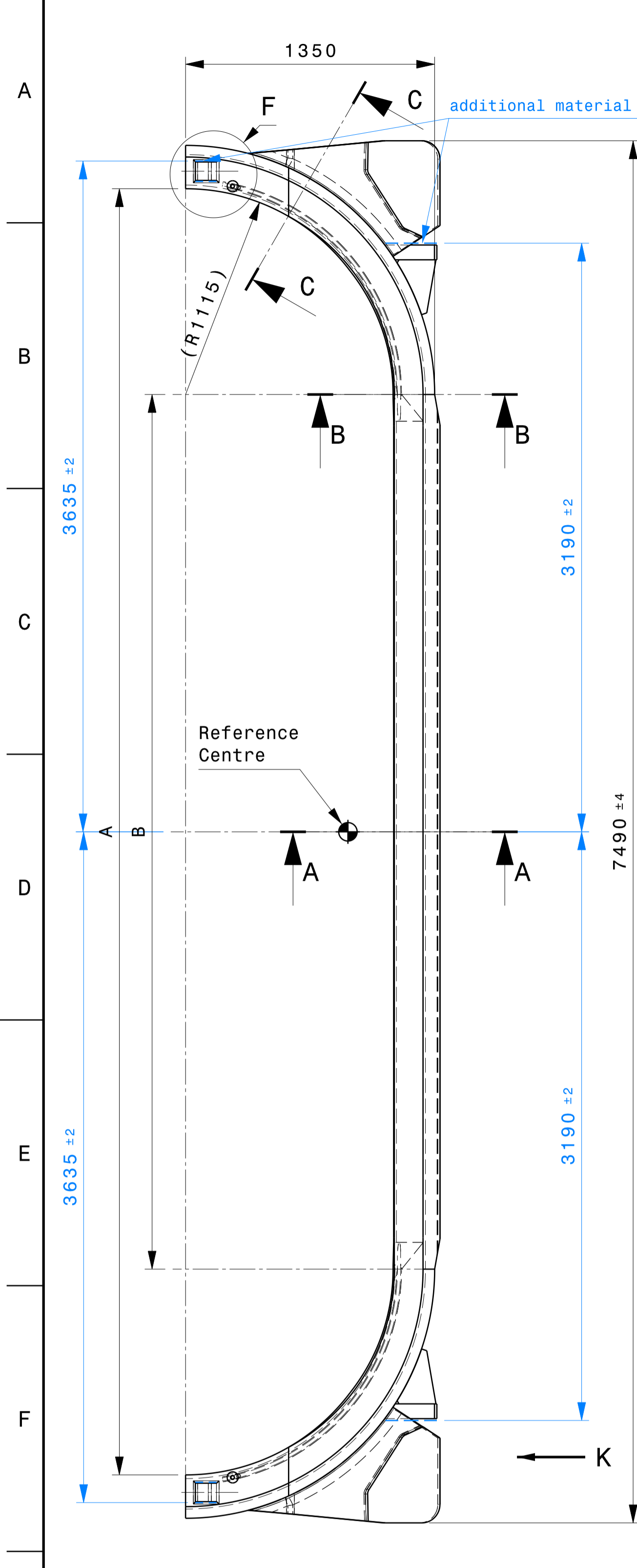

Front view
Scale: 1:20

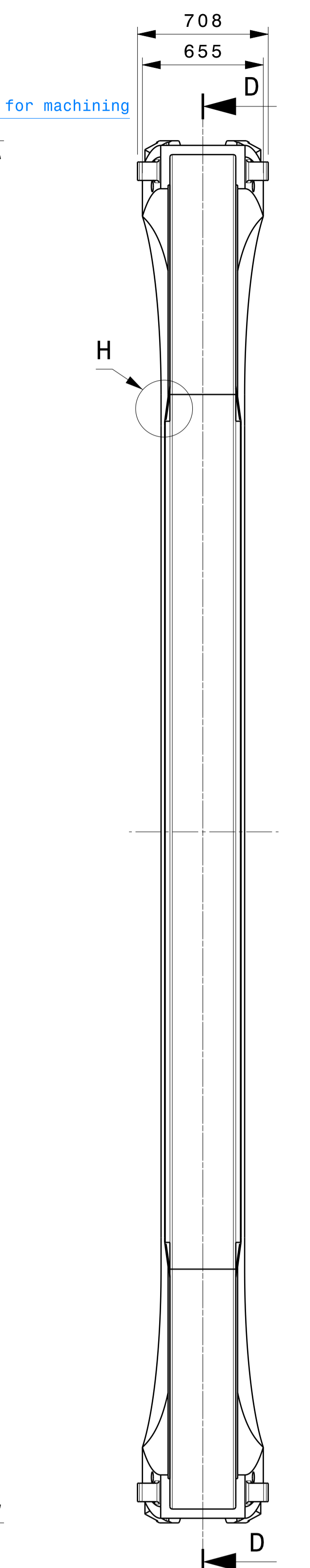

Left view
Scale: 1:20

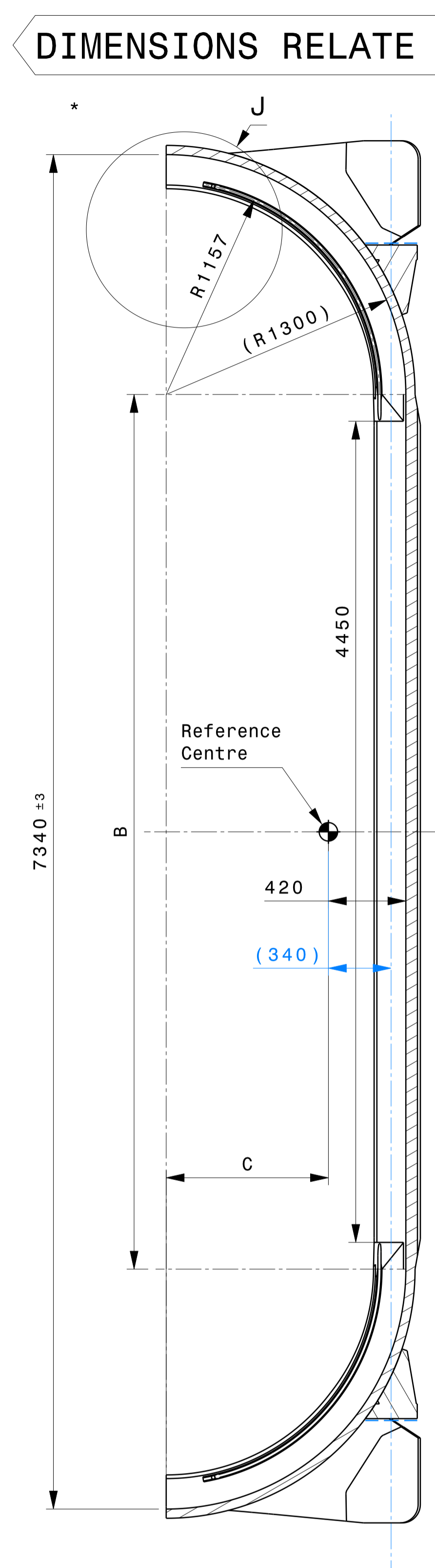

Section D-D
Scale: 1:20

DIMENSIONS RELATE TO ROOM TEMPERATURE (293K)

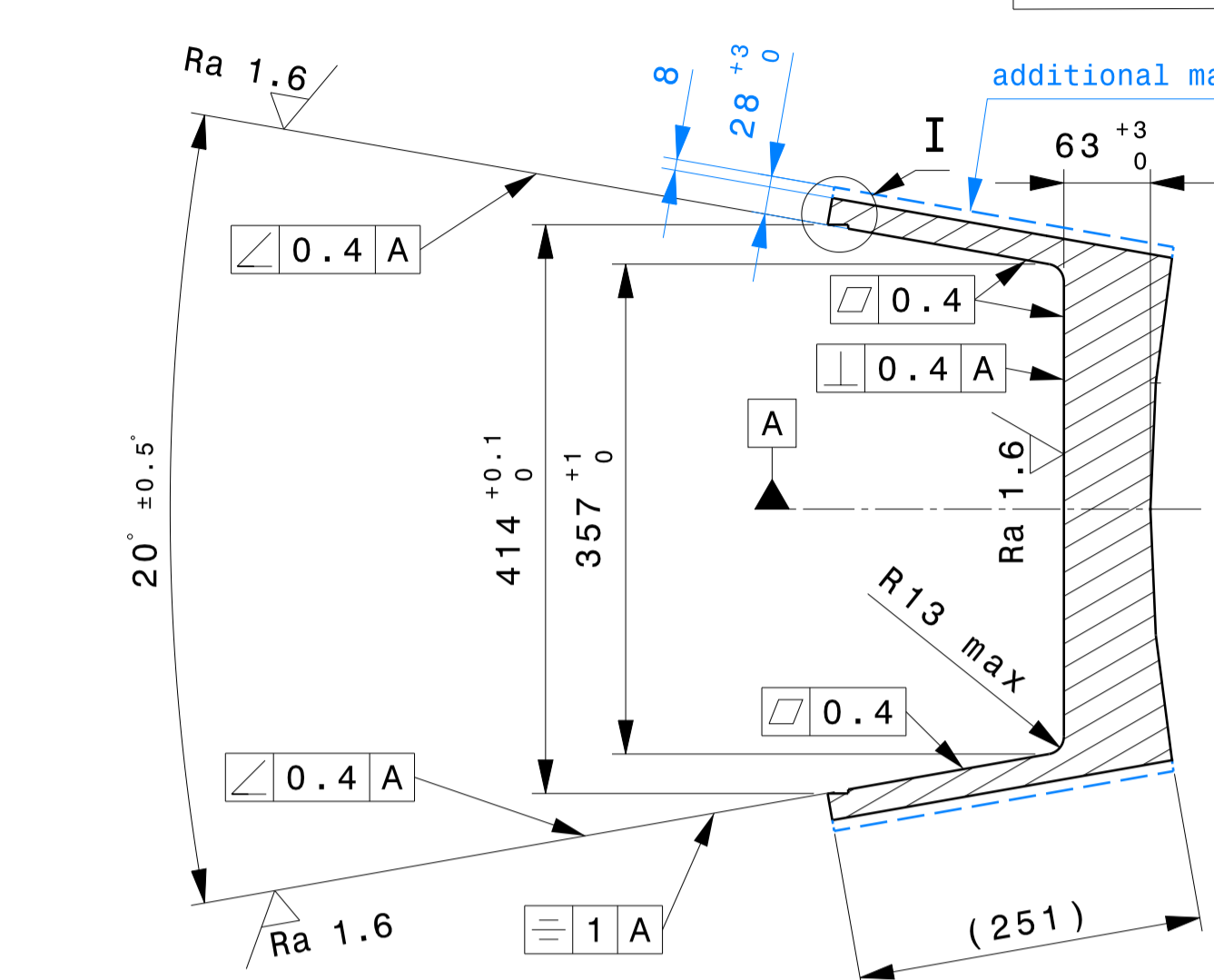

Section A-A
Scale: 1:5

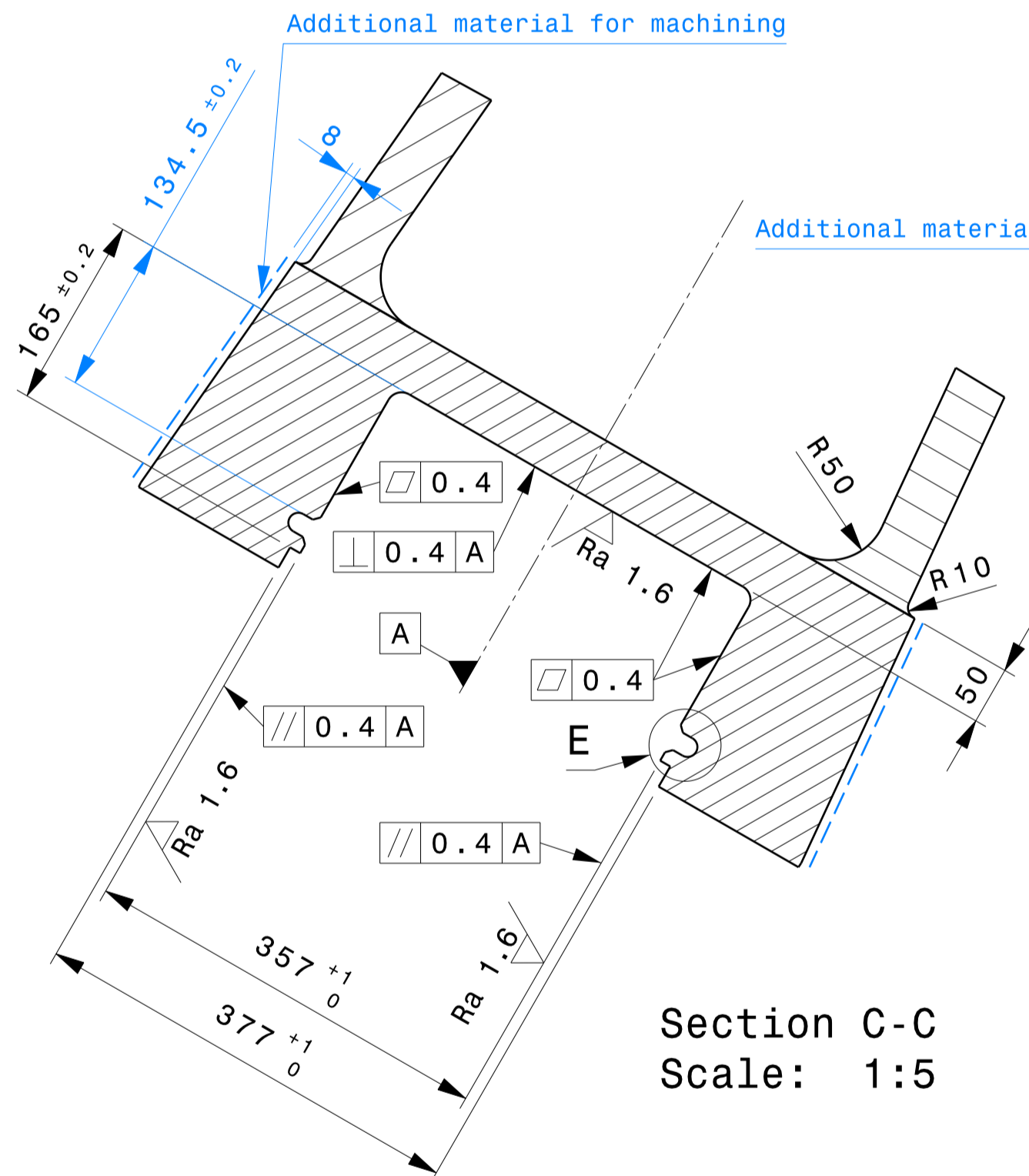

Section C-C
Scale: 1:5

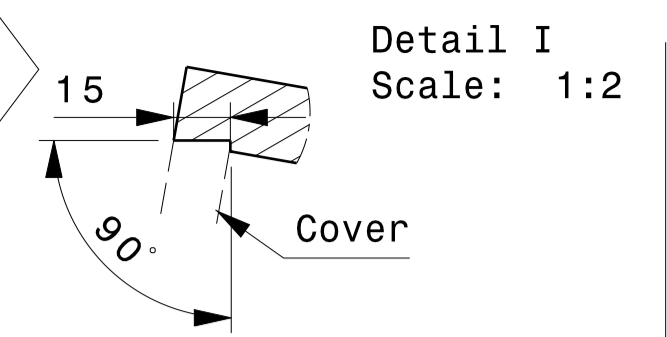

Detail I
Scale: 1:2

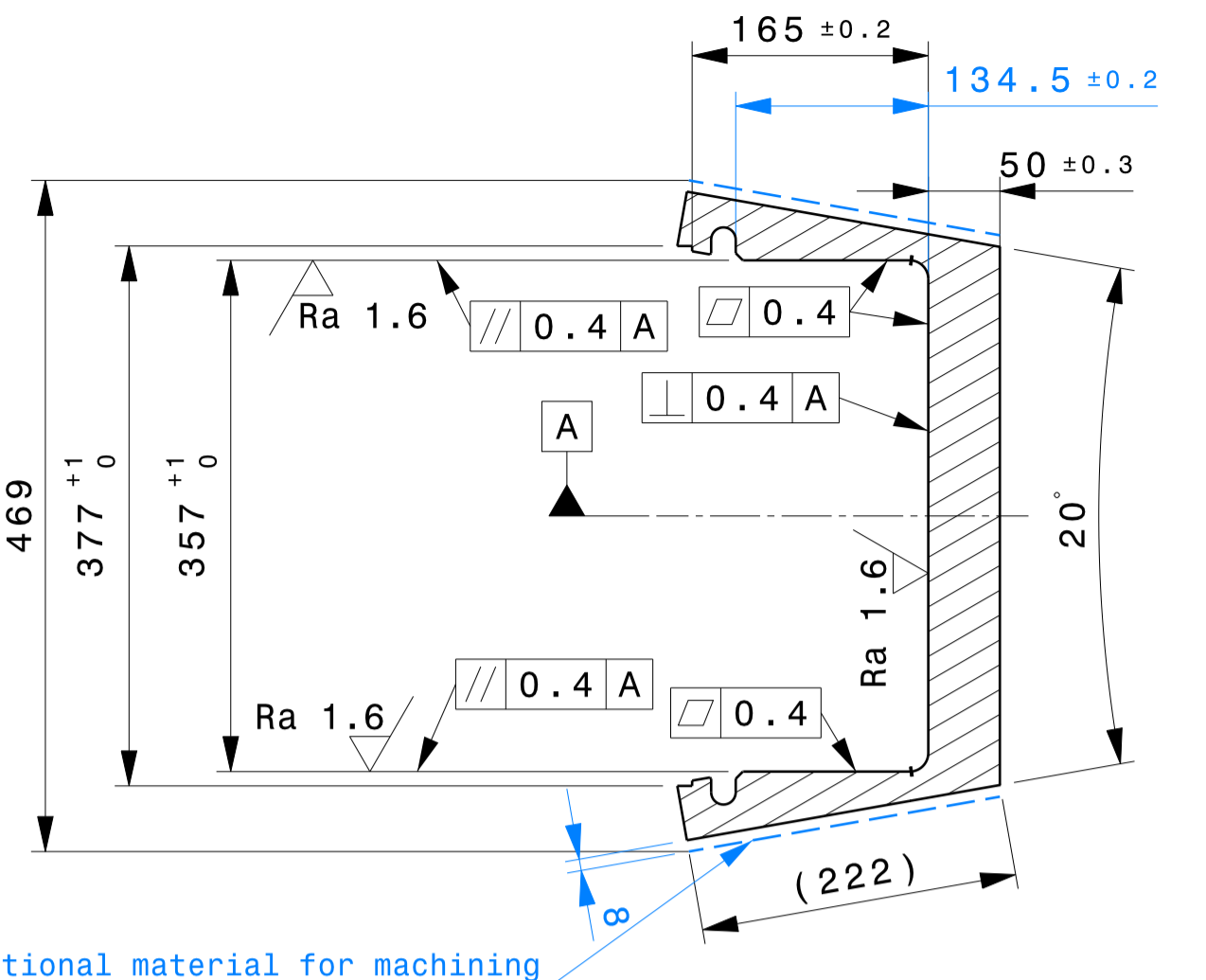

Section B-B
Scale: 1:5

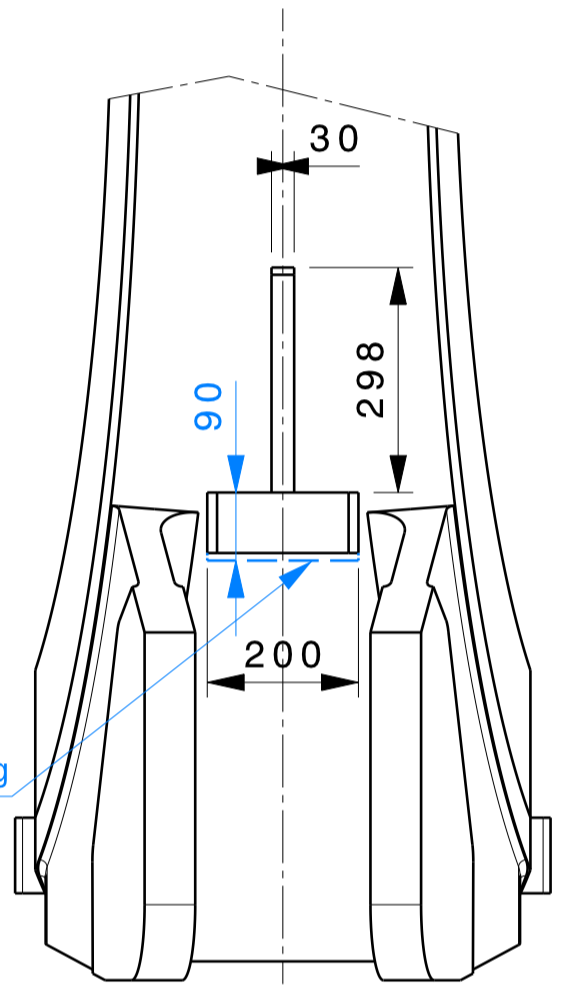

View K
Scale: 1:10

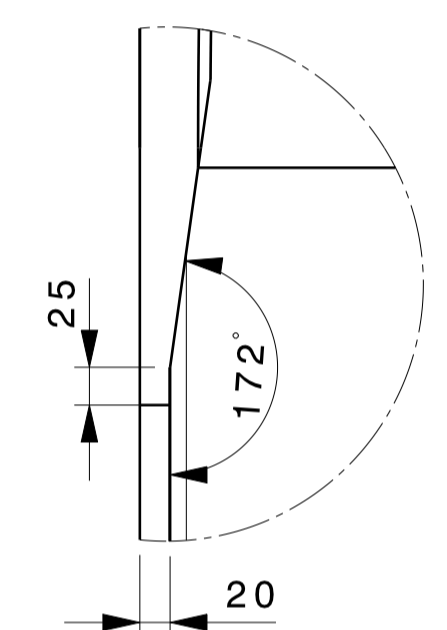

Detail H
Scale: 1:5

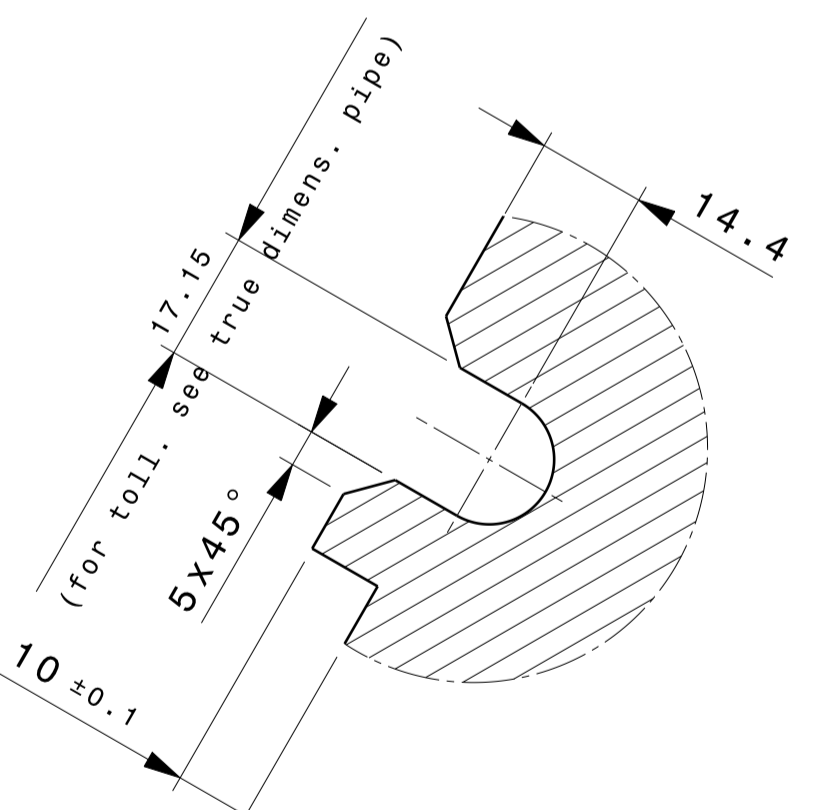

Detail E
Scale: 1:1

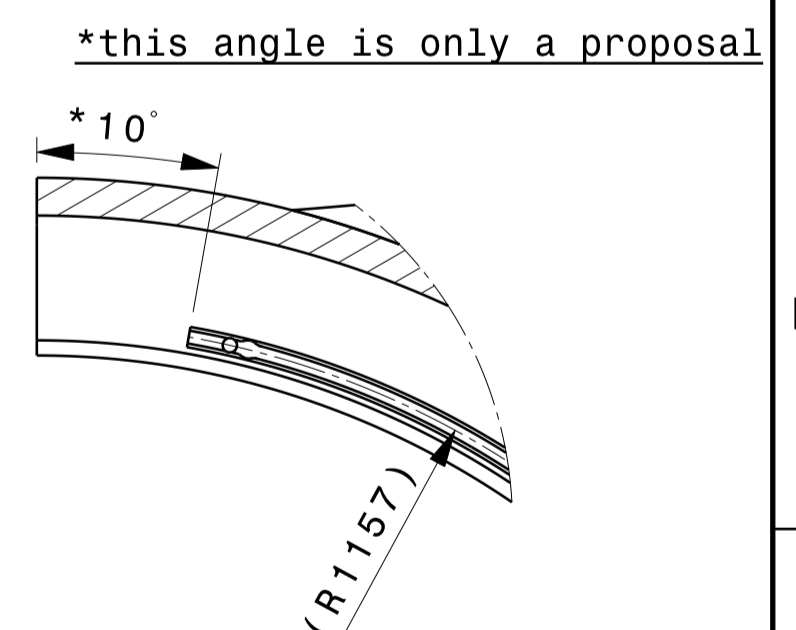

Detail J
Scale: 1:10

Note:
-DIN ISO 2768-1 & 2768-2 general medium tolerance class for all machining unless otherwise specified
-For dimensions A, B and C see drawing 010301 503002
-APPLY ROUGHNESS Ra 3.2 UNLESS OTHERWISE SPECIFIED

DRAWING FOR ALSTOM

FOR CONTRACT		ref. to 3D CatProduct: 010301-203001	
CONFIDENTIAL UNLESS AUTHORISED <small>The information on this drawing is confidential under the terms of the BA agreement. This information shall not be transmitted to anyone who is not authorised to receive it.</small>		APPROVED BY A. CUCCHIARO	CUSTOMER: Fusion-for-Energy
REV DATE 18-06-2012		REVIEWED BY	DRAWING TITLE Straight Leg Outboard Toroidal Field Coil
FIRST ISSUE DATE 10-11-2011	SCALE NTS	CHECKED BY	CODE ENEA ID: DD-JT60TF-NCO
SHEET SIZE A1	FIRST ANGLE PROJECTION	CONTROLLED BY G.M.POLLI	DRAWING NUMBER 503101
		DRAWN BY G. BROLATTI	SHEET REVISION MATURITY 01 02
		WBS LEVELS 010301	

DIMENSIONS RELATE TO ROOM TEMPERATURE (293K)

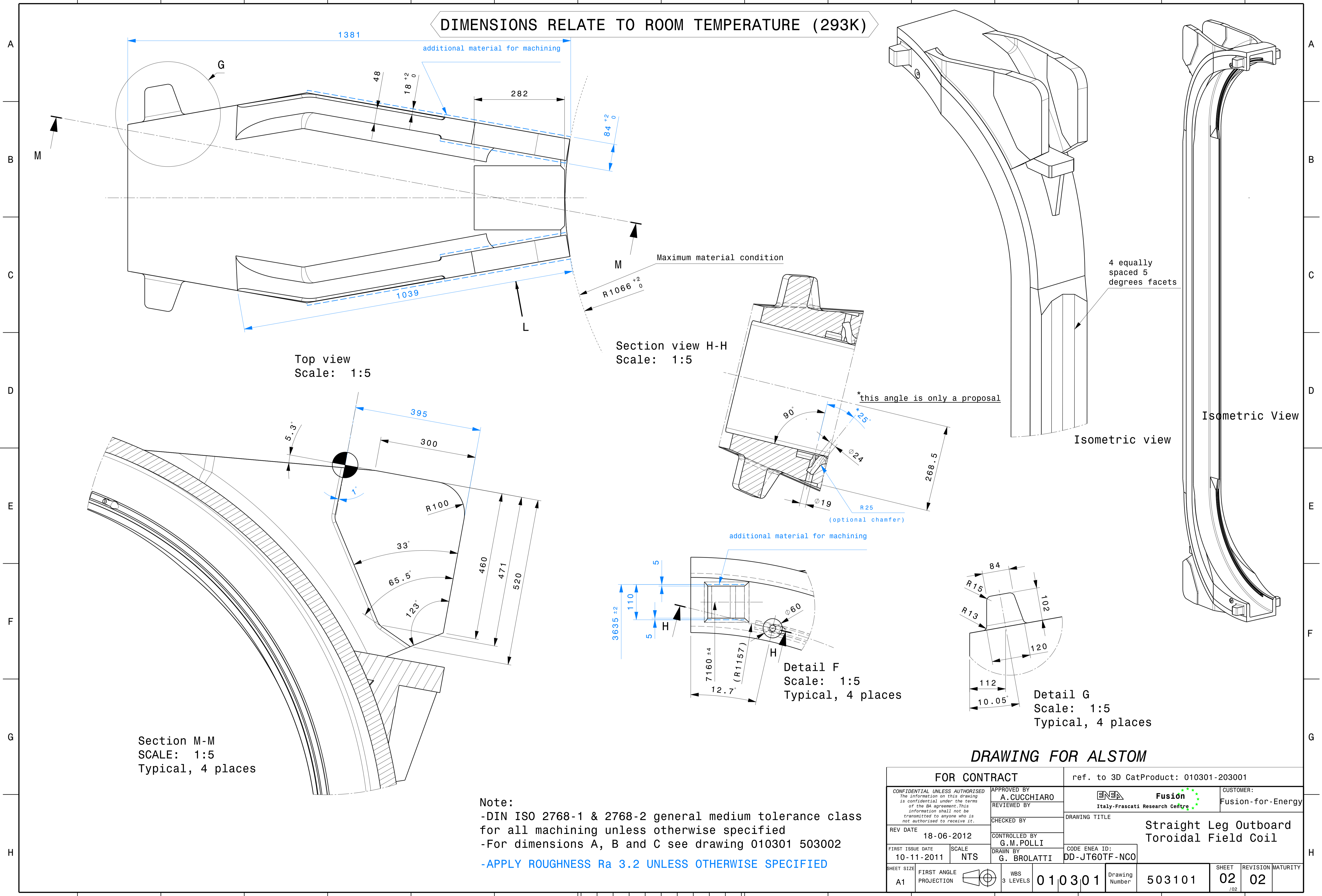

Note:
 -DIN ISO 2768-1 & 2768-2 general medium tolerance class for all machining unless otherwise specified
 -For dimensions A, B and C see drawing 010301 503002
 -APPLY ROUGHNESS Ra 3.2 UNLESS OTHERWISE SPECIFIED

DRAWING FOR ALSTOM

FOR CONTRACT		ref. to 3D CatProduct: 010301-203001	
<small>CONFIDENTIAL UNLESS AUTHORISED</small>		APPROVED BY A. CUCCHIARO	CUSTOMER: Fusion-for-Energy
<small>The information on this drawing is confidential under the terms of the BA agreement. This information shall not be transmitted to anyone who is not authorised to receive it.</small>		REVIEWED BY	DRAWING TITLE Straight Leg Outboard Toroidal Field Coil
		CHECKED BY	
REV DATE 18-06-2012	SCALE NTS	CONTROLLED BY G.M.POLLI	CODE ENEA ID: DD-JT60TF-NCO
FIRST ISSUE DATE 10-11-2011		DRAWN BY G. BROLATTI	
SHEET SIZE A1	FIRST ANGLE PROJECTION	WBS LEVELS 3	Drawing Number 010301
			503101
			SHEET 02
			REVISION 02
			MATURITY

DIMENSIONS RELATE TO ROOM TEMPERATURE (293K)

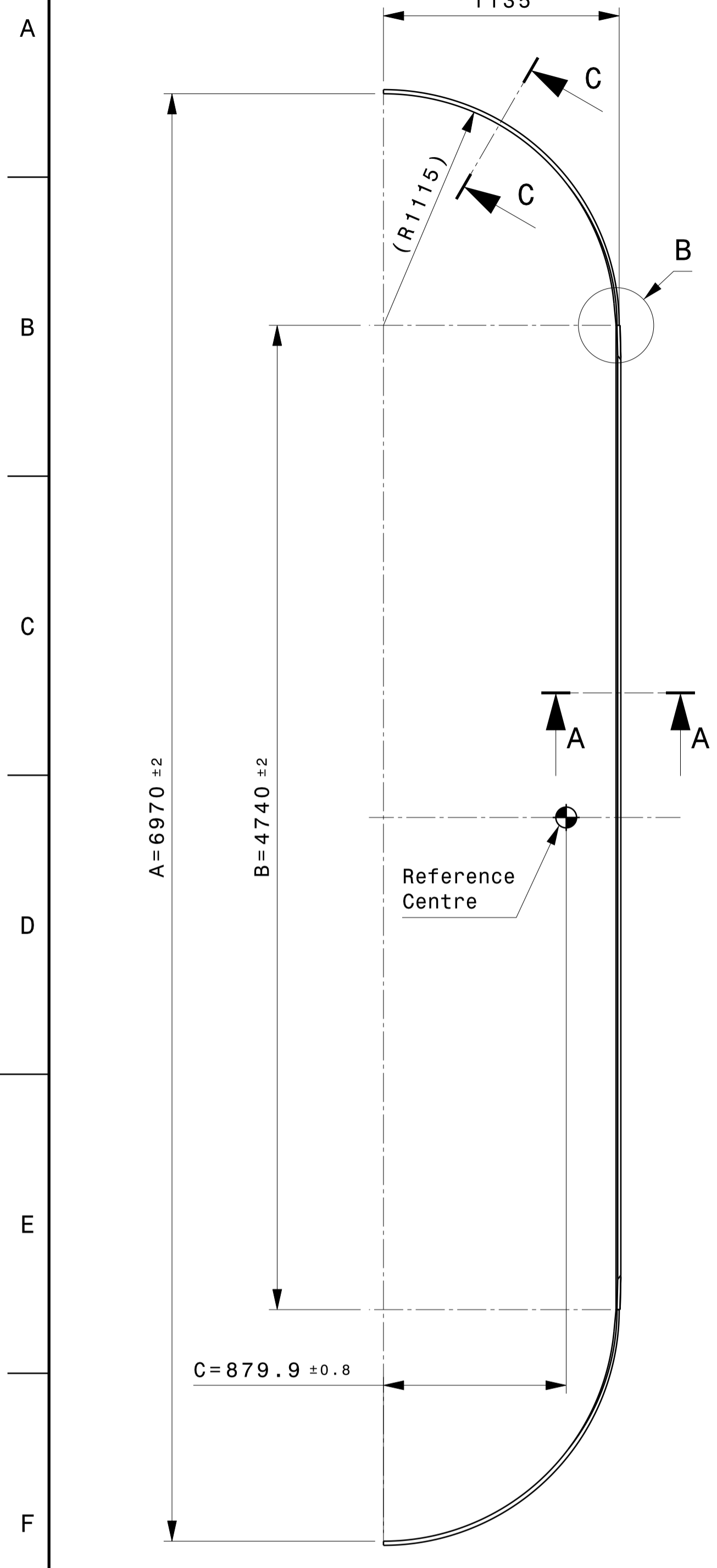

Front view
Scale: 1:20

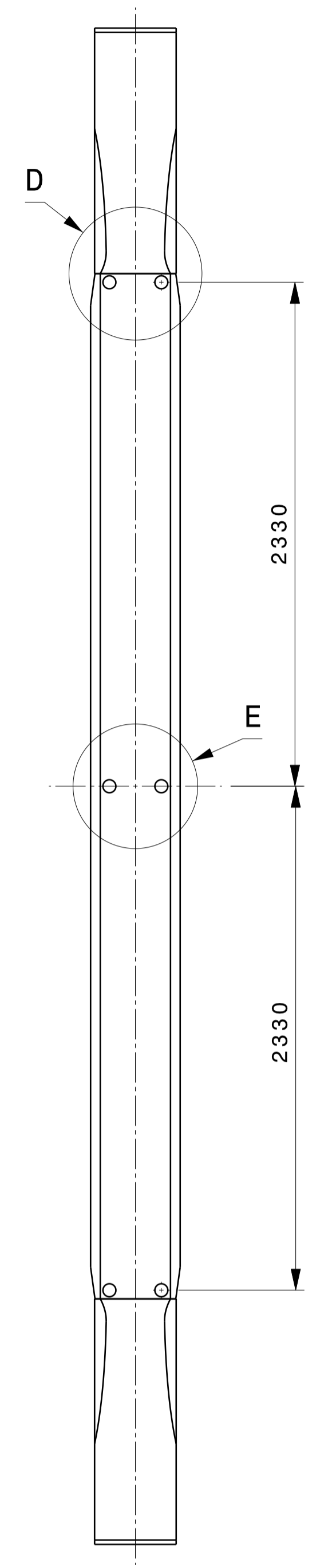

Left view
Scale: 1:20

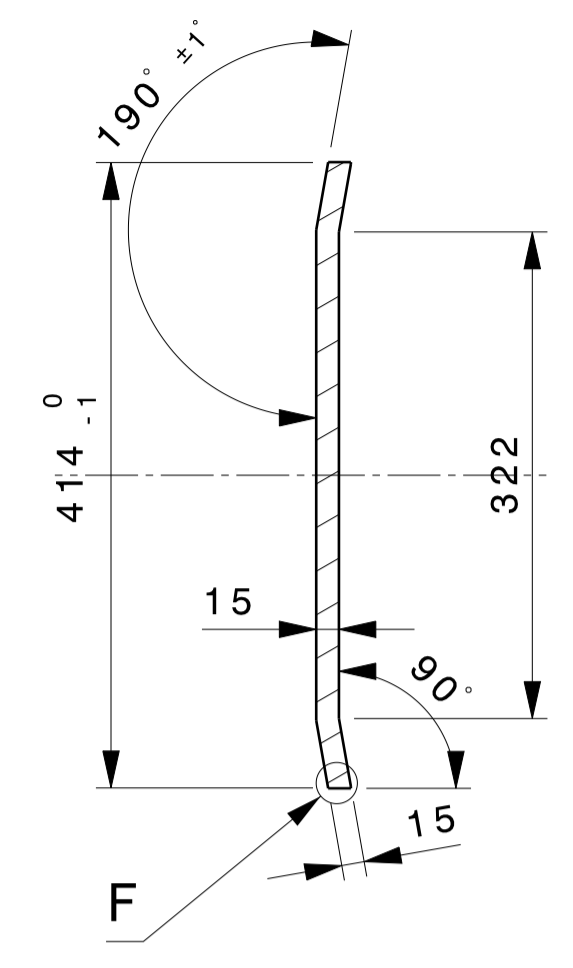

Section A-A
Scale: 1:5

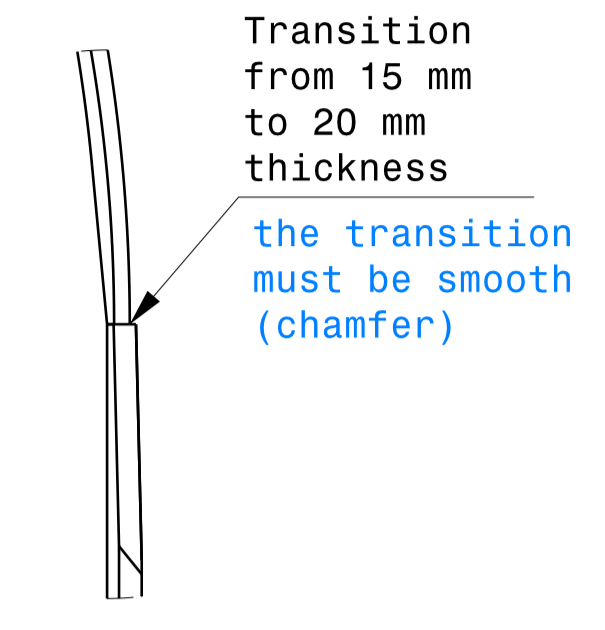

Detail B
Scale: 1:5

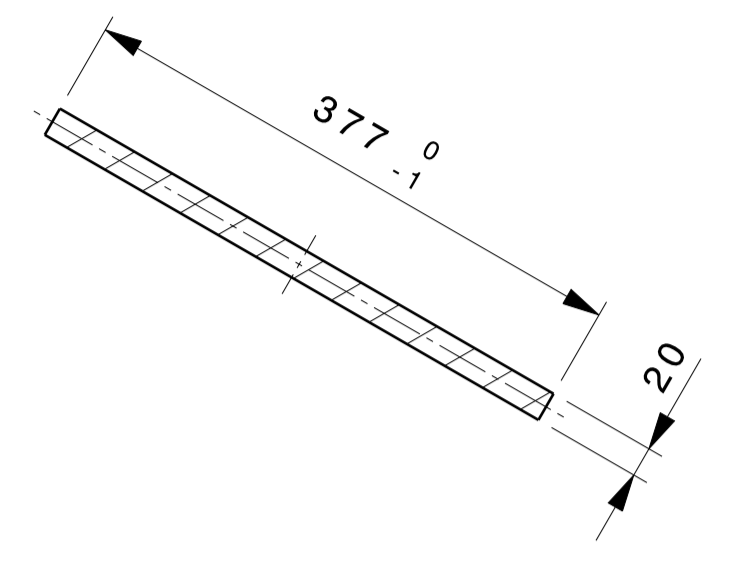

Section C-C
Scale: 1:5

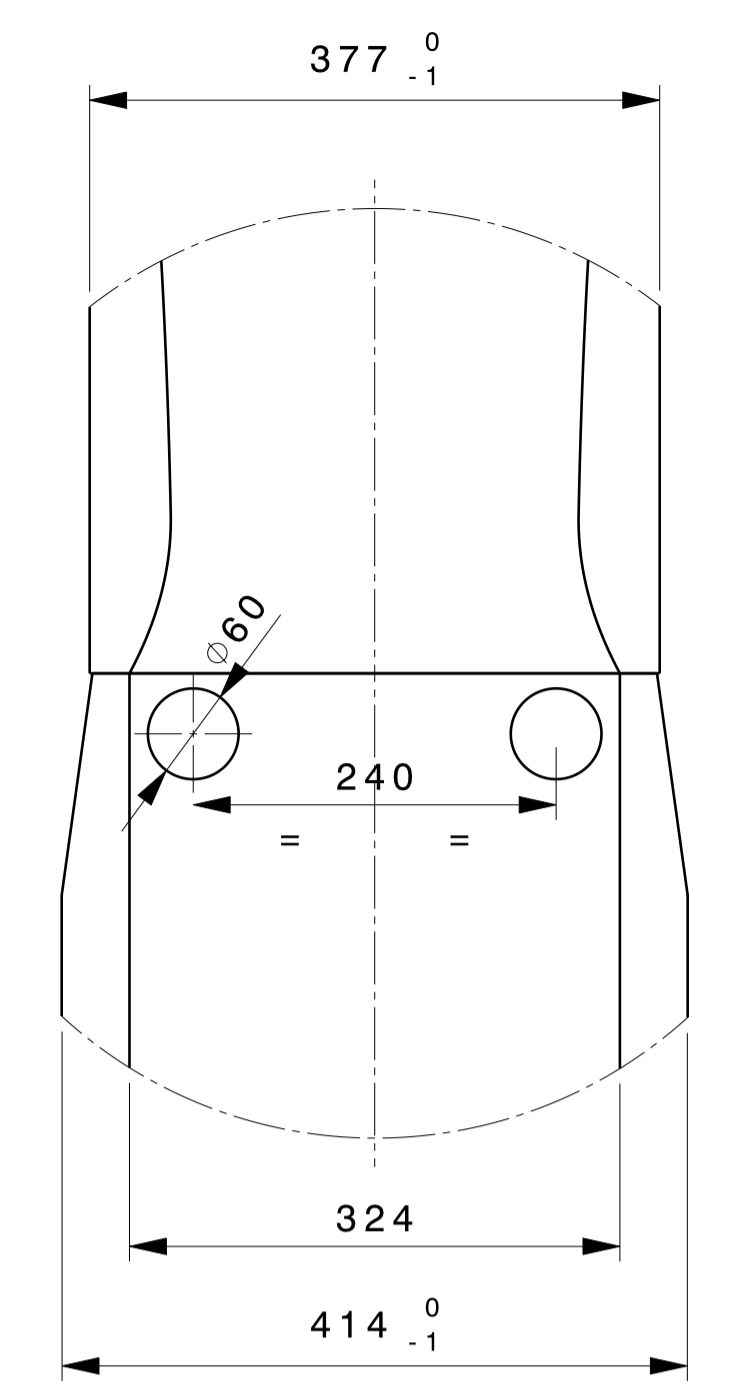

Detail D
Scale: 1:5

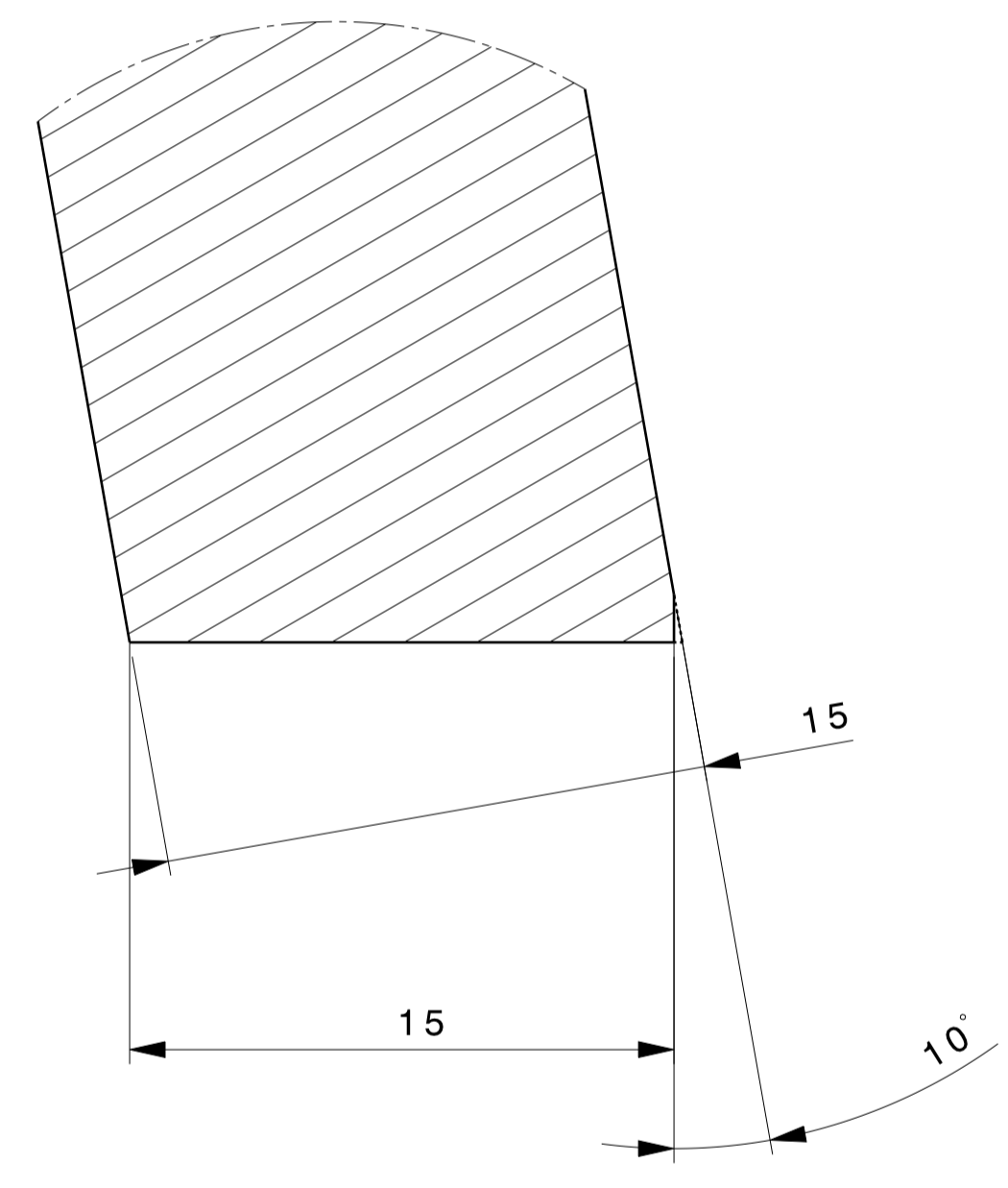

Detail F
Scale: 5:1

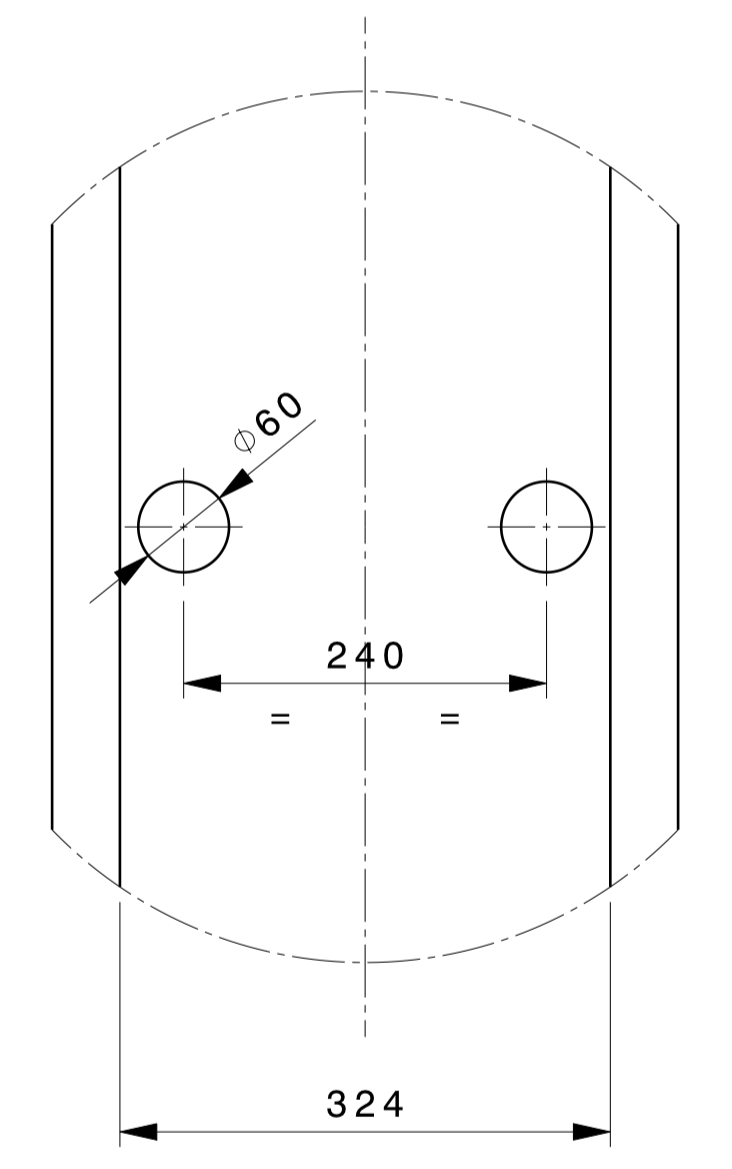

Detail E
Scale: 1:5

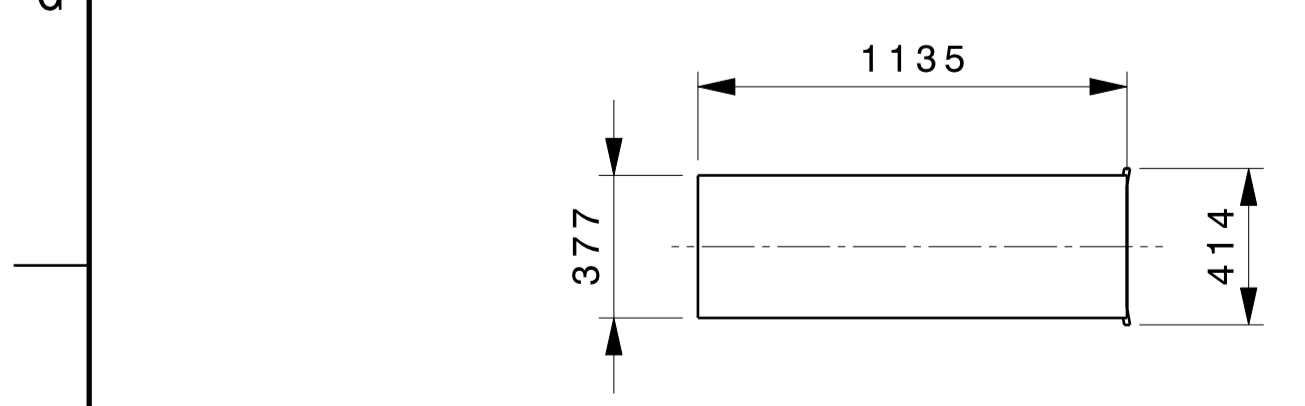

Top view
Scale: 1:20

Note:
 -DIN ISO 2768-1 & 2768-2 general medium tolerance class for all machining unless otherwise specified
 -A is required for machining of mating parts see drawing 010301 503001, 010301 503003, 010301 503004
 -B is required for machining of mating part see drawing 010301 503001
 -C is required for machining of mating parts see drawing 010301 503001, 010301 503003, 010301 503004
 -APPLY ROUGHNESS Ra 3.2 UNLESS OTHERWISE SPECIFIED

DRAWING FOR ALSTOM

FOR CONTRACT		ref. to 3D CatProduct: 010301-203002	
CONFIDENTIAL UNLESS AUTHORISED <small>The information on this drawing is confidential under the terms of the BA agreement. This information shall not be transmitted to anyone who is not authorised to receive it.</small>	APPROVED BY A. CUCCHIARO	Fusion Italy-Frascati Research Centre	CUSTOMER: Fusion-for-Energy
	REVIEWED BY		DRAWING TITLE Straight leg inboard Toroidal Field Coil
REV DATE 18-06-2012	CONTROLLED BY G.M.POLLI	CODE ENEA ID: DD-JT60TF-NCO	
FIRST ISSUE DATE 10-11-2011	SCALE NTS	DRAWN BY G. BROLATTI	
SHEET SIZE A1	FIRST ANGLE PROJECTION	WBS LEVELS 010301	Drawing Number 503102
			SHEET REVISION MATURITY 01 03

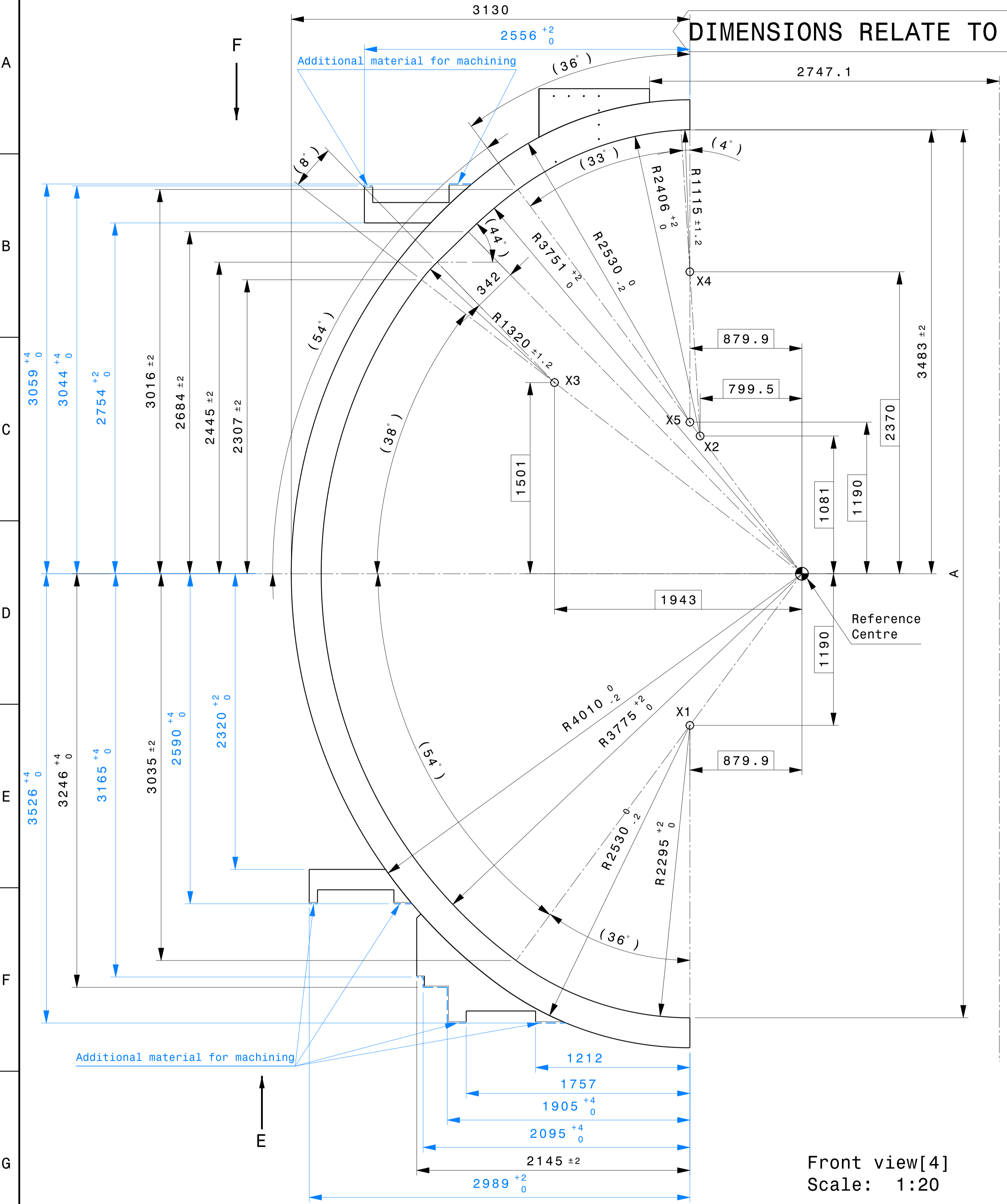

Front view[4]
Scale: 1:20

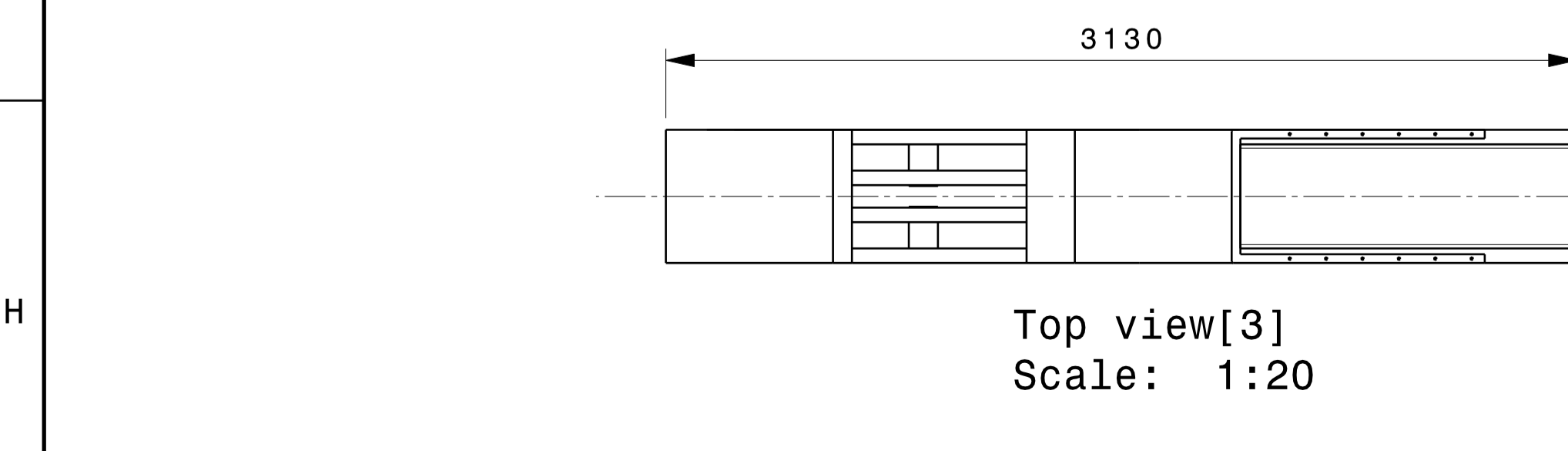

Top view[3]
Scale: 1:20

Note:
 -DIN ISO 2768-1 & 2768-2 general medium tolerance class for all machining unless otherwise specified
 -For dimension A see drawing 010301 503002
 -For dimension C see drawing 010301 503002
 -X1, X2, X3, X4, X5 are the centre points of the radii
 -For machining of all inner surfaces radii must blend
 -APPLY ROUGHNESS Ra 3.2 UNLESS OTHERWISE SPECIFIED

DIMENSIONS RELATE TO ROOM TEMPERATURE (293K)

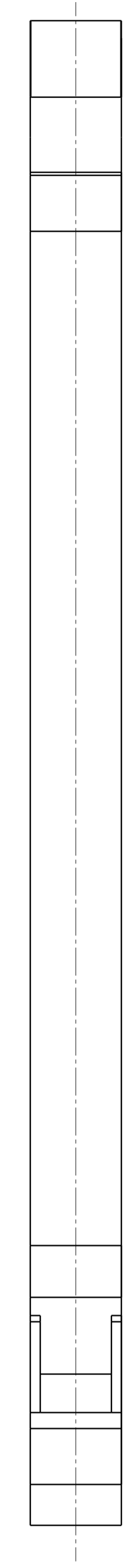

Left view[2]
Scale: 1:20

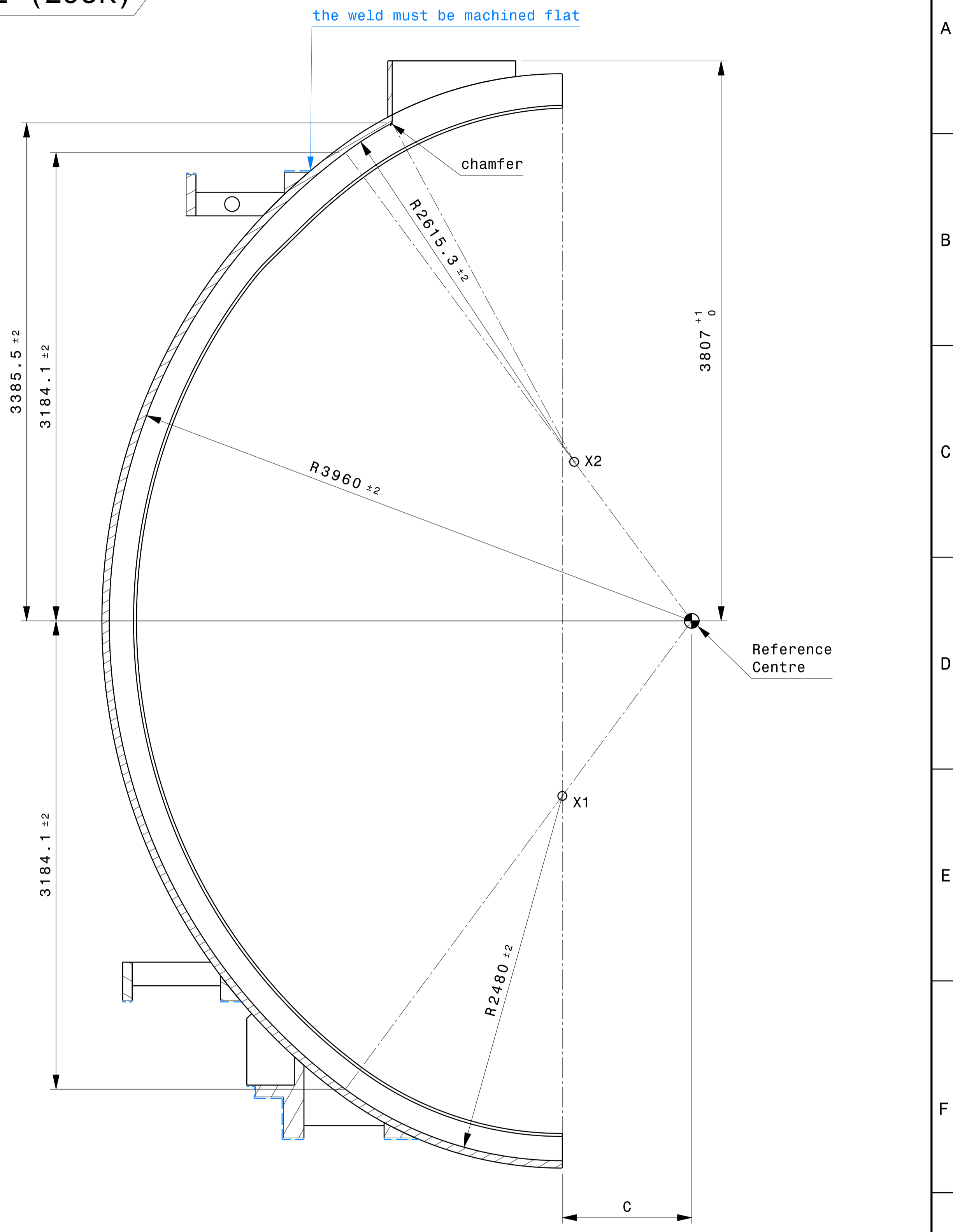

Section C-C
Scale: 1:20

DRAWING FOR ALSTOM

FOR CONTRACT		ref. to 3D CatProduct: 010301-203003	
CONFIDENTIAL UNLESS AUTHORISED The information on this drawing is confidential under the terms of the BA agreement. This information shall not be transmitted to anyone who is not authorised to receive it.	APPROVED BY A. CUCCHIARO	 Italy-Frascati Research Centre	CUSTOMER: Fusion-for-Energy
	REVIEWED BY		DRAWING TITLE Curved Leg Outboard Toroidal Field Coil
REV DATE 18-06-2012	CONTROLLED BY G.M. POLLI	CODE ENEA ID: DD-JT60TF-NCO	
FIRST ISSUE DATE 10-11-2011	SCALE NTS	DRAWN BY G. BROLATTI	
SHEET SIZE A1	FIRST ANGLE PROJECTION	WBS LEVELS 3 LEVELS	010301
		Drawing Number 503103	SHEET 01
			REVISION 03
			MATURITY

DIMENSIONS RELATE TO ROOM TEMPERATURE (293K)

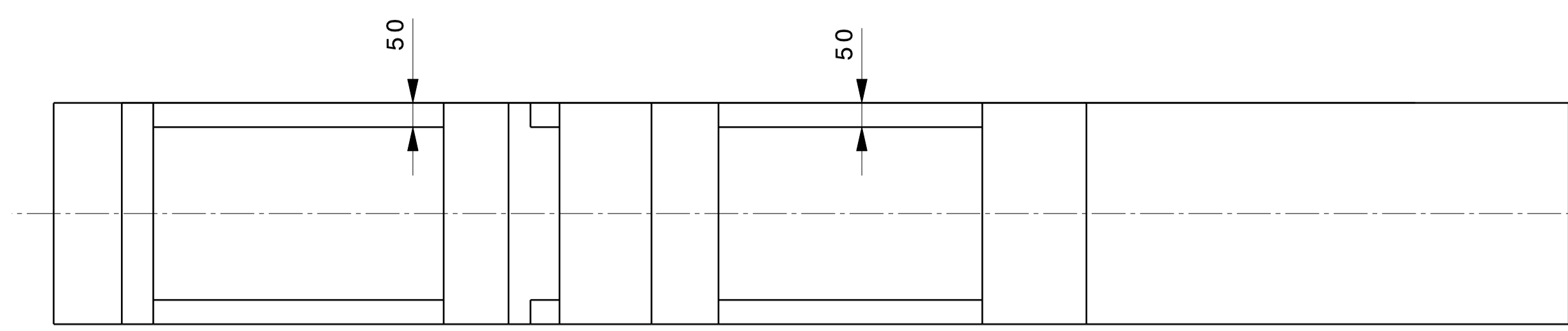

View E
Scale: 1:10

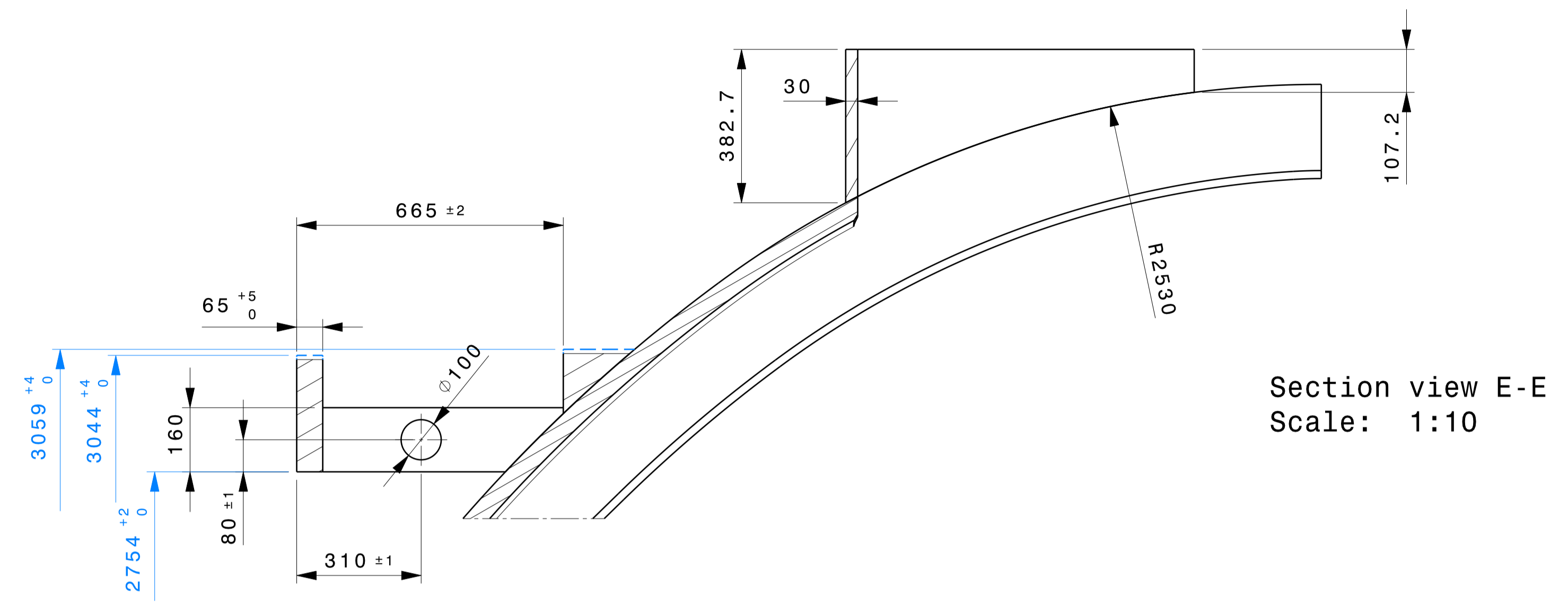

Section view E-E
Scale: 1:10

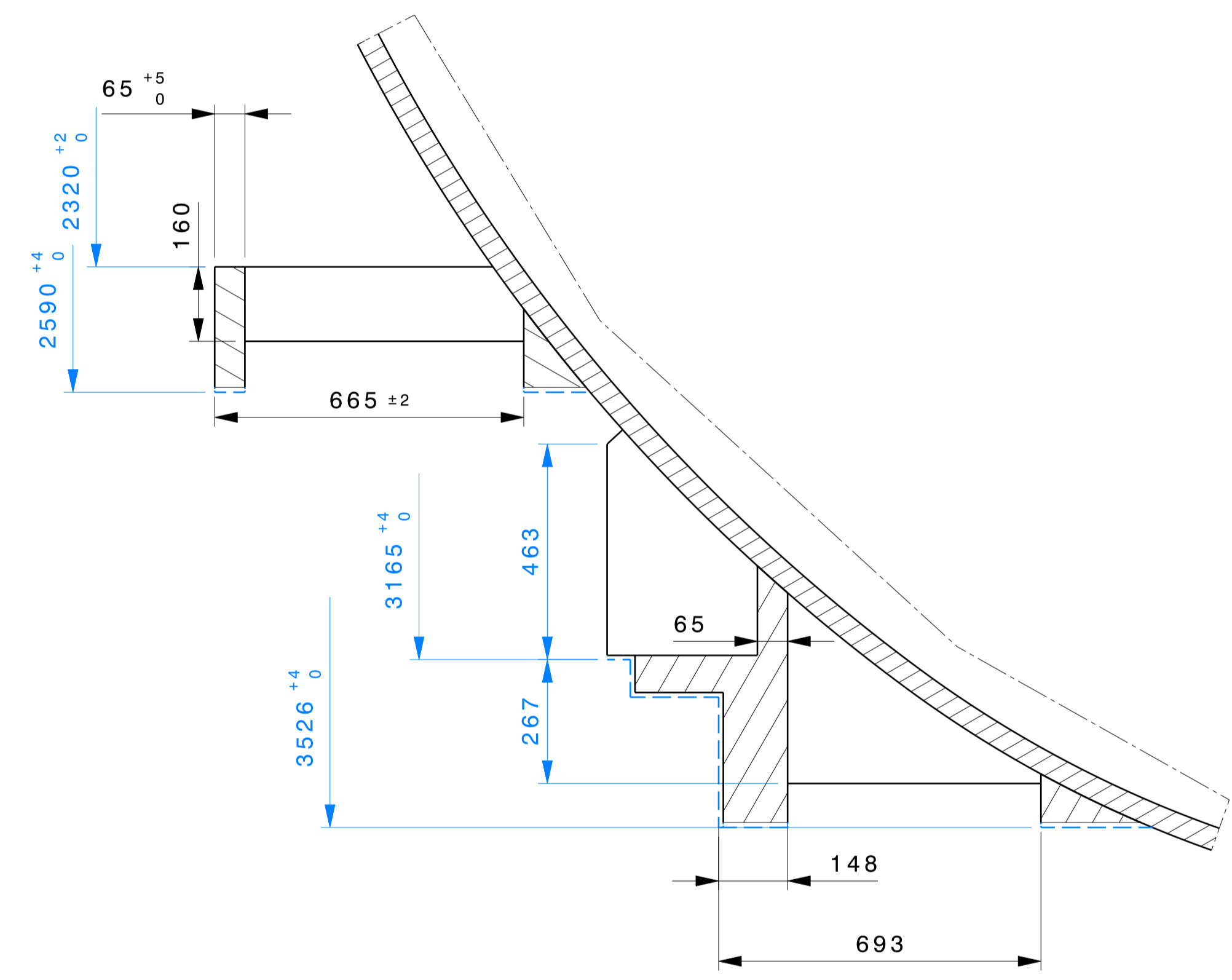

Detail D
Scale: 1:10

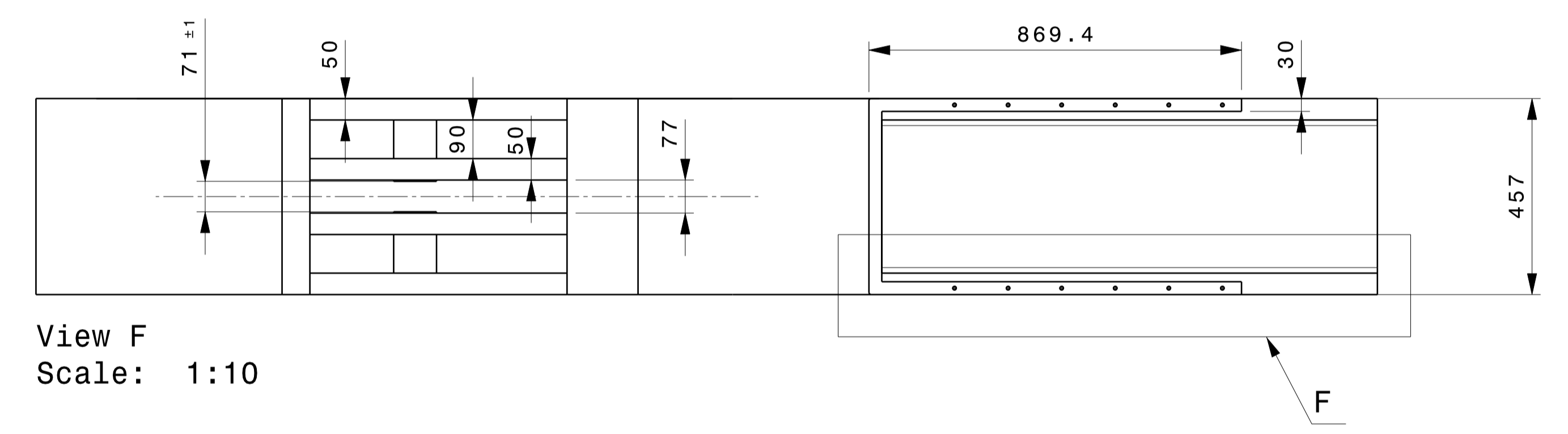

View F
Scale: 1:10

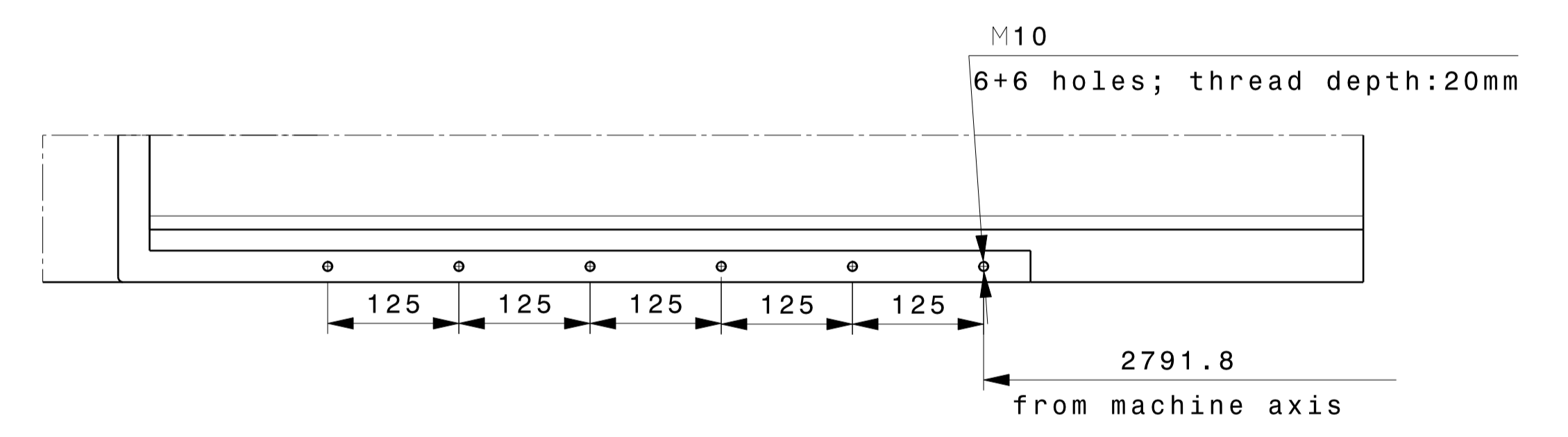

Detail F

Note:
 -DIN ISO 2768-1 & 2768-2 general medium tolerance class for all machining unless otherwise specified
 -For dimension A see drawing 010301 503002
 -For dimension C see drawing 010301 503002
 -X1, X2, X3, X4, X5 are the centre points of the radii
 -For machining of all inner surfaces radii must blend
 -APPLY ROUGHNESS Ra 3.2 UNLESS OTHERWISE SPECIFIED

DRAWING FOR ALSTOM

FOR CONTRACT		ref. to 3D CatProduct: 010301-203003	
CONFIDENTIAL UNLESS AUTHORISED The information on this drawing is confidential under the terms of the BA agreement. This information shall not be transmitted to anyone who is not authorised to receive it.	APPROVED BY A.CUCCHIARO	Fusion Italy-Frascati Research Centre	CUSTOMER: Fusion-for-Energy
	REVIEWED BY		DRAWING TITLE Curved Leg Outboard Toroidal Field Coil
REV DATE 18-06-2012	CONTROLLED BY G.M.POLLI	CODE ENEA ID: DD-JT60TF-NCO	
FIRST ISSUE DATE 10-11-2011	SCALE		
SHEET SIZE A1	FIRST ANGLE PROJECTION	WBS LEVELS 010301	Drawing Number 503103
			SHEET REVISION MATURITY 02 03

DIMENSIONS RELATE TO ROOM TEMPERATURE (293K)

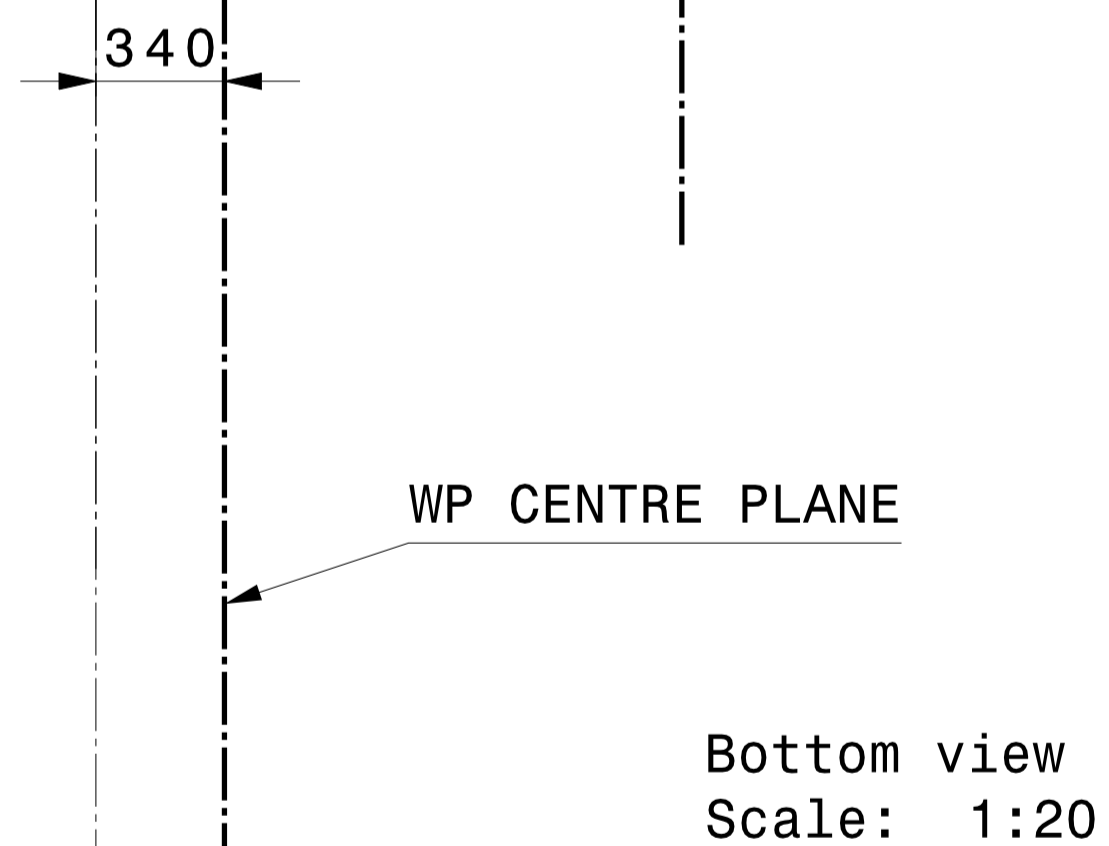
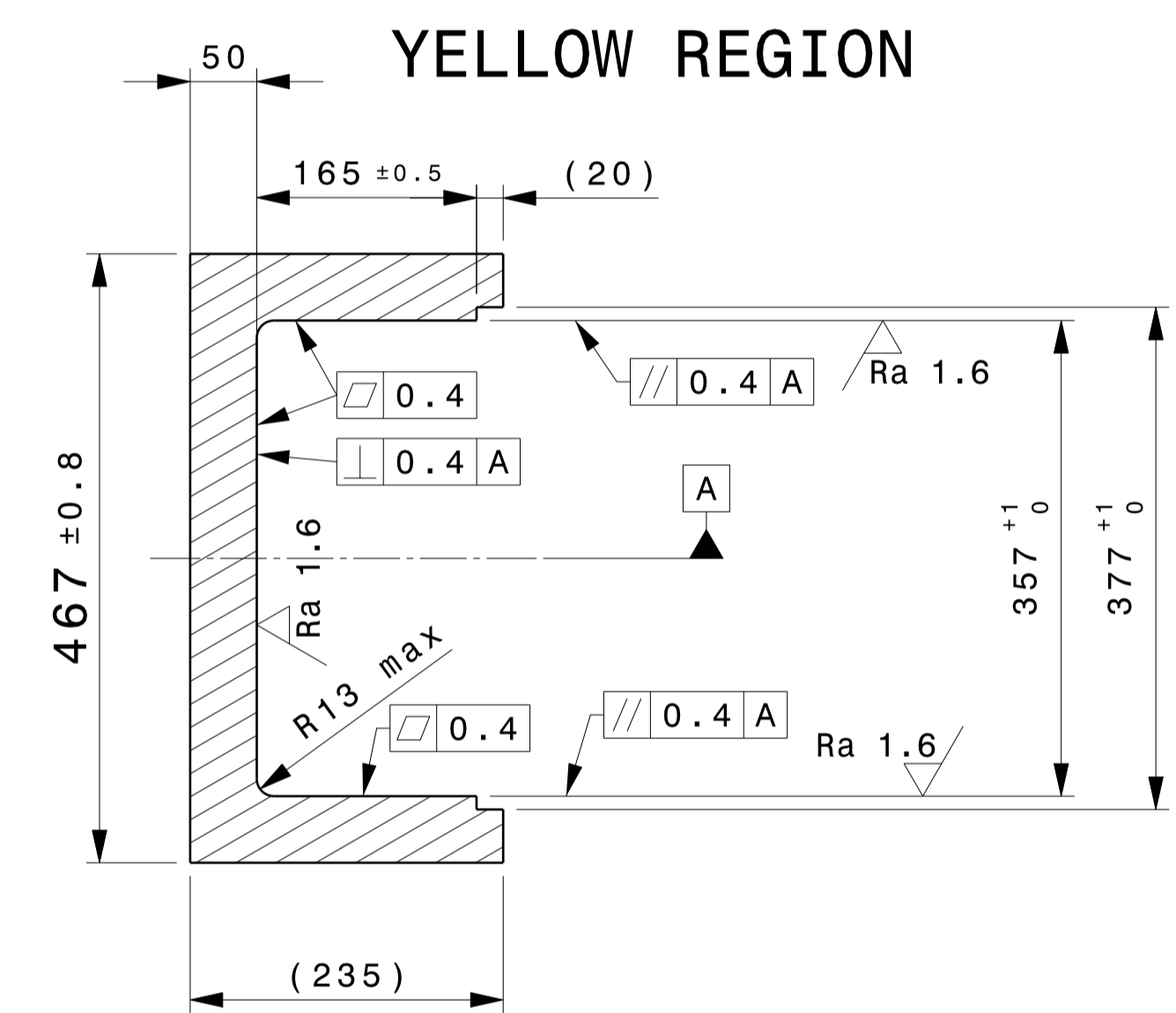
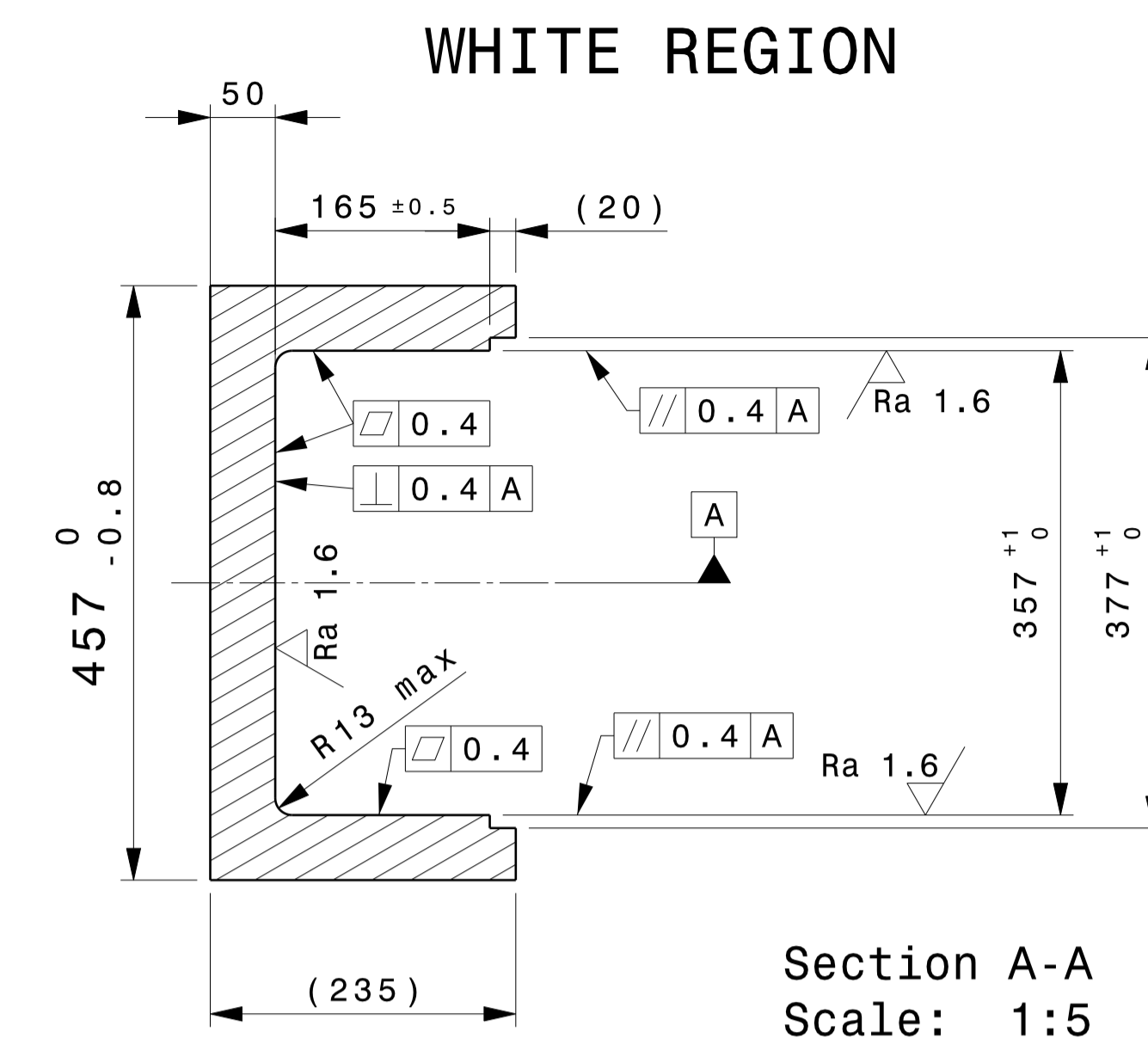
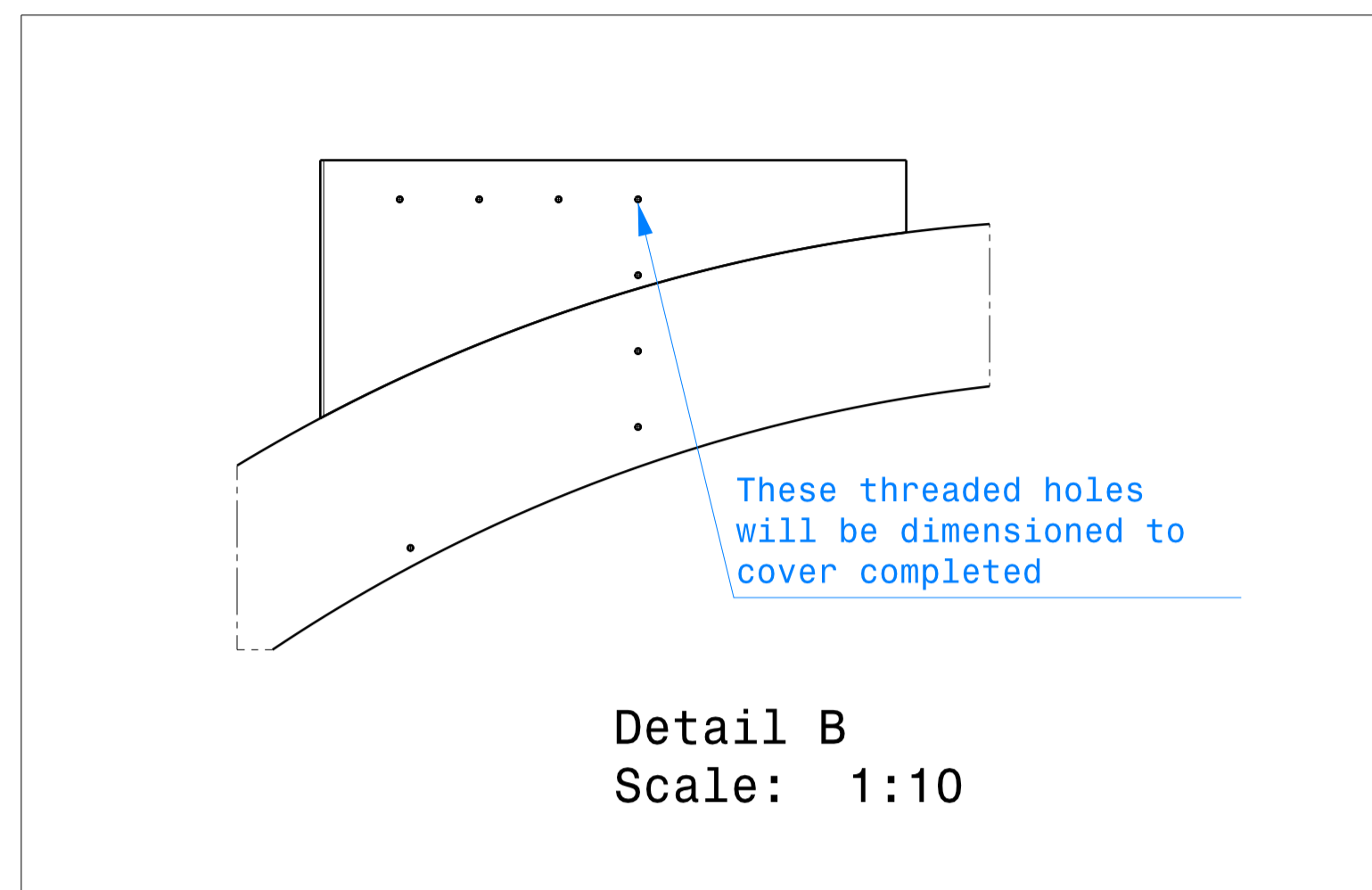
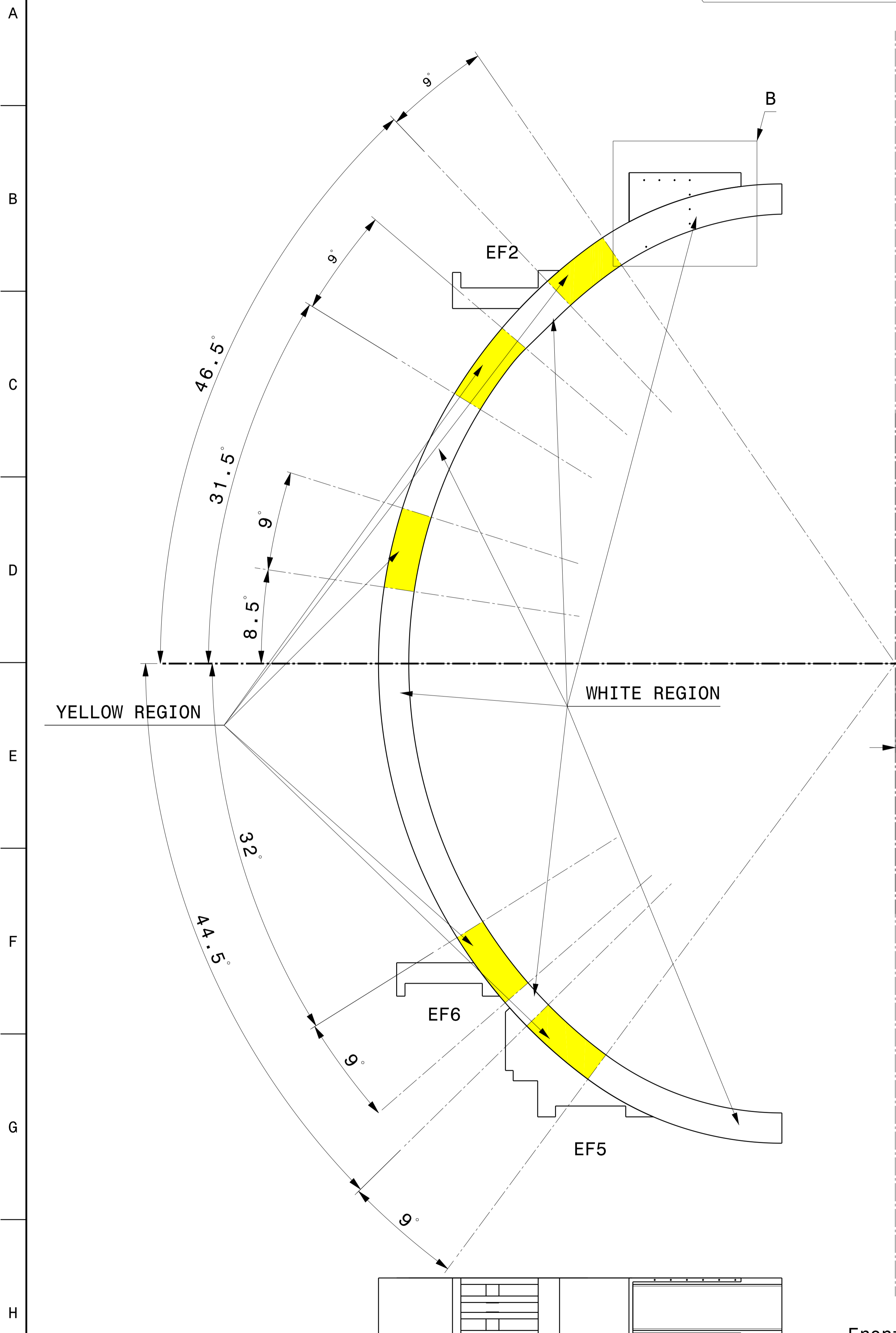

NOTE:
 -DIN ISO 2768-1 & 2768-2 general medium tolerance class for all machining unless otherwise specified
 -APPLY ROUGHNESS Ra 3.2 UNLESS OTHERWISE SPECIFIED

DRAWING FOR ALSTOM

FOR CONTRACT		ref. to 3D CatProduct: 010301-203003	
CONFIDENTIAL UNLESS AUTHORISED The information on this drawing is confidential under the terms of the BA agreement. This information shall not be transmitted to anyone who is not authorised to receive it.	APPROVED BY A. CUCCHIARO		CUSTOMER: Fusion-for-Energy
	REVIEWED BY		DRAWING TITLE Curved Leg Outboard Toroidal Field Coil
REV DATE 18-06-2012	CHECKED BY	CONTROLLED BY G.M. POLLI	CODE ENEA ID: DD-JT60TF-NCO
FIRST ISSUE DATE 10-11-2011	SCALE NTS	DRAWN BY G. BROLATTI	
SHEET SIZE A1	FIRST ANGLE PROJECTION	WBS LEVELS 3	010301
		Drawing Number	503103
		SHEET	03
		REVISION	03
		MATURITY	

Front view
Scale: 1:20

Bottom view
Scale: 1:20

Section A-A
Scale: 1:5

Section A-A
Scale: 1:5

DIMENSIONS RELATE TO ROOM TEMPERATURE (293K)

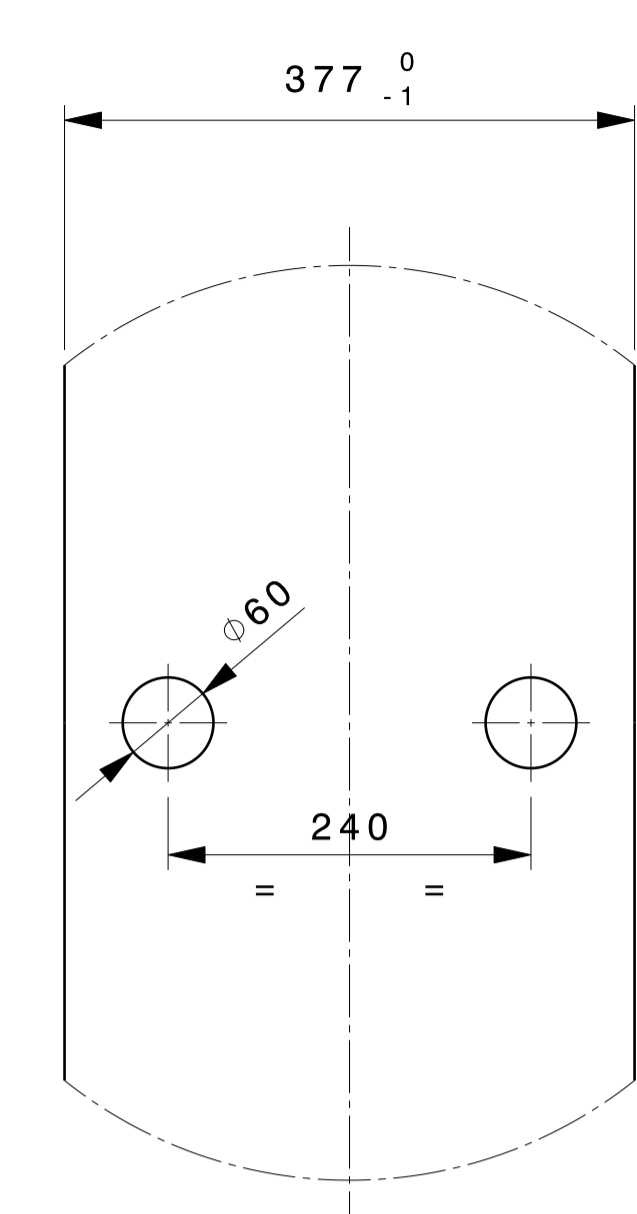
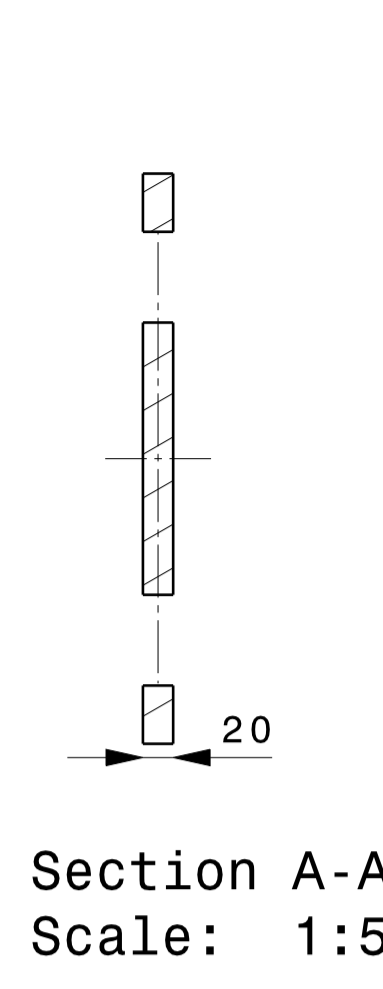
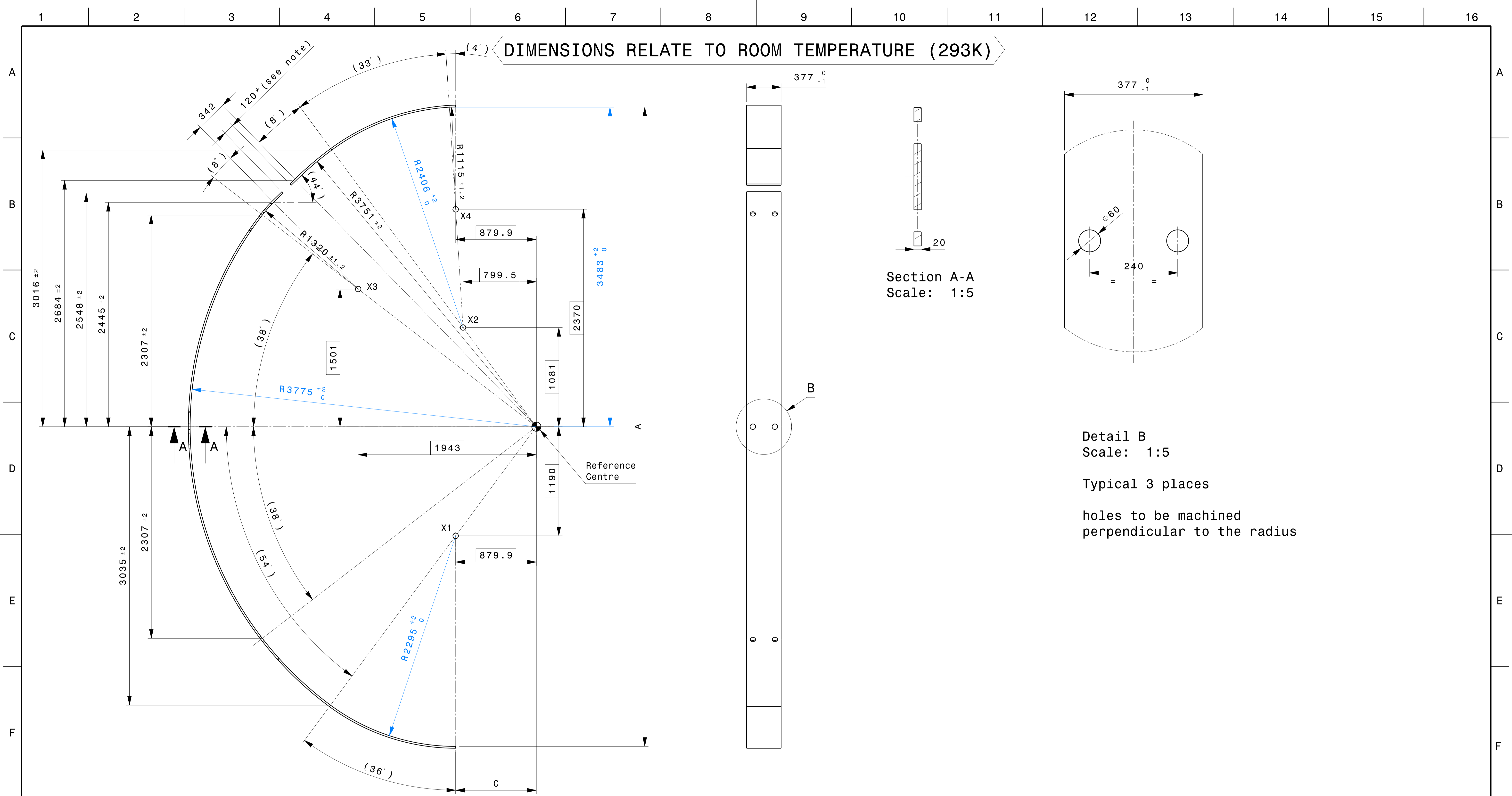

Typical 3 places
holes to be machined
perpendicular to the radius

Front view
Scale: 1:20

Left view
Scale: 1:20

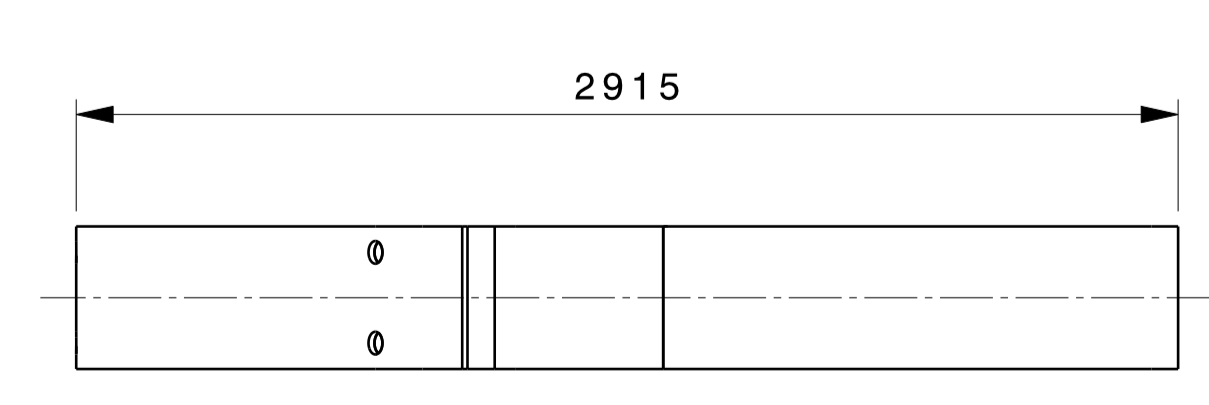

Top view
Scale: 1:20

Note:
-DIN ISO 2768-1 & 2768-2 general medium tolerance class for all machining unless otherwise specified
-For dimension A see drawing 010301 503002
-For dimension C see drawing 010301 503002
-X1, X2, X3, X4 are the centre points of the radii
-For machining of all inner surfaces radii must blend
* make the piece whole, ALSTOM will perform the cut at a later time
-APPLY ROUGHNESS Ra 3.2 UNLESS OTHERWISE SPECIFIED

DRAWING FOR ALSTOM

FOR CONTRACT		ref. to 3D CatProduct: 010301-203004	
<small>CONFIDENTIAL UNLESS AUTHORISED</small> The information on this drawing is confidential under the terms of the BA agreement. This information shall not be transmitted to anyone who is not authorised to receive it.	APPROVED BY A. CUCCHIARO	Fusion Italy-Frascati Research Centre	CUSTOMER: Fusion-for-Energy
	REVIEWED BY		DRAWING TITLE Curved Leg Inboard Toroidal Field Coil
REV DATE 18-06-2012	CHECKED BY	CONTROLLED BY G.M. POLLI	CODE ENEA ID: DD-JT60TF-NCO
FIRST ISSUE DATE 10-11-2011	SCALE NTS	DRAWN BY G. BROLATTI	
SHEET SIZE A1	FIRST ANGLE PROJECTION	WBS LEVELS 3	010301 Drawing Number
			503104 SHEET
			01 REVISION
			03 MATURITY

DIMENSIONS RELATE TO ROOM TEMPERATURE (293K)

Section cut C-C
Scale: 1:2

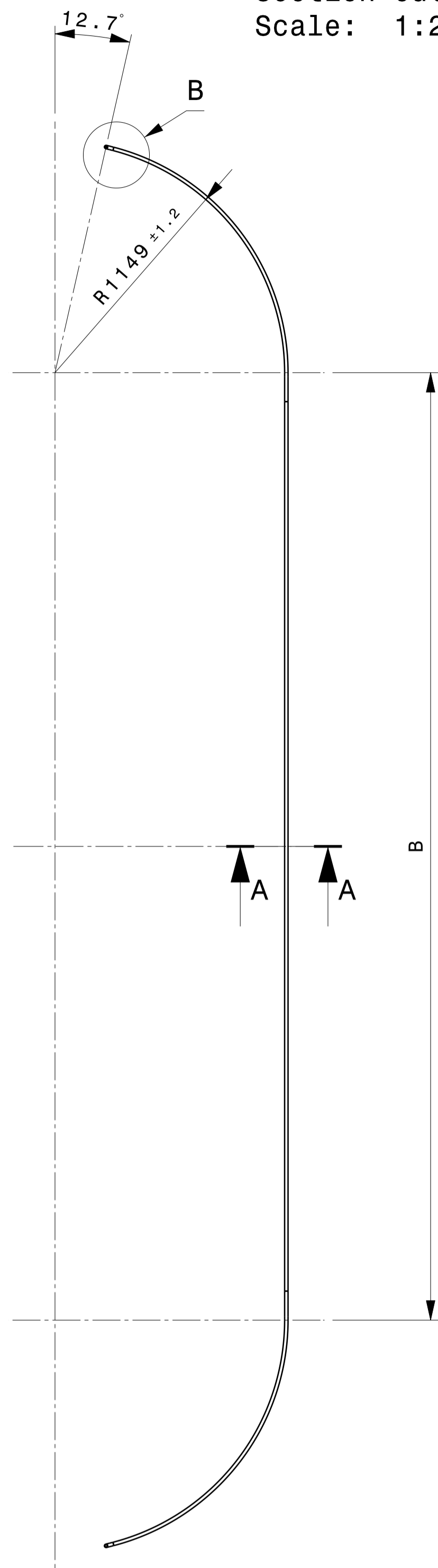

Front view
Scale: 1:20

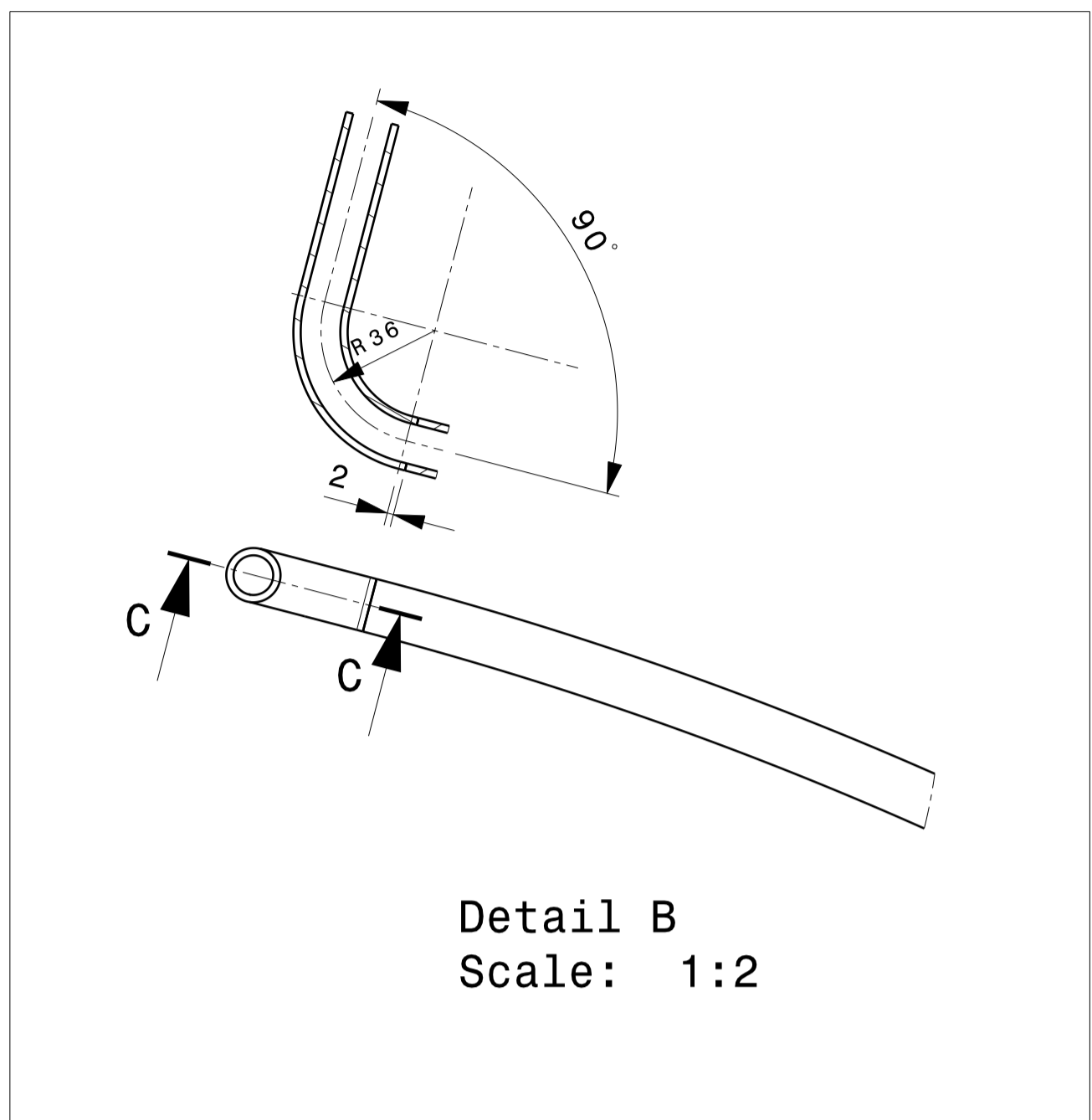

Detail B
Scale: 1:2

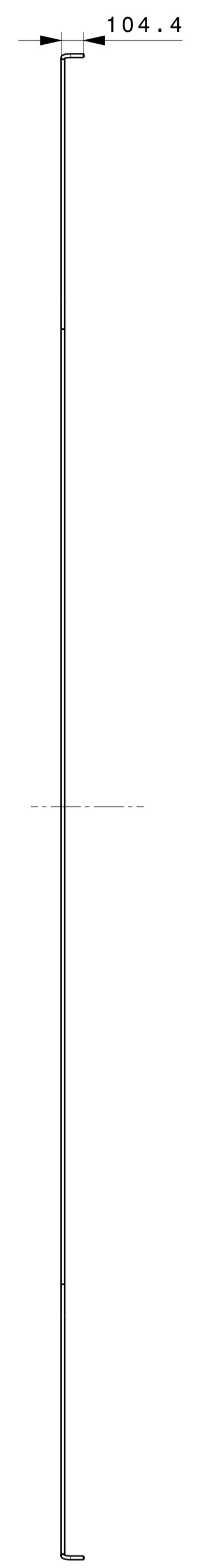

Left view
Scale: 1:20

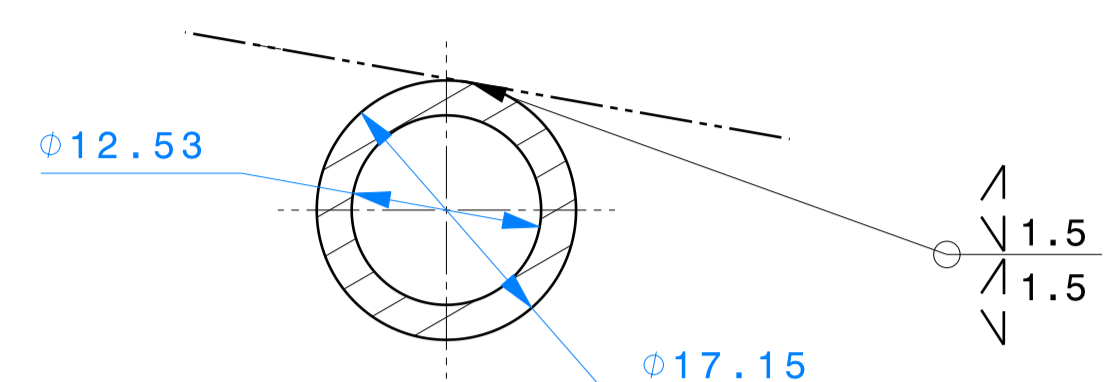

Section A-A
Scale: 2:1

reinforced butt weld 1.5mm

Note:

- DIN ISO 2768-1 & 2768-2 general medium tolerance class for all machining unless otherwise specified
- For dimension B see drawing 010301 503002
- No trapped air volume is allowed between the cooling channel and the coil casing

-total length of the tube about 8m

-APPLY ROUGHNESS Ra 3.2 UNLESS OTHERWISE SPECIFIED

DRAWING FOR ALSTOM

FOR CONTRACT				ref. to 3D CatProduct: 010301-203006			
CONFIDENTIAL UNLESS AUTHORISED <small>The information on this drawing is confidential under the terms of the BA agreement. This information shall not be transmitted to anyone who is not authorised to receive it.</small>		APPROVED BY A. CUCCHIARO		 Fusion <small>Italy-Frascati Research Centre</small>		CUSTOMER: Fusion-for-Energy	
		REVIEWED BY				DRAWING TITLE Inner He Cooling Layout Toroidal Field Coil	
REV DATE 18-06-2012		CHECKED BY		DRAWING TITLE		CUSTOMER	
FIRST ISSUE DATE 10-11-2011		SCALE NTS		CONTROLLED BY G.M. POLLI		CODE ENEA ID: DD-JT60TF-NCO	
SHEET SIZE A1		FIRST ANGLE PROJECTION		WBS LEVELS 3		DRAWING NUMBER 010301	
				SHEET NUMBER 503106		SHEET REVISION MATURITY 01 / 02	