



Agenzia nazionale per le nuove tecnologie, l'energia  
e lo sviluppo economico sostenibile



*Ministero dello Sviluppo Economico*

## RICERCA DI SISTEMA ELETTRICO

Fornitura di 4 sistemi di commutazione Switching Network Unit per la  
macchina sperimentale tokamak JT-60SA

*A. Lampasi, G. Maffia, F. Starace*



FORNITURA DI 4 SISTEMI DI COMMUTAZIONE SWITCHING NETWORK UNIT PER LA MACCHINA  
SPERIMENTALE TOKAMAK JT-60SA

A. Lampasi, G. Maffia, F. Starace (ENEA)

Settembre 2012

Report Ricerca di Sistema Elettrico

Accordo di Programma Ministero dello Sviluppo Economico - ENEA

Area: Governo, gestione e sviluppo del sistema elettrico nazionale

Progetto: Fusione nucleare: Attività di fisica e tecnologia della fusione complementari ad ITER

Responsabile del Progetto: Aldo Pizzuto, ENEA

## Indice

<b>Sommario .....</b>	<b>8</b>
<i>Introduzione .....</i>	<i>9</i>
<b>Descrizione delle attività svolte e risultati .....</b>	<b>9</b>
<i>Scope of the Procurement .....</i>	<i>9</i>
<i>Warranty .....</i>	<i>10</i>
<i>Functional description of the JT-60SA power supply system .....</i>	<i>10</i>
<i>Other coil power supplies (only for information).....</i>	<i>14</i>
<i>SNU specifications and requirements.....</i>	<i>15</i>
<i>SNU basic scope.....</i>	<i>15</i>
<i>SNU functional parameters and operating mode.....</i>	<i>17</i>
<i>Control strategy.....</i>	<i>17</i>
<i>SNU cooling system .....</i>	<i>21</i>
<i>Layout and installation requirements .....</i>	<i>22</i>
<i>Enclosures.....</i>	<i>22</i>
<i>Interfaces.....</i>	<i>24</i>
<i>Interface with the DC power and the coil.....</i>	<i>24</i>
<i>Interface with the low voltage distribution system .....</i>	<i>24</i>
<i>Interfaces with the fluids systems .....</i>	<i>25</i>
<i>Interface with the grounding grid .....</i>	<i>25</i>
<i>Interfaces with the building.....</i>	<i>25</i>
<i>Interfaces with PS SC, SCSDAS, GPS and SIS .....</i>	<i>26</i>
<i>SNU reference scheme.....</i>	<i>26</i>
<i>Typical operation sequence of the reference scheme .....</i>	<i>27</i>
<i>By-pass switch (BPS).....</i>	<i>28</i>
<i>Static circuit breaker (SCB) .....</i>	<i>30</i>
<i>Breakdown resistors .....</i>	<i>30</i>
<i>Power connections .....</i>	<i>31</i>
<i>Grounding connections.....</i>	<i>31</i>
<i>Safety grounding switches.....</i>	<i>31</i>
<i>Design and construction .....</i>	<i>31</i>
<i>Seismic design .....</i>	<i>31</i>
<i>Transmission and insulation signals.....</i>	<i>31</i>

<i>Cables and optical fibres</i> .....	32
<i>Use of oil and combustible materials</i> .....	32
<i>Audible noise</i> .....	32
<i>Access to the equipment</i> .....	32
<i>Spare parts</i> .....	32
<i>General testing and approval requirements</i> .....	33
<i>Factory Type Tests</i> .....	33
<i>Specific Factory Type Tests for the BPS</i> .....	33
<i>Test to verify the I<sup>2</sup>t capability and the unbalance of the BPS</i> .....	33
<i>Test to verify the electro-dynamic resistance of the BPS</i> .....	34
<i>Test to verify the opening and closing mechanisms</i> .....	34
<i>Test to verify the pressure withstand and the tightness for gas-filled compartments</i> .....	34
<i>Tests on the prototype SNU</i> .....	34
<i>Operational tests at reduced current and reduced voltage</i> .....	34
<i>Operational tests at reduced current and nominal voltage</i> .....	34
<i>Operational tests at nominal current and nominal voltage</i> .....	35
<i>Tests to verify the breakdown resistors</i> .....	35
<i>Functional tests to check the protection system</i> .....	35
<i>Factory Routine Tests</i> .....	35
<i>Factory Routine Tests on the BPS</i> .....	35
<i>Voltage to ground withstand tests (main circuit)</i> .....	35
<i>Voltage to ground withstand tests (auxiliary and control circuits)</i> .....	36
<i>Mechanical operating tests</i> .....	36
<i>Design and visual check</i> .....	36
<i>Factory Routine Tests on the SCB and MS</i> .....	36
<i>Visual and electrical check</i> .....	36
<i>Voltage to ground withstand tests (main circuit)</i> .....	36
<i>Voltage to ground withstand tests (auxiliary and control circuits)</i> .....	36
<i>Tests on the SCB and MS operational timing</i> .....	36
<i>Tests on breakdown resistors</i> .....	36
<i>Measurement of the nominal resistance</i> .....	36
<i>Voltage to ground withstand tests</i> .....	36
<i>Tests on grounding switches</i> .....	36
<i>Voltage to ground withstand tests (main circuit)</i> .....	36
<i>Voltage to ground withstand tests (auxiliary and control circuits)</i> .....	36
<i>Mechanical operating tests</i> .....	37
<i>Design and visual check</i> .....	37
<i>Tests on the SNU LCC</i> .....	37

<i>Insulation to ground tests</i> .....	37
<i>Functional tests</i> .....	37
<i>Tests on current and voltage transducers</i> .....	37
<i>Tests on electrical and optical fiber cables</i> .....	37
<i>Tests on water cooling and compressed air systems</i> .....	37
<i>EMC/Immunity compliance</i> .....	37
<i>Site Acceptance Tests</i> .....	37
<i>Tests to verify the voltage to ground insulation</i> .....	37
<i>Functional tests on the control, protection and measurement systems</i> .....	37
<i>Functional tests on the connections to the auxiliary systems</i> .....	38
<i>Tests to check the connection of the breakdown resistors</i> .....	38
<i>Packing and transport requirements</i> .....	38
<i>Packaging</i> .....	38
<i>Inspection of the packaging prior to the shipment</i> .....	38
<i>Handling and storage</i> .....	38
<i>Delivery state</i> .....	38
<i>Transports</i> .....	39
<i>Check of the packaging appearance at the PoE</i> .....	39
<i>Identification and traceability requirements</i> .....	39
<i>Documentation to be supplied</i> .....	39
<i>Industrial Supplier Quality Plan</i> .....	39
<i>Progress reports</i> .....	39
<i>Technical documentation</i> .....	39
<i>First Design Report</i> .....	40
<i>Factory test plan and procedures</i> .....	40
<i>Site Installation Plan</i> .....	40
<i>Site Commissioning Program</i> .....	40
<i>Test reports</i> .....	41
<i>Operation and Maintenance Manual</i> .....	41
<i>Specifications for non-standard components</i> .....	41
<i>Block and functional schemes of the control system</i> .....	41
<i>Final Design Report</i> .....	41
<i>Drawings</i> .....	41
<i>Source code</i> .....	41
<i>Import documents</i> .....	41
<i>Training</i> .....	41
<i>Ambient conditions</i> .....	42
<i>Drawings</i> .....	43

<i>Management and Quality Specifications</i> .....	48
<i>Scope of the Management and Quality Specifications (MQS)</i> .....	48
<i>Contract phases, deliverables and deadlines</i> .....	48
<i>ENEA responsibilities</i> .....	49
<i>ISQP requirements</i> .....	49
<i>Objectives and deliverables of the Contract</i> .....	50
<i>Responsibilities requirements</i> .....	50
<i>Contract management</i> .....	50
<i>Work Breakdown Structure (WBS)</i> .....	51
<i>Industrial Supplier Control Plan (ISCP)</i> .....	51
<i>Time schedule management</i> .....	51
<i>Resource management</i> .....	51
<i>Qualification for special processes</i> .....	52
<i>Staff qualification</i> .....	52
<i>Material resources</i> .....	52
<i>Management of nonconformities and deviations</i> .....	52
<i>Management of deviations</i> .....	52
<i>Deviation Request originating from IS or subcontractors</i> .....	52
<i>Deviation Request originating from ENEA</i> .....	53
<i>Management of nonconformities</i> .....	53
<i>Records management</i> .....	53
<i>Information and documentation management</i> .....	54
<i>Drawing control</i> .....	54
<i>Subcontracting management</i> .....	54
<i>Assessment and validation management</i> .....	55
<i>Measuring and test equipment</i> .....	55
<i>Acceptance and delivery requirements</i> .....	55
<i>IS review of the acceptance data packages and IS release note</i> .....	55
<i>Acceptance of deliverables</i> .....	56
<i>Contract risk management</i> .....	56
<i>Health &amp; safety</i> .....	56
<i>Codes, regulatory documents and standards</i> .....	56
<i>Evolution and revisions of the ISQP</i> .....	56
<i>ISQP at tender/proposal level</i> .....	56
<i>ISQP at contract level</i> .....	57
<i>ISQP at test level</i> .....	57
<i>Visits, inspections and audits</i> .....	57
<i>Audits and surveillance</i> .....	57

<i>Access of ENEA observers</i> .....	57
<i>Third party inspection authority</i> .....	57
<i>Summary of Contract documentation</i> .....	58
<i>ISQP</i> .....	58
<i>Progress Reports and Meeting Minutes</i> .....	58
<i>First Design Report</i> .....	58
<i>Factory test plan and procedures</i> .....	59
<i>Site Installation Plan</i> .....	59
<i>Site Commissioning Program</i> .....	59
<i>Test reports</i> .....	59
<i>Operation and maintenance manual</i> .....	59
<i>Specifications for non-standard component</i> .....	60
<i>Block and functional schemes of the control system</i> .....	60
<i>Drawings</i> .....	60
<i>Source code</i> .....	60
<i>Import documents</i> .....	60
<i>Final documentation</i> .....	60
<i>Document format</i> .....	60
<i>Summary of Contract activities</i> .....	61
<i>Stato del Contratto di fornitura degli SNU</i> .....	64
<b>Conclusioni</b> .....	<b>65</b>
<b>Riferimenti bibliografici</b> .....	<b>65</b>
<b>Abbreviazioni ed acronimi</b> .....	<b>66</b>

## Sommario

Il presente rapporto descrive le attività svolte nell'ambito della Ricerca di Sistema Elettrico per il Piano Annuale di Realizzazione (PAR) 2011 dell'Obiettivo A.3 (Progettazione degli "switching network unit") dell'Accordo di Programma tra Ministero dello Sviluppo Economico ed ENEA (Area: Governo, gestione e sviluppo del sistema elettrico nazionale. Progetto: Fusione nucleare: Attività di fisica e tecnologia della fusione complementari ad ITER).

JT-60SA è un progetto "satellite" frutto della collaborazione tra Unione Europea e Giappone nell'ambito dell'accordo internazionale denominato Broader Approach (BA), la cui finalità principale è di fornire indicazioni utili per lo sviluppo e le operazioni dei progetti internazionali ITER e DEMO per lo sfruttamento della fusione nucleare per la produzione di energia. Il tokamak JT-60SA è un aggiornamento superconduttore ("super, advanced") del preesistente tokamak denominato JT-60, situato a Naka in Giappone e gestito dall'agenzia Japan Atomic Energy Agency (JAEA). L'accordo BA stabilisce che alcune nazioni europee, tra cui l'Italia, contribuiscono "volontariamente" (Voluntary Contributor, VC) alle tecnologie ed agli esperimenti di JT-60SA. Ogni contributo al sistema è regolato da un Agreement of Collaboration (AoC) tra l'agenzia europea Fusion for Energy (F4E) e le agenzie nazionali associate (tra cui l'ENEA) finalizzato all'attuazione congiunta di un Procurement Arrangement (PA).

In questo scenario, l'ENEA ha il compito di fornire 4 switching network unit (SNU) per gli alimentatori dei 4 solenoidi centrali (CS) del tokamak JT-60SA situato a Naka in Giappone. Lo scopo principale delle attività presentate in questo rapporto consiste nella realizzazione di questo compito.

Gli SNU giocano un ruolo fondamentale negli esperimenti sul plasma finalizzati alla fusione nucleare. In principio, uno SNU può essere visto come un interruttore per la corrente continua che inserisce molto rapidamente un resistore nel circuito di alimentazione allo scopo di produrre l'alta tensione necessaria al breakdown ed alla formazione del plasma. È utile rilevare che le prestazioni non comuni richieste agli SNU (in termini di corrente, tensione, tempi di intervento) non possono essere ottenute mediante dispositivi commerciali esistenti e richiedono quindi un progetto specifico basato su configurazioni innovative.

L'ENEA, anche con la collaborazione di F4E e JAEA, ha elaborato le specifiche tecniche (TS) e gli altri documenti necessari alla realizzazione degli SNU, alla integrazione dei sistemi e alla gestione dell'impianto.

Nel presente rapporto saranno riassunti gli avanzamenti del progetto e le decisioni prese durante gli incontri e gli scambi di informazioni con F4E e JAEA. In particolare, saranno riportate quasi integralmente le TS ed i documenti preparati per la gestione in qualità della fornitura e secondo le condizioni del BA.

Sulla base delle specifiche tecniche, degli altri documenti facenti parte del BA e degli scambi di informazioni con F4E e JAEA, l'ENEA ha selezionato un fornitore industriale (Industrial Supplier, IS) per l'esecuzione finale degli SNU.

La maggior parte dei testi presentati sono estratti dai deliverable del progetto redatti in lingua inglese, in quanto destinati alla approvazione o alla lettura dei partner internazionali (F4E e JAEA, ma anche altre istituzioni partecipanti al BA) oppure ai potenziali IS. Tali testi saranno riportati nella versione originale.

## Introduzione

Il lavoro svolto all'interno dell'Accordo di Programma ha come obiettivo la realizzazione degli SNU dei CS del tokamak JT-60SA.

Nel periodo di riferimento (ottobre 2011 – settembre 2012) sono state svolte le seguenti attività:

1. Redazione delle TS definitive per la Call for Tender (approvate anche da F4E e JAEA).
2. Redazione delle specifiche gestionali e di qualità (MQS) per la Call for Tender (approvate anche da F4E).
3. Redazione ed aggiornamento della documentazione richiesta dagli accordi BA, PA e AoC (Procurement Plans, Procurement Schedules, Risk Tables, Periodic Reports, ecc.).
4. Partecipazione agli incontri tecnici e gestionali con i partner internazionali (F4E, JAEA ed altre agenzie ed industrie) per lo scambio di informazioni e l'aggiornamento del progetto.
5. Preparazione dei documenti legali ed amministrativi necessari per lo svolgimento della Call for Tender.
6. Azioni relative al procedimento di gara e all'aggiudicazione della fornitura.
7. Avvio della valutazione dell'offerta tecnica prodotta dalla ditta aggiudicataria.

Le prime sezioni di questo rapporto presentano gli aggiornamenti alle TS per la Call for Tender degli SNU, con particolare riguardo a quelli definiti in questo ultimo anno di attività. Per esempio, sono stati codificati i test che il fornitore IS deve effettuare per la verifica ed il collaudo del prototipo di SNU e delle 3 SNU di serie. Inoltre, insieme ai partner internazionali, sono state definite le interfacce e le condizioni esterne degli SNU all'interno dell'impianto JAEA a Naka.

È importante sottolineare che, a causa della natura sperimentale ed innovativa del sistema, alcune sue caratteristiche, anche non secondarie, sono costantemente oggetto di discussione ed aggiornamento con gli altri membri del progetto JT-60SA.

In seguito, il rapporto presenta le specifiche gestionali e di qualità (Management and Quality Specifications for the ENEA Industrial Supplier, MQS) richieste per la fornitura. Tali specifiche sono state preparate dall'ENEA per l'IS e sono state approvate da F4E.

Si farà appena cenno ad ulteriori documenti emessi durante questo anno (AoC Procurement Plan, PA Procurement Plan, Procurement Schedule, Risk Table, etc.) perché relativi soprattutto alla gestione dei rapporti tra ENEA, F4E e JAEA.

Poiché le specifiche tecniche presentate sono state scritte in esecuzione dell'AoC tra F4E e l'ENEA finalizzato all'attuazione congiunta del PA relativo, esse sono state discusse ed ufficialmente approvate dai partner europei e giapponesi. Proprio perché destinate ad interlocutori stranieri, le specifiche tecniche e i disegni sono stati redatti in lingua inglese e saranno riportate in lingua originale.

Sulla base della suddetta documentazione, l'ENEA ha selezionato un fornitore industriale (IS) per l'esecuzione finale degli SNU. Lo stato del processo di selezione è brevemente illustrato alla fine del rapporto.

## Descrizione delle attività svolte e risultati

### Scope of the Procurement

The technical specifications of this Call for Tender regard the design, manufacturing, factory testing, packaging, transportation to the Port of Entry in Japan (PoE) [3] of the 4 SNUs of the CSs of the new JT-60SA tokamak. These 4 coils are classified as CS1, CS2, CS3 and CS4. The SNU main components included in the present Procurement are listed in Table 1.

The activities at Naka Site, as installation and assembly on site, commissioning and Site Acceptance Tests, are not included in the present Procurement. Nevertheless, they are described in this document and in the references to help the IS in developing the design and the documentation. The IS shall provide a self-consistent documentation containing any information necessary to complete the installation in good conditions and respecting the time schedule.

In addition to the main components of Table 1, the Supply shall also include the following items:

- The draft and the detailed design of the components object of the Supply.
- The manufacturing of the components.

- A basic set of spare parts.
- The tests at the IS’s facilities.
- The packaging of the Supply.
- The delivery of all the components to the PoE in Japan. JAEA will be responsible for transportation from the PoE to Naka Site, including formalities and temporary storage.
- Any special tool and equipment necessary for the operation and maintenance of the equipment included in the Supply (these items shall remain property of JAEA).
- The documentation described in the following.
- The training of the operating staff.

Everything that is not unequivocally included in the technical specifications is excluded. In particular, the SNU interfaces with several systems of the machine (coils’ bus-bars, protection and control systems, cooling system, compressed air, buildings, low voltage auxiliaries power supplies, grounding grid, etc.) are not included in the Procurement.

**Table 1: Main components of the SNUs (see Fig. 5).**

SNU Components	Quantity
Fast SNU switch (SS)	1 for each SNU
Making switch (MS)	1 for each SNU
Breakdown resistors (R1 and R2) with associated selectors	2 sets for each SNU
Grounding switches (GSs)	2 for each SNU
SNU control, protection and measurement system	1 single system for all the 4 SNUs
Cooling and compressed-air (if required) systems, enclosures, internal connections	As many as necessary

**Warranty**

All the components shall have a warranty for defects in the manufacture for a period of two years starting from the acceptance of the components. The warranty is limited to the direct costs of repair or remanufacturing of the components. Any other warranty is excluded.

Some extensions could be requested by the Customer.

**Functional description of the JT-60SA power supply system**

This section provides a short description of the JT-60SA power supply (PS) systems in order to introduce and identify the SNU functions and features. Such PS systems are widely addressed in the Section 2.7 of the PID [2]. The PID might be updated during the Contract period. The Customer shall inform the IS about PID changes relevant for this Procurement and an agreement between the Customer and the IS shall be taken on how to cope with these changes.

The JT-60SA PS system mainly consists of:

1. The PSs for the superconducting coils;
2. The PSs for the Fast Plasma Position Control (FPPC) normal conductor coils;
3. The PSs for the additional heating systems, as the positive (P-NBI) and negative (N-NBI) neutral beam injectors and the Electron Cyclotron RF (ECRF) system.

As a common understanding for design of the magnet power supplies of JT-60SA, the presently available JT-60U equipment shall be reused as much as possible.

Fig. 1 shows a schematic diagram of the AC PS system for JT-60SA at Naka Fusion Institute (Japan). The figure corresponds with Fig. 2.7-1 of the PID [2].

The new PS systems will be designed and manufactured to feed the superconducting toroidal field (TF) and poloidal field (PF) coils.

The ECRF system (41 MW for 100 s plasma heating) will be connected to the 275 kV commercial power grid. The P-NBI (60 MW power demand), N-NBI (40 MW power demand) and PF coil PSs will be connected to two existing motor generators (215 MVA / 4.0 GJ, 400 MVA / 2.6 GJ).

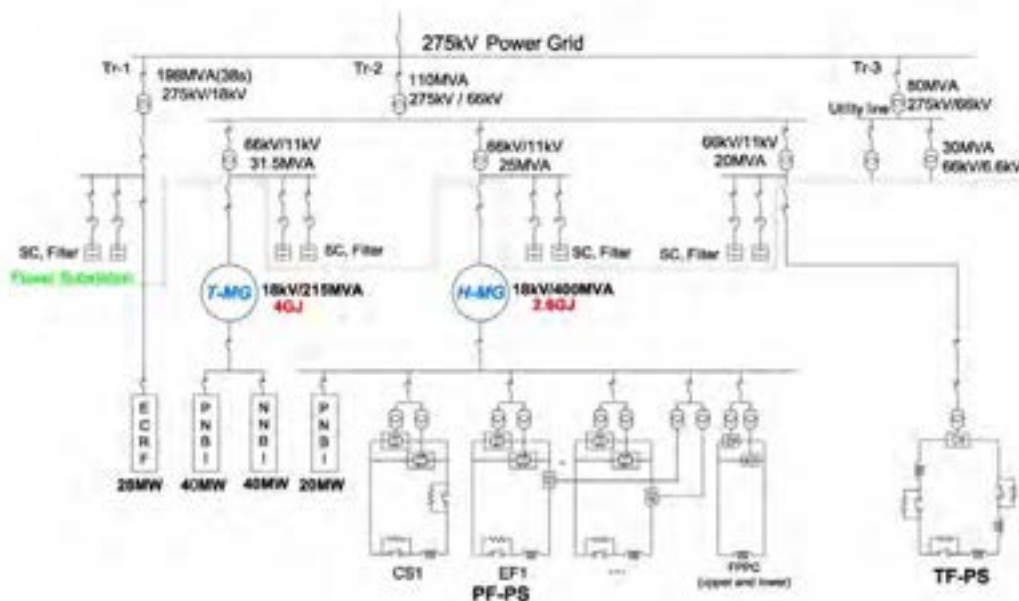

Fig. 1: Schematic diagram of the AC PS for JT-60SA [2].

The PF coil PS shall provide a bipolar DC current adequate to achieve the required scenarios. The existing JT-60 TF transformers will be re-used for 8 of the CS and equilibrium field (EF) PSs as they result compatible with the scenarios. The basic circuit components are a Base PS, a Booster PS and a SNU.

It is planned to re-use the existing vertical field coil PS (PSV) as a Booster PS.

The SNU is added into each CS PS and into the EF3 and EF4 PS to produce the high voltage necessary for the plasma breakdown and plasma current ramp-up. In principle, the SNU consists of DC current interrupters and tunable resistors, as described in the following.

Fig. 2 shows the schematics of the DC circuits for the CS1-4 PSs. As shown in the schemes, the Base PS includes the power transformers, the thyristor converters and the crow-bar switch.

The current reversing links (CRLs) are inserted in the CS and EF coil PSs to allow plasma operations with a reversal in the polarity of the toroidal magnetic field.

In case of a quench of a superconducting coil or of a failure in the PS, the magnetic energy stored in the coil must be rapidly extracted in order to protect the conductor and to shut down the plasma operation.

For this purpose, a quench protection circuit (QPC) consisting of a DC current interrupter, a dump resistor and a Pyrobreaker for back-up protection has to be provided for each superconducting coil. The SNU (and the Booster) shall be by-passed in case of operation of the related QPC to avoid overvoltages on the coil [2]. The QPC is not included in this Procurement.

Table 2 shows the basic specifications of the Base PSs, Booster PSs and SNUs for the CS 1-4 and EF 1-6 coil PSs, as reported in Table 2.7-6 of the PID [2].

Fig. 3 sketches a time diagram of CS current in which the different phases of the coil current are emphasized. The numerical values and the current diagram are reported in the figure only to clarify the SNU operational sequence. Generally, the current scenarios of a tokamak have a first phase (see Fig. 3) where the current ramps up (supplied by the Base PS) until a maximum value. Once this maximum value is reached, a sudden decrease of the current is triggered by inserting a resistor or a Booster PS in order to produce the plasma current breakdown. Fig. 3 also shows a zoom of the breakdown phase: in the JT-60SA CS1-4 and EF3-4, the sharp current variation required at the breakdown shall be realized by SNUs.

The SNU is purposely designed to insert a suitable resistor in series with the coil circuits, just immediately before the plasma breakdown. The sharp change in the coil current derivative induces a voltage in the plasma that triggers its ramp-up.

After the plasma start, there is a second phase of the scenario in which the SNU resistance generally needs to be changed in order to follow the scenario current reference. When the plasma current exceeds a prefixed value, the SNU short-circuits the resistor(s) to exclude it from the power circuit.

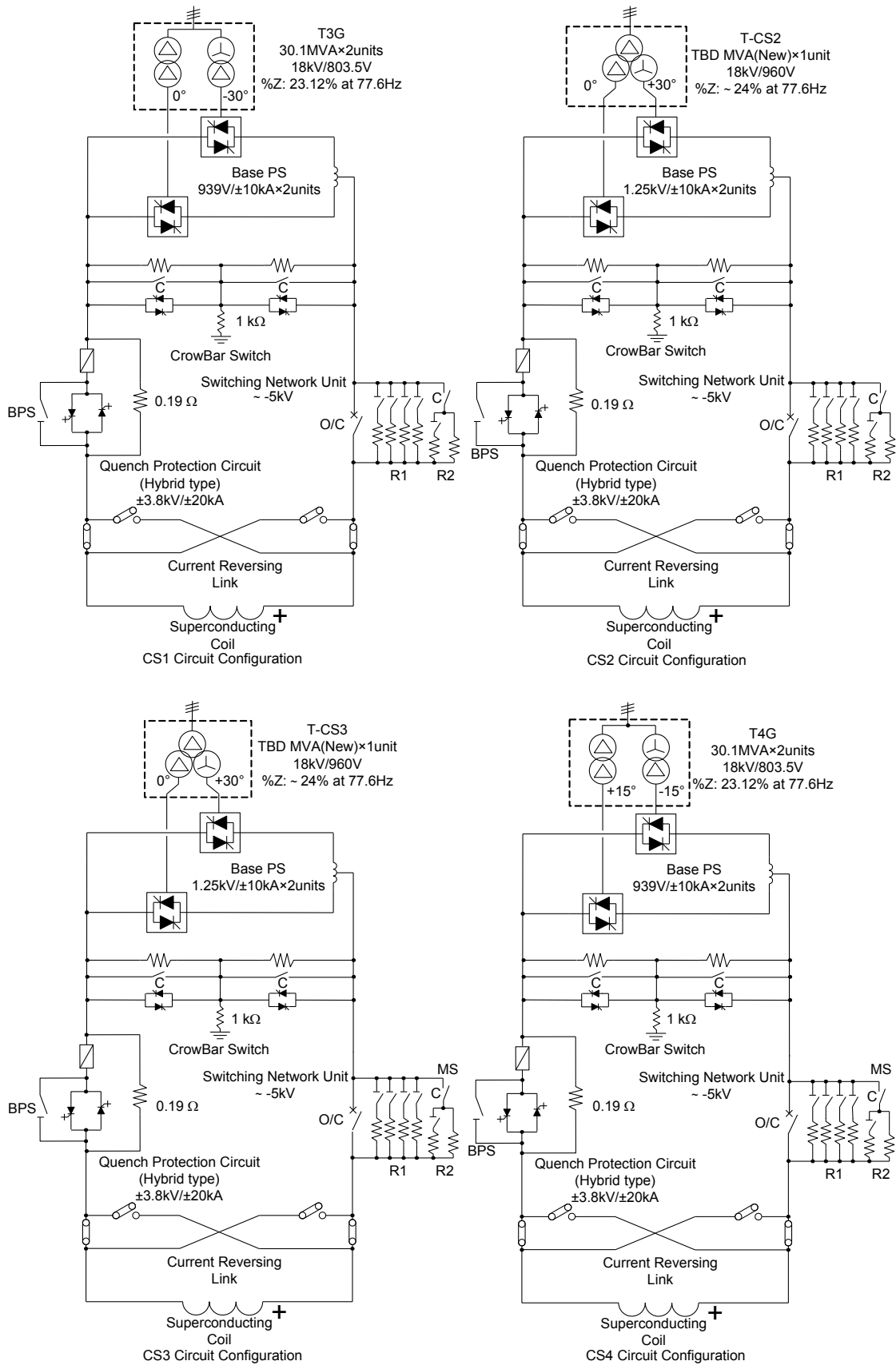

Fig. 2: CS1-4 PS circuit configuration (see Fig. 2.7-3 of the PID [2]).

**Table 2: Specifications for Base/Booster PSs and SNUs for CS1-4 and EF1-6 [2].**

	BASE PS (1)(2)(3)(8) (duty cycle: 220s/1800s)				BOOSTER PS(5) (short time rating)						SNU (kV) Repetition time 1800s (7) (9)		
					Forward			Reverse					
	XFMR $U_{10\text{ rms}}=18\text{kV}$		$V_{\text{dc0}}$ (kV)	$I_{\text{dc}}$ (kA)	XFMR $U_{10\text{ rms}}=18\text{kV}$		$V_{\text{dc0}}$ (kV)	$I_{\text{dc}}$ (kA)	XFMR $U_{10\text{ rms}}=18\text{kV}$			$V_{\text{dc0}}$ (kV)	$I_{\text{dc}}$ (kA)
	$U_{20\text{ rms}}$ (kV)	Z% (4)			$U_{20\text{ rms}}$ (kV)	Z% (4)			$U_{20\text{ rms}}$ (kV)	Z% (4)			
CS1	0.8 <sup>(6)</sup>	23	1.0	$\pm 2*10$									-5.0
CS2	0.96	24	1.25	$\pm 2*10$									-5.0
CS3	0.96	24	1.25	$\pm 2*10$									-5.0
CS4	0.8 <sup>(6)</sup>	23	1.0	$\pm 2*10$									-5.0
EF1	0.8 <sup>(6)</sup>	23	1.0	$\pm 1*10$	2.9				3.16				
	0.8 <sup>(6)</sup>	23	1.0	$-1*10$	+	24	7.8	+4	+	24	7.1	-14.5	
EF2	0.72 <sup>(6)</sup>	18	0.97	$\pm 2*5$	2.9				3.16				
	0.72 <sup>(6)</sup>	18	0.97	$-2*5$	+	24	7.8	+4	+	24	7.1	-14.5	
EF3	0.72 <sup>(6)</sup>	18	0.97	$\pm 4*5$									-5.0
EF4	0.72 <sup>(6)</sup>	18	0.97	$\pm 4*5$									-5.0
EF5	0.72 <sup>(6)</sup>	18	0.97	$\pm 2*5$	2.9				3.16				
	0.72 <sup>(6)</sup>	18	0.97	$-2*5$	+	24	7.8	+4	+	24	7.1	-14.5	
EF6	0.8 <sup>(6)</sup>	23	1.0	$\pm 1*10$	2.9				3.16				
	0.8 <sup>(6)</sup>	23	1.0	$-1*10$	+	24	7.8	+4	+	24	7.1	-14.5	

**NOTE :**

(1) Back-to-back four quadrants (with circulation current), 12 pulses (6 pulses during circulation current operation), demineralised water cooled converters including crow-bar unit. For each 12-pulses converter the following demi-water cooling main characteristics are needed (to be confirmed):

- $Q = 24 \text{ m}^3/\text{h}$
- $T_{\text{in}} \leq 35 \text{ }^\circ\text{C}$
- $\Delta T_{\text{in,out}} = 10 \text{ }^\circ\text{C}$
- $P_{\text{in}} = 450 \text{ kPa}$
- $\Delta P_{\text{in,out}} = 250 \text{ kPa}$
- $\rho \geq 1 \text{ M}\Omega\cdot\text{cm}$

(2) Insulating voltage to ground :  $U_M = 9 \text{ kV}$  (ref. IEC 146-1-1 sections 4.2.1.3 and 4.2.1.4, where factory test voltage is defined as  $V_{\text{test}} = 4 + 1.8U_M/1.41$  and  $U_M$  is defined as "highest crest voltage".)

(3) DC current accuracy (%) =  $\pm 1\%$  of nominal value

(4) Tentative values referred to XFMR power at secondary side, at 77.6Hz

(5) Two quadrants converters

(6) Already existing XFMR

(7) Reference highest voltage for equipment (IEC 60071) = 7.2 kVrms

(8) Reverse-side converters for EF1, EF2, EF5, and EF6 have two quadrants (with circulation current).

(9) For each SNU unit a cooling water flow  $Q = 6 \text{ m}^3/\text{h}$  is requested. In principle raw water is acceptable, if available otherwise demineralised water should be provided.

The specification of inter-phase reactor shall be defined to be compatible to the thyristor converter and transformers.

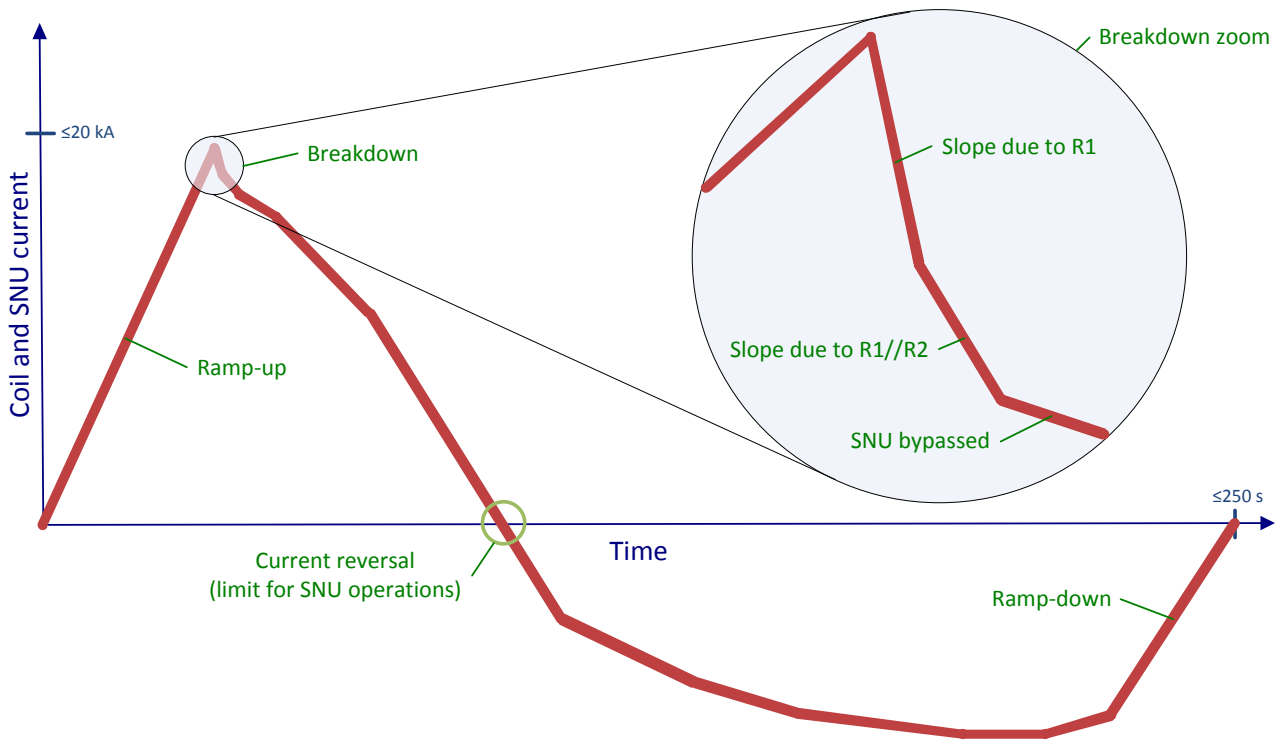

Fig. 3: Example of CS current scenario with a zoom of the breakdown phase to emphasize the effect of the SNU operations.

*Other coil power supplies (only for information)*

The EF coil PSs are basically based on the same principles presented for the CS PSs.

The circuit for the TF coil PS is shown in Fig. 4, corresponding with Fig. 2.7-2 of the PID [2]. The 11 kV network provides the AC source voltage of the TF coil PS.

The TF coil PS shall be able to provide the required 25.7 kA DC current continuously to the superconducting TF coils. The nominal DC voltage shall be sufficient to charge or discharge the full current within about 20 minutes. Typical operation of the TF coil PS is that the TF coils are energized every day in the morning before the starting of the plasma experiments and demagnetized after the experimental period.

The set of the JT-60SA PSs is completed by the PSs for upper/lower FPPC coils, for Resistive Wall Mode (RWM) suppression and for error field correction.

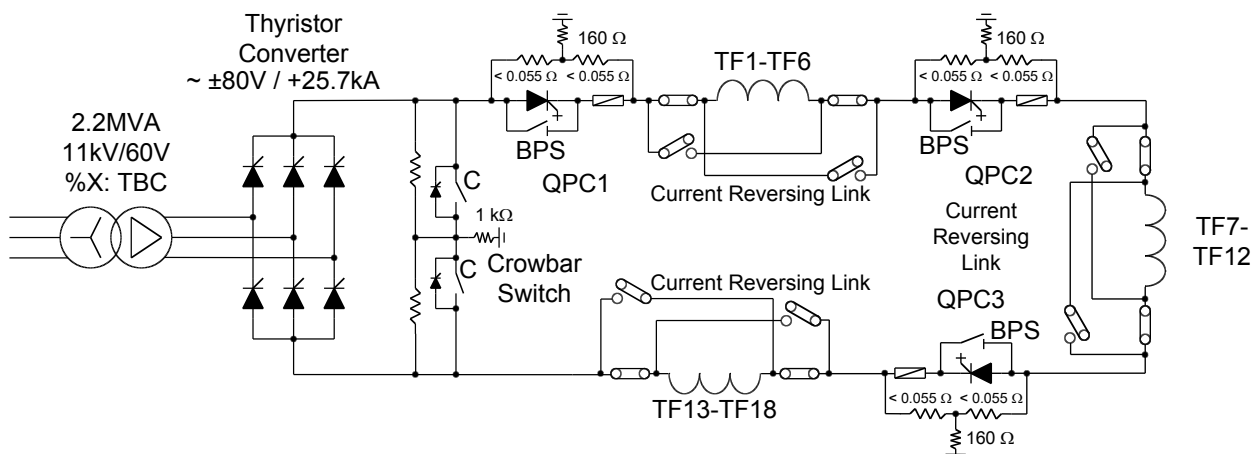

Fig. 4: Schematic of the TF coil circuit configuration [2].

### *SNU specifications and requirements*

The IS must develop his technical proposal in accordance with the functional specifications included in the present document.

The final solution proposed by the IS shall be agreed with the Customer during the Detailed Design Phase (DDP). In any case, the IS shall take upon himself the comprehensive liability on the conformity of the technical proposal to the specifications and to the other documents and references related to the Procurement.

### *SNU basic scope*

The SNU functional scheme is displayed in Fig. 5 (see Fig. 2.7-11 of the PID [2]). The SS has to close and open while the load current is flowing, in order to insert the resistance R1 in the coil circuit. The MS has to insert, during the shot, the resistance R2 that will be in parallel with R1.

The values of the resistance R1 and R2 change according to the resistors pre-inserted in the circuit. The values of the two sets of resistors R1 and R2 are arranged, before the start of the pulse, by the selectors C2, C11, C12, C13 and C14 shown in Fig. 5.

The resistors required for each SNU are shown in Table 3.

Since the voltage drops caused by R1 and R2 are directly proportional to the current amplitudes, different scenarios can be realized by modifying the resistances values. During a single shot it is possible to insert a resistance value for each resistor set R1 and R2, pre-arranged by an opportune combination of the values shown in the Table 3.

Fig. 3 shows a typical current diagram in a tokamak coil with the only purpose to clarify the SNU operational sequence. This sequence is summarized in the following:

1. In the ramp-up phase the Base PS, based on thyristor converters (see Fig. 2), increases the coil current up to a maximum positive value (20 kA). In this phase, the SS is closed and the MS is opened (see Fig. 5).
2. At the breakdown, the SS switches off. Consequently, the current changes over the resistor set R1 and its derivative changes immediately.
3. After some tens of milliseconds, if a smaller current derivative is needed, the MS inserts the resistor set R2 in the coil circuit. The timing accuracies of the SS and MS are particularly critical because strictly related to the plasma start-up.
4. After this phase, and in any case before the possible current reversal, the resistors will be disconnected from the power circuit closing again the SS (the MS can be opened at zero current flowing in its branch).
5. The state of the SNU does not change during the rest of the scenario. The entire scenario can last up to 250 s.

The switching commands for the SS and the MS come from the JT-60SA control systems. As their timing depends on the current scenario around the breakdown, the SNU Local Control Cubicle (LCC) shall check, also, the right sequence (interlocks) of the switching commands (SS opening → MS closing → SS closing).

The SS shall be sized for the nominal current (20 kA) and for the maximum pulse length (250 s). The data in Table 3 fixes also the characteristics of the switches related to the resistors. In particular, since the resistance R2 is inserted by the MS, the MS shall be sized considering the dump energies of the resistors R21 and R22.

The maximum operational voltage and the reference highest voltage for equipment (IEC 60071) are identical for all the resistors and correspond to the maximum values possible in the SNU (see Table 4).

The specifications of the SNU components and systems and their operation mode are described in the following sections.

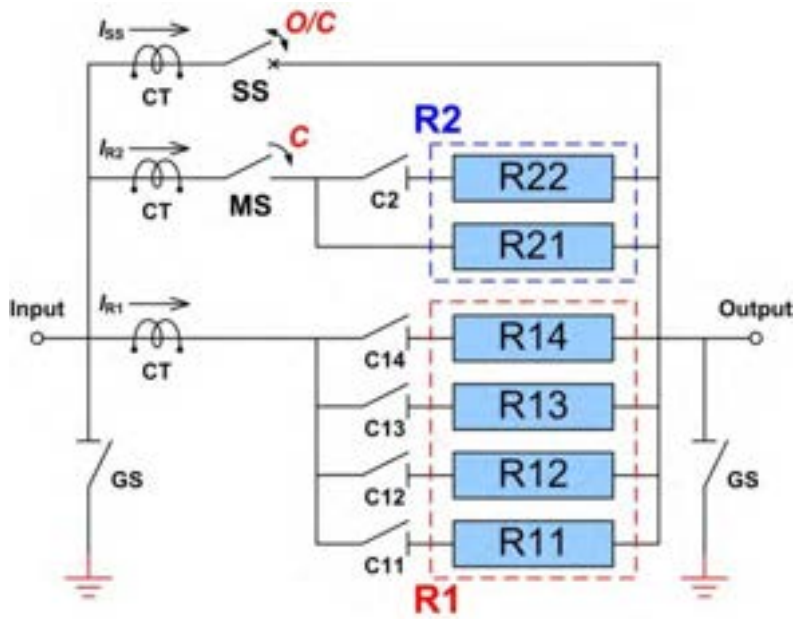

Fig. 5: Functional scheme of the SNU.

Table 3: Characteristics of the SNU resistors.

Item	Resistance	Rated Current	Dump Energy		Max voltage	Voltage (IEC 60071)	
R1	R14	3.75 Ω	1.333 kA	2 MJ		5 kV DC	7.2 kV rms
	R13	1.875 Ω	2.667 kA	4 MJ		5 kV DC	7.2 kV rms
	R12	0.9375 Ω	5.333 kA	8 MJ		5 kV DC	7.2 kV rms
	R11	0.4688 Ω	10.667 kA	16 MJ		5 kV DC	7.2 kV rms
R2	R21	0.05 Ω	10.0 kA	CS1, CS4	CS2, CS3	5 kV DC	7.2 kV rms
				30 MJ	20 MJ		
	R22	0.05 Ω	10.0 kA	CS1, CS4	CS2, CS3	5 kV DC	7.2 kV rms
				30 MJ	20 MJ		

Table 4: Main parameters of the SNU.

SNU Parameter	Value
Nominal current	±20 kA
SS maximum conducting current	±23 kA
SS maximum interrupting current	20 kA
Maximum pulse length	250 s
Minimum repetition time	1800 s
Current interruption	Unidirectional
Rated voltage	5 kV
Maximum transient voltage	7 kV
Reference highest voltage for equipment (IEC 60071)	7.2 kV rms
SS and MS maximum switch-on/off time	≤1 ms
SS operation accuracy/repeatability	≤0.5 ms
MS operation accuracy/repeatability	≤1 ms
SNUs installation	Indoor
Indoor maximum to minimum temperature	40/5 °C
Maximum monthly average relative humidity	87%
Accuracy of each breakdown resistor (at 20°C)	±2%
Maximum variation of resistors with temperature	±10%
Number of operations without maintenance (excluding sacrificial contacts)	10000

### *SNU functional parameters and operating mode*

Table 4 summarizes the main parameters on which the SNU design shall be based, as explained in the following.

The nominal current reported in the table refers to the expected standard operational conditions. In addition, it is necessary to consider that a plasma disruption can induce in the coil current a step increasing of about 2.6 kA.

The repetition time is the time interval between two following experimental pulses (see Table 1.2-1 of the PID [2]). A pulse can last a maximum of 250 s including a maximum initial ramp-up time of 40 s. The JT-60SA working time for the experiments shall be 10 hours per day.

The operations shall be performed except in the case of dew condensation. JAEA will stop the operations in case of risk of dew condensation.

The scenarios included in the PID [2] could be changed during the project. In case of changes, the possible consequent modifications in the SNUs shall be agreed between the Customer and the IS.

All the PF coil PSs are 4-quadrants type, so both the voltage and the current can reverse. As the SNUs operate in a fixed phase of the scenario in which the current direction does not change, the current can be considered unidirectional to the SNU aim. If the inversion of the coil currents is needed, it could be realized by the CRL polarity changers (see Fig. 2). In any case, the SS shall be re-closed before the reversing of the load current.

The rated voltage between the SNU terminals at the breakdown is 5 kV. This voltage shall not overcome 7 kV in any case, including all the possible contributions (transients, commutations, resistance tolerances and temperature variations). As a consequence, in compliance with the Standard IEC 60071, the insulation level of the device should be 7.2 kV rms. In fact, according to the Table 2 in Standard IEC 60071-2, the corresponding standard rated short-duration withstand voltage is 20 kV rms. The value of the maximum transient voltage may be revised during the DDP according to new information provided by JAEA.

The SS operation controls the plasma start-up, so it must be very fast and accurate. In particular, the SS has to switch-off (namely, its current decreases under the 2% of its initial value) in less than 1 ms after the activation of the related command and the accuracy of the timing of the operation must be better or equal to 500  $\mu$ s. Therefore, in the worst-case the SS switch-off time can be 1.5 ms. The same requirements will be assumed for the SS turn on.

If the SS turn on and off commands consist in a sequence of commands, the value for the “Maximum switch on/off time” in Table 4 refers to the final command that inserts or removes the resistors in/from the coil circuit.

The SS shall operate with the time performances reported in Table 4 in the whole operational current range.

The MS switch-on time can be identical to the SS one (1 ms), while the accuracy can be up to 1 ms (worst-case switch-on time 2 ms).

### *Control strategy*

The JT-60SA Supervisory Control System and Data Acquisition System (SCSDAS) is described in Section 2.17 of the PID [2]. The JT-60SA control system will also include a system for handling the protection signals received from the equipment and distribute the protection commands (GPS) and a system for managing the safety interlock signals (SIS). The detailed design of such systems is yet under development.

The JT-60SA PS system will be directly managed by a dedicated Power Supply Supervising Computer (PS SC), provided by JAEA, that communicates with SCSDAS, GPS and SIS. The PS SC includes an Internal Protection System (IPS) that coordinates protective actions among all JT-60SA PS components and among them and the remaining parts of the JT-60SA system.

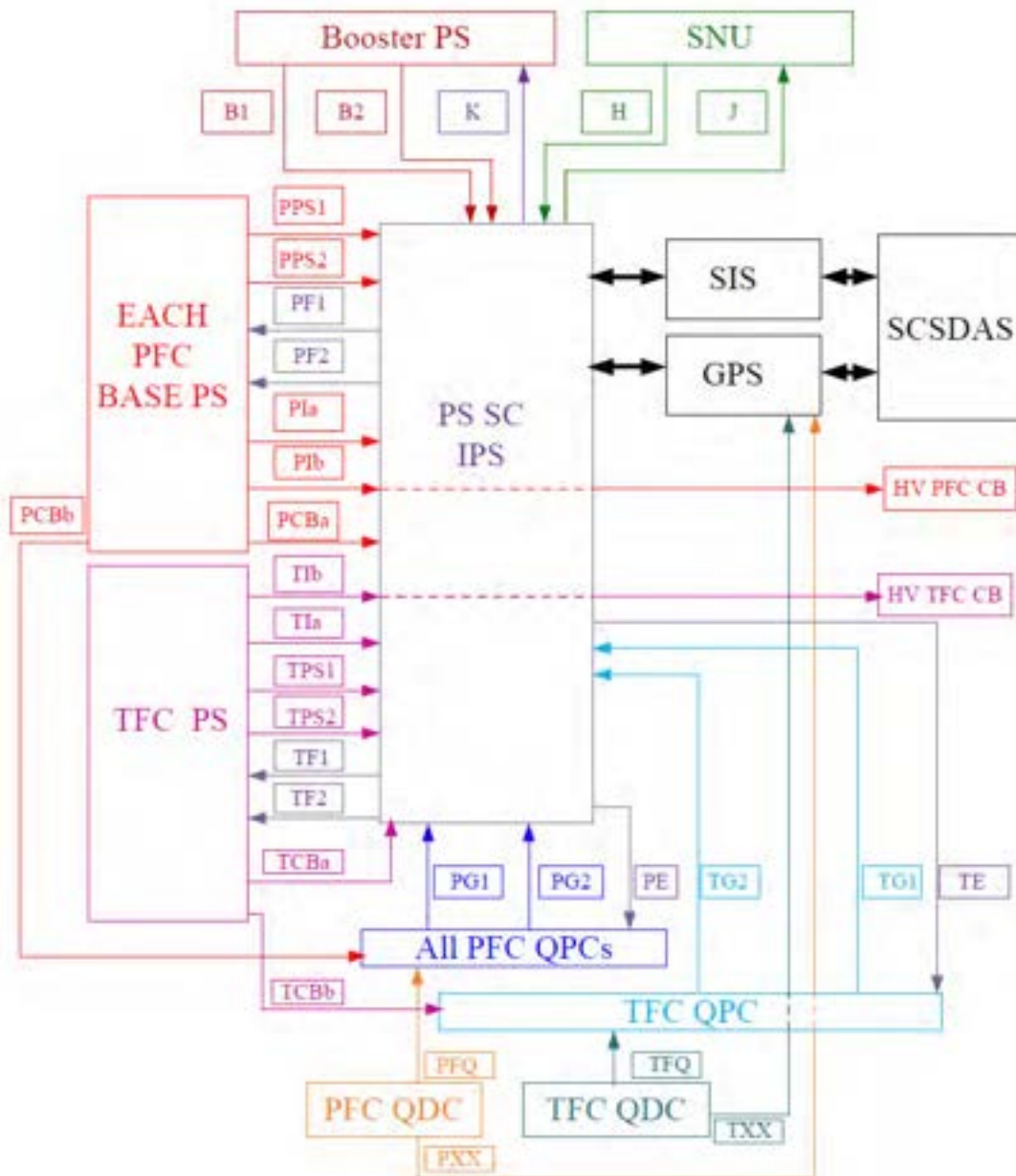

Fig. 6: General diagram of the protection signals of the JT-60SA PS system [11].

The SNU Procurement includes a dedicated LCC with functions of control, backup, protection, interface and information. The LCC hardware essentially consists of a central unit based on PLC or industrial PC devices and of a set of interfaces towards the SNUs and the human-machine interface (HMI). The HMI hardware shall contain an LCD screen with touch commands or keyboard to display and control friendly high-level panels, possibly including graphic mimics of the devices.

The SNU LCC is connected to the PS SC that can communicate with the rest of the JT-60SA plant, as sketched in Fig. 6 that coincides with Fig. 3.2 of [11]: “H” is a protection signal used by the SNU LCC to inform the IPS that an internal fault, requesting an action, occurred in one SNU, “J” is a protection command used by the IPS to prevent the operation of all the SNUs [11].

Each SNU can operate either in local control mode (LCM) or in remote control mode (RCM), depending on the state of a key selector placed on each SNU. The HMI monitors the plant status and measurements in both modes. The safety signals are independent of the selected mode. Each SNU shall have a panel signaling the LCM/RCM and on/off operations, just as the interlock devices (alarm push button, safety interlocks).

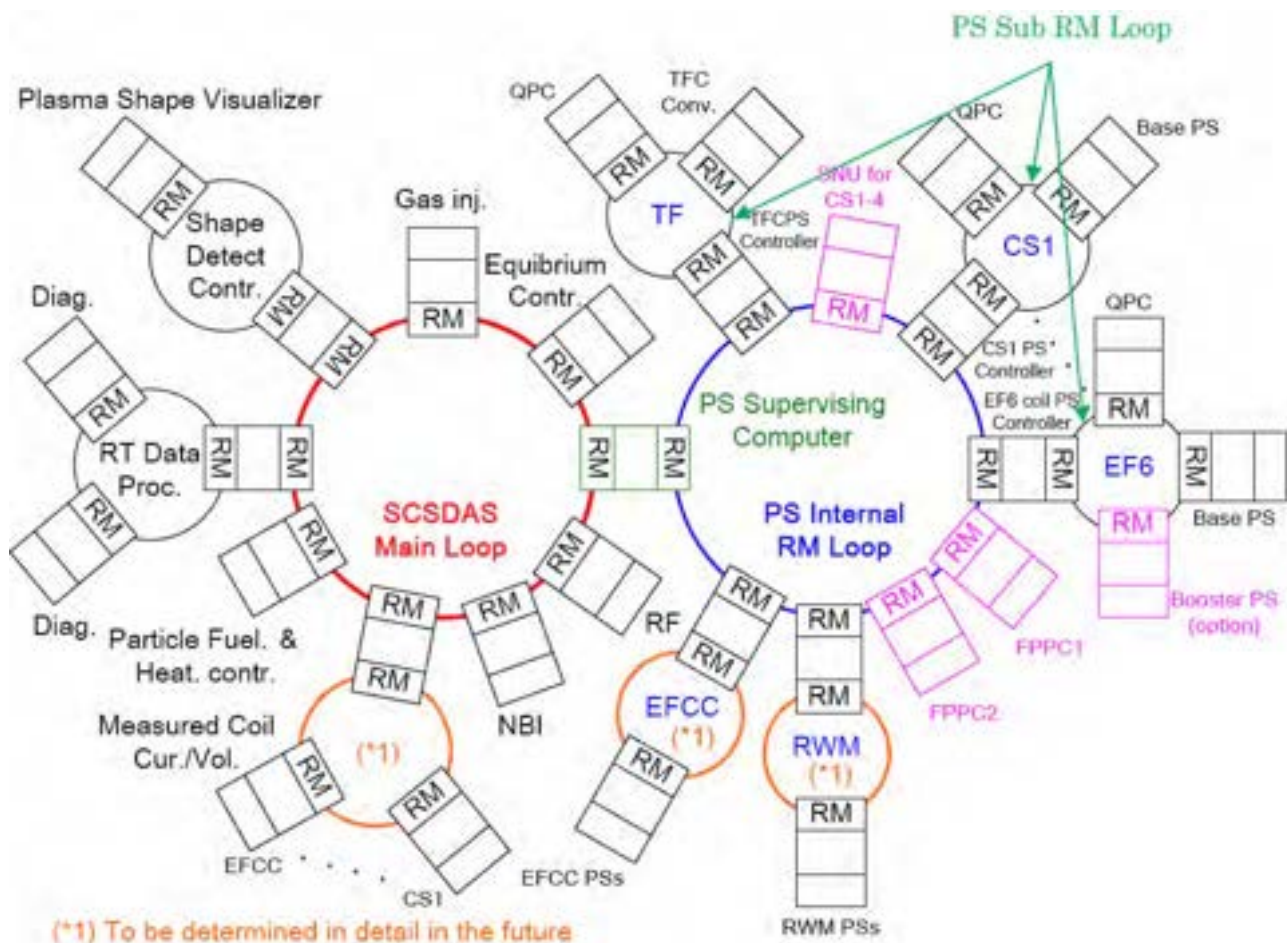

Fig. 7: RM loops for JT-60SA power supply control system [7].

In the LCM case, the HMI provides an easy management of all the input/output actions (commands, sequences, status monitoring, measurements, and so on) necessary for effective SNU commissioning, testing and troubleshooting. Also in LCM, the LCC transmits the signals from the SNU to the PS SC. When the RCM is activated, the SNU will be under the control of the PS SC. In this case, the switching commands will come directly from the PS SC and the LCC will transfer them, after checking all the necessary conditions, to the implementing device with the time constraints summarized in Table 4.

In general, the signals can be classified according to the type of connection as:

1. Signals transmitted through the Reflective Memory (RM);
2. Signals transmitted through optical links (single signals or encoded signals);
3. Hardwired protection commands;
4. Ethernet-based links for process control and trouble-shooting.

Moreover, from the point of view of their updating rate, the signals can be classified as:

1. Slow signals, intended for system configuration, monitoring (including status and alarm visualization), slow measurements and safety interlock signals (typically managed by the SIS);
2. Fast signals, intended for purposes of timing, data acquisition and real time control (typically managed by the GPS).

The IS shall provide the RM units, produced by General Electric (see [7]), for the communications (alarms, states, commands and measurements) with the control systems. The architecture of the RM loops for the power supply control system is sketched in Fig. 7 that coincides with Fig. 1 of [7]. The IS shall also provide Ethernet access to its CPUs/controllers by using only standard ways of communications and software interfaces.

**Table 5: List of signals transferred to/from LCC from/to PS SC.**

	Description	Accuracy / Values	Analog band / Sampling / Rate	Path (from/through/to)
<b>Measurements</b>	Voltage at the SNU terminals	±1%	≥3 kHz	Each SNU → LCC → PS SC
	Total current	±1%	≥2 kHz (or ≥4 kS/s)	Each SNU → LCC → PS SC
	SS current (CT in Fig. 5)	±1%	≥2 kHz (or ≥4 kS/s)	Each SNU → LCC → PS SC
	R1 current (CT in Fig. 5)	±1%	≥2 kHz (or ≥4 kS/s)	Each SNU → LCC → PS SC
	R2 current (CT in Fig. 5)	±1%	≥2 kHz (or ≥4 kS/s)	Each SNU → LCC → PS SC
	Resistor temperature	±2.5%	≥10 Hz	From each SNU resistor (6 per SNU)
	Cooling/water temperature	±2.5%	≥10 Hz	Each SNU → LCC → PS SC
	Spare	±1%	≥3 kHz	LCC
	Spare	±2.5%	≥10 Hz	LCC
<b>Status and Alarm Signals</b>	SNU LCM/RCM	On/Off	Slow	Each SNU → LCC → PS SC
	Input GS closed	On/Off	Slow	Each SNU → LCC → PS SC
	Output GS closed	On/Off	Slow	Each SNU → LCC → PS SC
	Resistor(s) pre-arrangement	Encoded	Slow	Each SNU → LCC → PS SC
	SS close/open	On/Off	Fast	Each SNU → LCC → PS SC
	MS close/open	On/Off	Fast	Each SNU → LCC → PS SC
	SNU ready	On/Off	Slow	Each SNU → LCC → PS SC
	SNU fault	On/Off	Fast	Each SNU → LCC → PS SC
	SNU fault description	Encoded	Slow	Each SNU → LCC → PS SC
	Upload log file	Encoded	Slow	LCC → PS SC
	Emergency (Stop)	On/Off	Fast	Each SNU → PS SC
	Spare	On/Off	Slow	Each SNU → LCC → PS SC
	Spare	On/Off	Fast	LCC → PS SC
<b>Commands</b>	SNU on (auxiliaries on, initial arrangement, etc.)	On/Off	Slow	PS SC → LCC → Each SNU
	SNU off	On/Off	Slow	PS SC → LCC → Each SNU
	Selector C2 close/open	On/Off	Slow	PS SC → LCC → Each SNU
	Selector C11 close/open	On/Off	Slow	PS SC → LCC → Each SNU
	Selector C12 close/open	On/Off	Slow	PS SC → LCC → Each SNU
	Selector C13 close/open	On/Off	Slow	PS SC → LCC → Each SNU
	Selector C14 close/open	On/Off	Slow	PS SC → LCC → Each SNU
	SS open	On/Off	Fast	PS SC → LCC → Each SNU
	SS close	On/Off	Fast	PS SC → LCC → Each SNU
	MS open	On/Off	Slow	PS SC → LCC → Each SNU
	MS close	On/Off	Fast	PS SC → LCC → Each SNU
	SNU local mode	On/Off	Slow	PS SC → LCC → Each SNU
	Spare	On/Off	Fast	PS SC → LCC → Each SNU
	Spare	On/Off	Slow	PS SC → LCC

The IS has to evaluate if the management of the fast signals and of the sequence need a specific hardware (e.g. FPGA), while the slow signals can be usually handled by PLCs or industrial PCs.

Table 5 reports a tentative list of the signals between each SNU, the LCC and the control systems. A more detailed list of the status, command, alarm, measurement signals to be exchanged in JT-60SA is provided in [6]. The final list with the related features shall be fixed during the DDP. In any case, the signals to be transmitted from the components of each SNU to the LCC shall comply with what reported in Table 5 with the addition of any other signal needed for an effective and safe control of the SNU itself.

The IS shall provide all the measurements (voltage, current, temperature, water/air flow, etc.) necessary to control and protect the system, including proper adjustable thresholds. The signals defined as “spare” in Table 5 will be defined in the DDP or will be available for later modifications/integrations. Each measurement is compared with, at least, a threshold, whose trip will converge on overall signals as “SNU fault” and “SNU ready”. For some measurements (e.g. temperatures), a “warning” threshold can be necessary, too.

The measurement accuracy required in Table 5 must be evaluated considering the total measuring chain from the probe to the interface with the PS SC. The percentage is referred to the measurement full scale. The analog measurement band is the signal maximum useful frequency, corresponding to the cut-off frequency at -3 dB. This specification is alternatively based on the sampling frequency as it is done in the datasheets of some transducers. The measurement performances listed in Table 5 are only a reference for global quantities: higher accuracy, bandwidth, sampling time could be necessary to verify and control the operations of the critical elements in the selected scheme.

All the alarms from/to the SNU, the LCC and the PS SC will be of fail-safe type. This means that the absence of the signal (light, voltage, current) must be considered as an alarm’s presence.

The LCC shall elaborate, display and save a log file in which all the changes in the SNUs’ conditions and states are recorded with the corresponding time.

Both in LCM and in RCM, the LCC shall be able to pre-arrange the resistor sets by the C2, C11, C12, C13, C14 selectors (see Fig. 5) according to the desired pulse characteristics.

In every condition, the LCC has to check the right working of the SNU components and systems and carry out all the procedures, of fail-safe type, to protect them. They shall be defined in the DDP according to proposals made by the IS [11].

The subject of the human safety regarding the activities on the SNUs shall be carefully analyzed by the IS. The human safety must rely on fail-safe and hardware components (mechanical interlocks, grounding connections and switches, circuit breakers, screens, etc.). During the DDP, all the information necessary to design the system in compliance with the safety rules will be given. Detailed information on the JT-60SA safety rules can be found in [8].

### *SNU cooling system*

The SNUs will be cooled by the cooling water plants of Naka Site. The inner cooling plants of the SNU are included in this Procurement. The IS should terminate the internal cooling plants with proper flanges. The connections from these flanges to the Naka Site cooling water plants are not included in the Procurement. The mechanical interfaces for such connections shall be defined during the DDP.

The SNU will be installed at the second floor of the Rectifier building. In this room, a demineralized water cooling system for aluminum components and a raw water cooling system (JT-60SA Secondary Cooling System) are available.

The available flow rate of raw water for the SNU (breakdown resistors) cooling is 6 m<sup>3</sup>/h (see Table 2 taken from 2.7-6 of the PID [2] and the water cooling diagram in Fig. 2.7-12 of the PID [2]).

If the exhaust air temperature exceeds 100 °C, the SNU heat losses (as from the breakdown resistors) cannot be directly dissipated into the installation room and must be transferred to the raw water.

If the SNU heat losses are dissipated in the room air, the IS shall provide a report analyzing the variation of the room air temperature, in order to assure that such temperature never exceeds 50 °C due to the SNU operations.

The IS shall assess if the demineralized water cooling is necessary for the SNU static switches (mainly considering the results of his fault analysis). This option shall be agreed with the Customer during the DDP.

The sizing, layout and cooling of every power component should be analyzed in order to fulfill, with adequate safety factors, its temperature limits. The IS, considering also the dump energies of Table 3 and resistors specifications of Table 4, shall design the cooling system to ensure that the temperatures of the SNU components go back to the initial values within 30 minutes.

The available measurement systems shall monitor the hottest points of the SNU, identified during the DDP and modified, if needed, after the testing phase. The temperature measures coming from the SNU should be collected and elaborated by the LCC that controls the cooling system and provides summarized information to the PS SC.

The water circulation in the SNU shall be checked by flow switches. Insulating valves shall be installed at the interface points with the Site plant and anywhere needed to facilitate the maintenance procedures. Furthermore, proper automatic air bleed valves, filters and drain valves shall be fitted up.

### *Layout and installation requirements*

The installation is not included in the present Procurement, but some related information is reported in following.

Before the start of the installation phase, JAEA will make available all the areas where the SNUs will be installed and the services described in [8] and [9].

During the assembly and installation activities, all the requirements and rules reported in [8] and [10] shall be applied and followed.

If needed, additional layout drawings of the relevant JT-60SA buildings will be provided by the Customer during the DDP. Possible revisions necessary during the development of the design will be agreed as applicable.

The design of the SNU system shall be compatible with the JT-60SA layout and with the provided information.

The SNUs shall be installed where indicated in the drawings in the following. The SNU size shall be consistent with the available dedicated area and access gates showed in the drawings. The 4 SNUs shall be installed in the Rectifier Room of the Rectifier Building. These drawings include the areas available for the SNUs (diagonal broken lines) and some possible space allocations (rectangles SS, MS, R, S1). The space allocations suggested by the rectangles SS, MS, R, S1 are only indicative.

The average load to the floor shall be less than 700 kg/m<sup>2</sup> for Rectifier Room (see Fig. 16). This value will be confirmed during the DDP. The basement geometry of the devices shall be agreed with the Customer during the DDP.

No crane is available in the areas where the SNU will be installed.

An overall description of the JT-60SA Site and buildings is reported in Section 2.22 of the PID [2].

### *Enclosures*

All the live parts of the SNU shall be housed in cubicles and cabinets to avoid the access to hazardous parts. The enclosures must comply with the Standard IEC 60529. The protection degree of the cabinets containing the switches and the resistors must be at least IP 52DH. The IP codes could be reviewed and agreed with the Customer during the DDP. Open frames can be accepted, except for the breakdown resistors, by properly enclosing with fences or equivalent structures. The IS shall justify the selection of a particular enclosure, including the use of open frames, also considering the consequences on the electromagnetic compatibility of the SNUs and related systems.

The signals terminal blocks and the command/control boards should be separated, by a protection shield, from the hazardous parts.

The SNU internal circuits shall be protected by proper main circuit breakers. Additional circuit breakers must be inserted to separate and effectively protect different subsets of equipment according to their location or functionality. Each circuit breaker shall interrupt all the AC phases and the neutral or both the DC polarities ( $\pm V_{DC}$ ).

A 200 V AC mains plug shall be fitted inside each cabinet and shall be protected by a differential circuit breaker (16 A, 300 mA). All the circuit breakers shall be in accordance with the IEC standards.

A holder for documents shall be fitted outside one of the cabinet doors.

The cubicles shall be fitted with low-consumption lamps for internal lighting, turned on by the opening of the doors.

Dimensions of any panel, box and cabinet shall contain a minimum of 20% of spare area (for panels) or volume (for boxes and cabinets). The wiring channels shall contain a minimum of 20% of spare space.

The wiring channels shall be halogen-free and flame retardant, fitted with a cover and secured by screws.

The doors shall be provided with locks. In any case, the internal parts of the SNU will be accessible only in compliance with the safety procedures.

The thickness of the steel of the cabinets will be at least 1.5 mm. The plates will be passivated and painted by epoxy polyester powder coating. The color code will be given in the DDP.

The mechanical cabinets must be connected to the ground grid of the Site. All its metallic parts (frame, doors, panels, etc) will be linked to the ground bolt. The grounding circuits should be designed for a single short-circuit withstand and consistent with the Standards IEC 60204-11 and IEC 62271-200. All the ground connections shall be easily spotted. JAEA will connect the ground terminal of the SNU system to the closest terminal of the grounding network of the building.

Adequate test points, with easy access, shall be included in the equipment to allow quick maintenance and troubleshooting. The test points will be defined during the DDP according to a proposal from the IS.

Each cubicle must be properly cooled/heated, also taking into account the site conditions, to ensure that all the internal components can properly operate and that no damage occurs to them.

The IS should provide all the documents certifying the conformity of the equipments to the IEC standards and the shielding code (EM) according to the Standard IEC 61000-5-7 of the electronic cards enclosures.

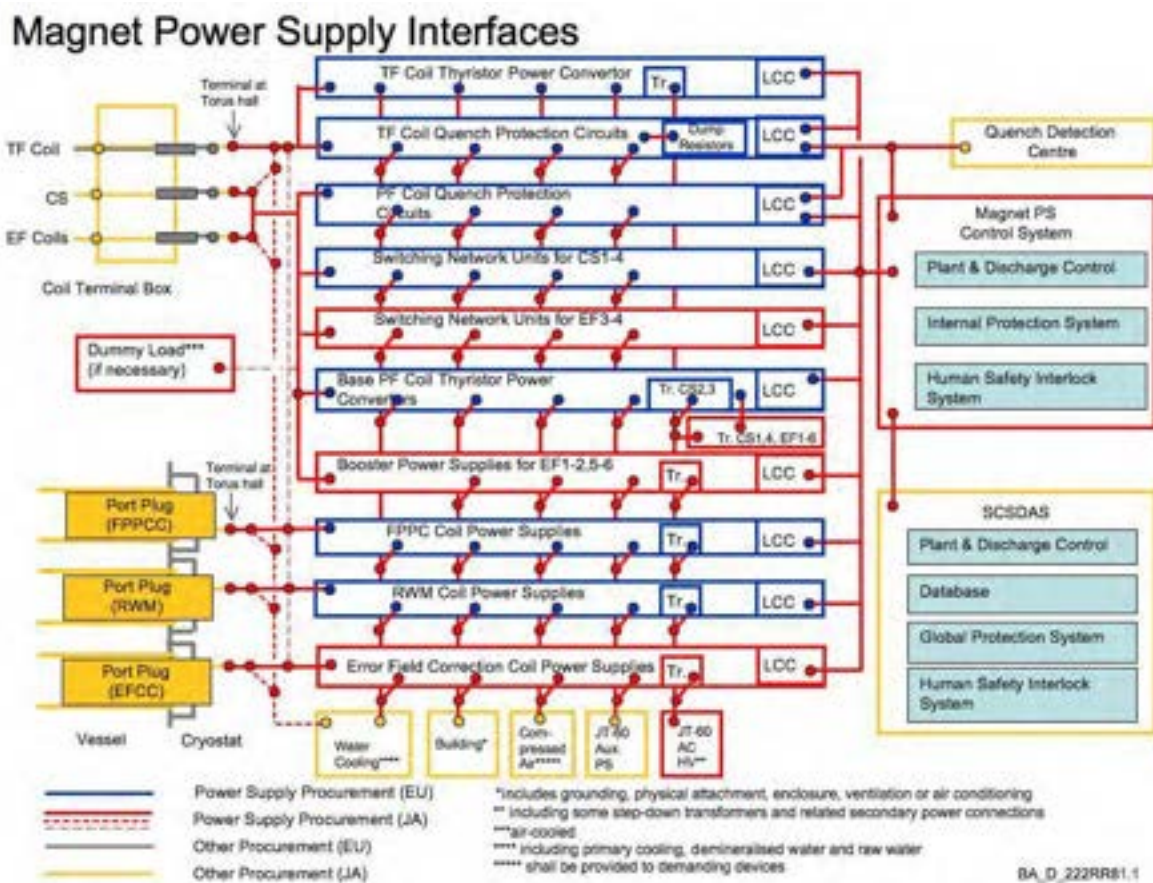

Fig. 8: Diagram of the interfaces between the PSs and the other JT-60SA systems.

### Interfaces

The JT-60SA interfaces are widely presented in the PID [2]. The IS shall particularly take care of all the information concerning the integration of the SNUs in JT-60SA (see in particular Section 4 of PID [2]).

Fig. 8, coincident with Figure 2.7-6 in the PID [2], shows the interfaces of each unit of the coil PSs with respect to the rest of JT-60SA systems. In the scheme, the interfaces are represented with circles. The colors of the interfaces indicate the respective procurement. The color of the line connecting two interfaces indicates the organization providing the physical connection between the interface points.

Fig. 9 is focused on the SNU interfaces. The external dashed rectangle stands for the boundaries between the EU (in practice, this Procurement) and the JAEA procurements. The blue dots represent the interfaces among the SNU and other systems. The final connections are part of the JAEA task. The numerical values reported in the boxes are only preliminary. The IS shall assess if these values are adequate and if additional plants/systems are needed.

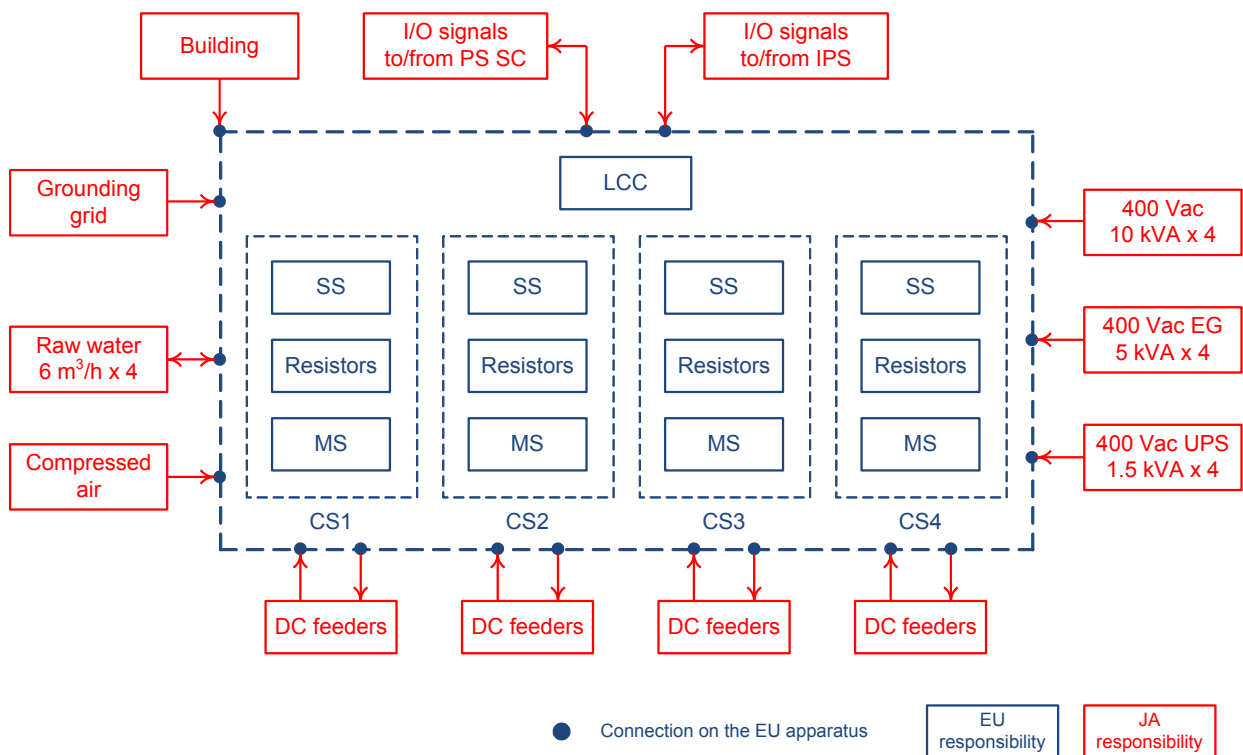

**Fig. 9: Summary of SNU interfaces and corresponding responsibilities.**

### Interface with the DC power and the coil

The two power terminals of each SNU will be mechanically connected to the corresponding converter and coil through DC bus-bar/cables not included in the present procurement. For this purpose, the IS shall provide aluminum connection terminals, including flexible links, with suitable cross-sections.

In considerations of galvanic corrosion and heat generation, the surface of the terminals, which are directly contacted with DC feeders (via flexible conductors), shall be treated by finishing and cleaning for the case of copper, or silver plating after copper plating for the case of aluminum.

The final design related to terminals and links, including final position and mechanical details, shall be agreed with the Customer during the DDP.

### Interface with the low voltage distribution system

JAEA will provide for the four CS SNUs the auxiliary electrical supplies reported in Table 6. The IS shall verify these data with respect to his requirements.

The JAEA 400 V AC normal and emergency (Emergency Generator and UPS) networks will supply the control and auxiliary plants of the SNU system.

The Emergency Generator is activated in case of failure in the normal power network. Since the generator takes few tens of seconds to start up, the power to the loads is interrupted during this time.

The IS shall design, and agree with the Customer during the DDP, the low voltage internal distribution system to be provided.

The interface between the SNU and the JAEA AC systems consists in the connections of the supply cables to the SNU terminal blocks. The IS shall install the terminal blocks of the low voltage cables in the SNU cabinets.

JAEA will provide the low voltage distribution board including the circuit breakers and the low voltage supply cables. Moreover, JAEA will lay down the low-voltage supply cables to the SNU and will terminate them at the SNU cubicles.

**Table 6: Auxiliary voltages for the four CS SNUs.**

Type	Network	Emergency Generator	UPS
Nominal voltage	400 V AC	400 V AC	400 V AC
Phases and wires	3ph 4w	3ph 4w	3ph 4w
Voltage variations	±10%	±10%	±5%
Nominal frequency	50±0.1% Hz	50±5% Hz	50±0.1% Hz
Total harmonic distortion	–	–	<5%
Maximum available power	40 kVA	20 kVA	6 kVA

### *Interfaces with the fluids systems*

An industrial standard compressed air plant is available in the installation area. If needed, the IS shall identify the features of the compressed air facilities.

The internal distribution system of the compressed air is a task of the IS. The IS shall connect his apparatus to the JAEA compressed air distribution system, adapt it to the specific needs of the apparatus (valves, measurements, filtering, lubrication, drying, pressure value, and so on) and distribute it among all devices where necessary.

Enough compressed air shall be stored in the procured apparatus to operate a full cycle (open-close-open) of all the switches. The pressure level of the stored compressed air shall be monitored and controlled, also by including suitable status/alarm signals.

JAEA provides the pipes close to the SNU cubicle and connect the local compressed air distribution system to the SNU pipes. The interface between the SNU and the JAEA compressed air distribution system consists in the termination of the pipes in the SNU cubicles.

### *Interface with the grounding grid*

Each SNU, LCC and cabinet shall have a ground bolt. JAEA will connect one of them to the nearest grounding terminal of the grid. The IS shall realize the internal grounding connections among the SNU parts with copper conductors of adequate section, able to carry the fault current without voltage rises dangerous for the human safety.

All the power ground connections for the SNU high-voltage equipment shall be sized in compliance with the IEC standards.

### *Interfaces with the building*

All the SNU components will be installed indoor, in the Rectifier Room of the Rectifier Building in Naka Site. The drawings show the areas available for all the SNU equipment. No extra areas will be available for the assembling.

Water cooling, compressed air and low voltage distribution plants are available in the installation room.

The IS shall design the SNUs taking into account the constrains on the maximum load of the Rectifier Room floor.

JAEA will provide to the IS's staff the services described in [8] and [9].

**Interfaces with PS SC, SCS DAS, GPS and SIS**

The SNU LCC will exchange slow and fast signals with the PS SC. The interfaces for such signals should be mainly based on Ethernet and RM cards.

The general architecture, the communication principles, the exchanged signals and the RM loops are described in [6] and [7].

The exact rules for the selection of the interface type shall be agreed during the DDP. In general, only the RM-based signals should be adopted for communications necessary during the experiments, while Ethernet should be used only for diagnostic purposes.

The IS shall provide the suitable terminations for the interface to the PS SC. JAEA will provide the optical fibres to connect the PS SC to the SNU LCC and will terminate them in the LCC with complementary connectors. The IS shall select the most suitable connector type on the basis of his own experience. In case of selection of not-widely available connectors, the IS shall provide also the complementary connectors.

The signals between the SNU and the IPS shall be defined with the Customer during the DDP on the basis of the IS's proposals (see also the proposal in Table 5).

**SNU reference scheme**

This section presents a reference scheme for the SNU design. Obviously, the IS is free to propose another scheme that he consider more suitable to meet the technical specifications on the basis of his own experience. The final scheme shall be agreed with the Customer during the DDP. In any case, independently from the selected scheme, the IS takes upon him the full responsibility of the procured components included in the present technical specifications.

The most relevant requirements of the SNU are the time accuracy and repeatability of the SS and MS operations. In addition, these performances should be obtained minimizing the maintenance time necessary for the re-establishment of the switch contacts.

Especially for these reasons, the proposed reference design is based on the "hybrid scheme" sketched in Fig. 10. The name of "hybrid circuit" is due to the fact that the SS is implemented by two systems in parallel: the former is based on a electromechanical by-pass switch (BPS), the latter on a static circuit breaker (SCB), implemented by Integrated Gate-Commutated Thyristors (IGCTs). The SCB must meet the requested switch-on/off times supporting the BPS in diverting the current to the resistance R1.

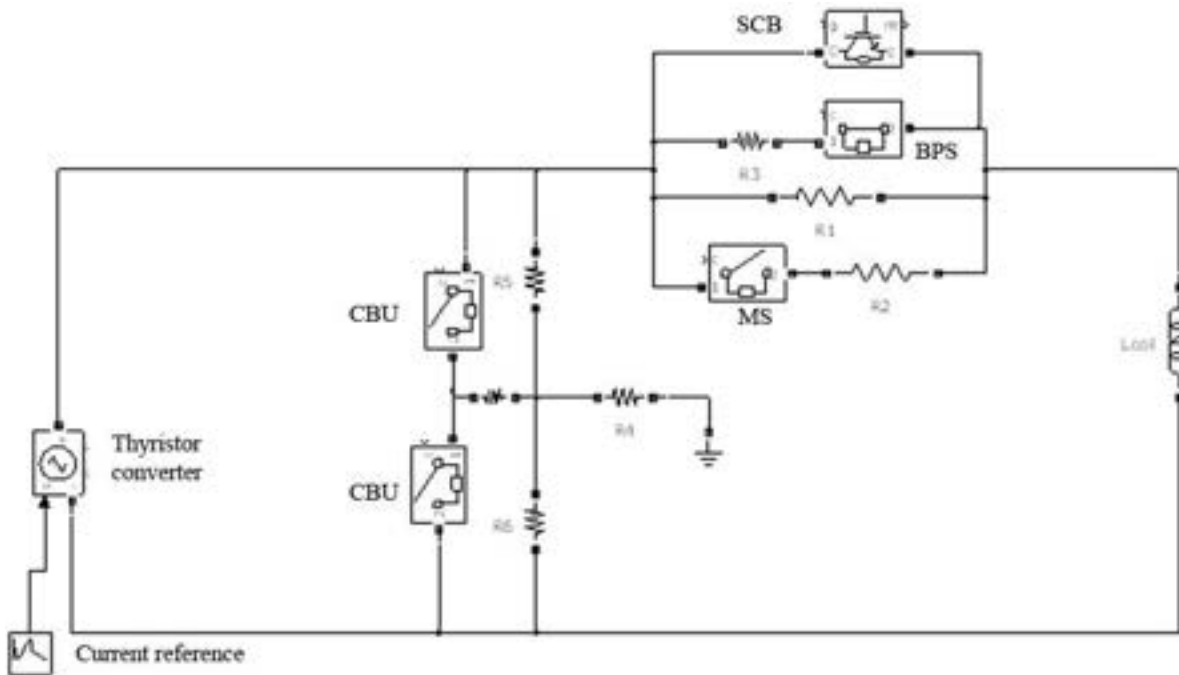
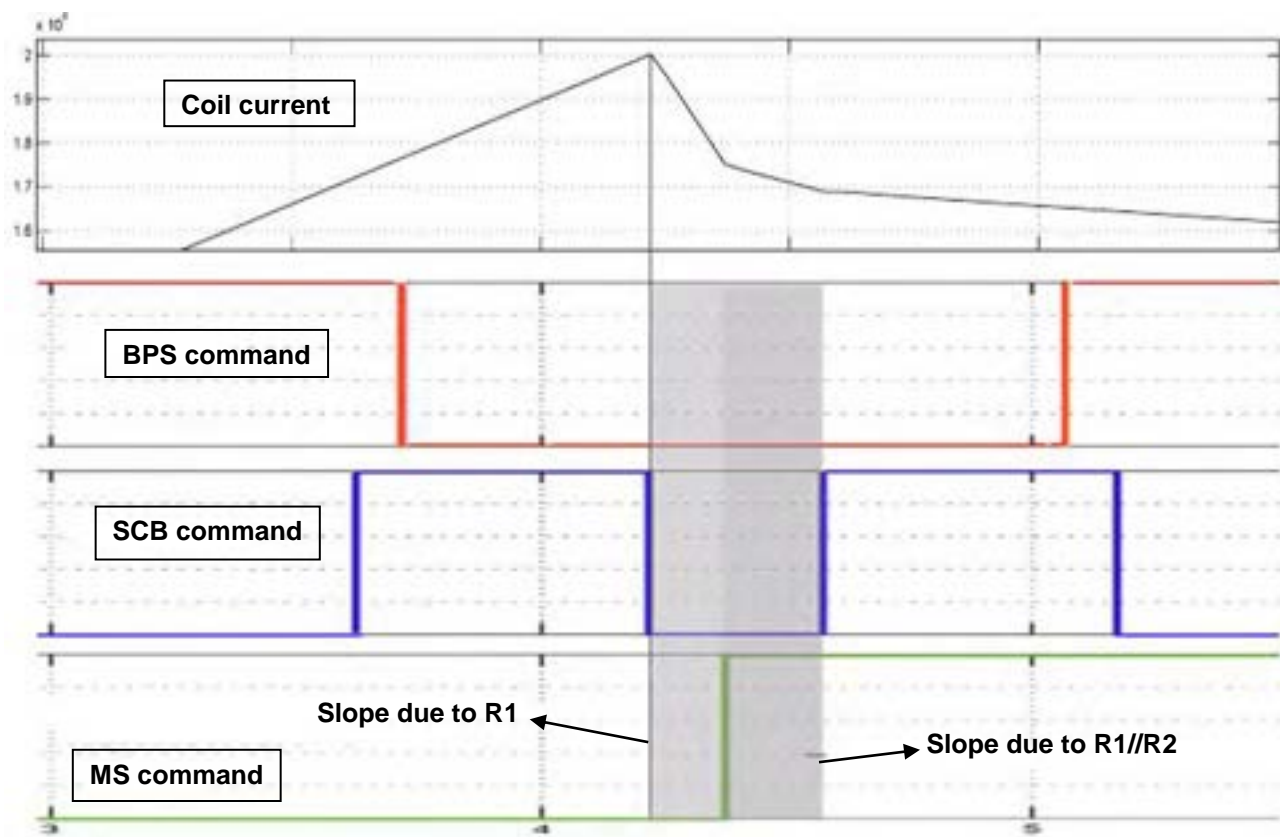

Fig. 10: Proposed hybrid scheme (captured from a simulation model).



**Fig. 11: Example of switching operations in the hybrid scheme. At the breakdown, the current abruptly decreases with two different slopes due to the SNU resistors R1 and R2.**

This design based on the hybrid scheme has been investigated in several simulations. In particular, Fig. 10 shows a simulation model including the thyristor converter voltage source, the current reference signal, the crow-bar unit (CBU), the voltage divider (obtained by the resistors R5 and R6) with the ground connection (R4) and the coil load (Lcoil).

The resistance R3 in Fig. 10 is connected in series with the BPS to create the minimum voltage drop that ensures a full conduction in the SCB, thus reducing the opening current in the BPS. Since, of course, this resistor introduces also heat dissipation, its utility and optimal value must be evaluated by the IS.

#### *Typical operation sequence of the reference scheme*

The basic principles of the proposed SNU scheme are here described with the help of Fig. 11. The time and current values in the graphs are only examples for preliminary simulations and not necessarily consistent with a real case. The first row in Fig. 11 reports the coil current, practically coincident with its reference signal (current scenario). The other three sub-figures of Fig. 11 display the sequence of opening/closing actions of the three switches (when the signal is high the switch is closed and vice versa).

The operation sequence is summarized in the following:

1. Before the breakdown (magnetization phase) the current in the coil increases up to its nominal maximum (20 kA). In this phase, the BPS is closed, the SCB and the MS are opened.
2. Shortly before (hundreds of milliseconds) the breakdown, the SCB switch is closed, the current diverts from the BPS to the SCB.
3. The BPS and, successively, the SCB are opened, pushing the current in the resistor R1.
4. The MS inserts the second resistance R2. This terminates the breakdown phase.
5. The cycle goes on returning to the initial conditions: the SCB and, successively, the BPS are closed, diverting the current from the resistors

6. At the end of the SNU operations, the SCB is opened and only the BPS is connected in the circuit. It is interesting to stress that in this circuit topology the current in the MS is very low and it can be easily opened.
7. After the SNU operations, the current is controlled only by the thyristor-based converter
8. If the coil current changes direction, the negative current flows only in the BPS. Anyway, the coil current can be inverted by the CRL (see Fig. 2).

As stated in Table 5, the fast open/close commands for the switches are sent from the SCSDAS and form the PS SC to the LCC. The LCC must adapt and transform them to the commands necessary for the BPS, SCB and MS.

### *By-pass switch (BPS)*

The BPS as proposed in the hybrid scheme is an electromechanical device that conducts the coil current before and after the breakdown phase. Therefore, the BPS shall be designed to sustain the nominal current for the whole pulse length.

The main parameters concerning the BPS are summarized in Table 7 (see also Table 4 in which only the SS is considered). The IS design shall include a description of the main characteristics of the selected device in order to verify their agreement with the technical specifications.

The value of maximum current  $I_{BPSmax}$  reported in Table 7 takes into account that the plasma disruption can induce in the coil circuit a current step increase. Fig. 12 shows the induced current waveform exceeding the rated current in case of plasma disruption. The event exemplified in the figure affects a current in positive polarity, but the behavior can be simply extended to the case of negative polarity.

The maximum interrupting capability requested to the BPS depends on the selected operational scheme and could be reduced by the insertion of the resistance R3 in Fig. 10.

If the BPS is implemented by more parallel contacts, the current among them must be as uniform as possible. To this aim, the current unbalance factor for a parallel contact is defined as

$$\Delta I_{\text{contact}} = 100 \left| \frac{I_{\text{contact}} - I_{\text{average}}}{I_{\text{average}}} \right|, \quad I_{\text{average}} = \frac{I_{BPSmax}}{N_{\text{contact}}}, \quad (1)$$

in which  $I_{\text{contact}}$  is the current value in the considered contact when the total current in all the  $N_{\text{contact}}$  parallel contacts is at the maximum value  $I_{BPSmax}$ . Then, the maximum  $\Delta I_{\text{contact}}$  allowed in the contacts should be under the 20%. Such value will be verified in Factory Tests.

The opening time can be defined as the time necessary for the extinction of the current flowing in the BPS during a SNU operation equivalent to an opening of the SS (this current can be measured in the BPS branch after the BPS starts to open). In presence of arc, the opening time can be also defined as the contact opening time from the start of the arc formation to the completely opened state to ensure the required insulating performance.

In any case, the IS shall declare in his proposal the relevant characteristics and performances of the BPS and shall indicate the sequences and the conditions in which such characteristics and performances can implement the SS operations together with the SCB. This indication shall be supported by calculations and simulations (and experimental data, if available).

The BPS component selection shall be focused on the maintenance requirements: the BPS shall ensure at least 10000 mechanical open/close operations without maintenance (excluding the sacrificial contacts). The IS shall indicate the nominal number of open/close operations at nominal current before maintenance, in particular for the sacrificial contacts. This number is expected to be not less than 300.

If the switch is operated by compressed air, it shall complete at least two open/close/open cycles when disconnected from the JAEA compressed air system.

The BPS must be inserted in a mechanical enclosure. The switch on/off buttons, normally available in this kind of equipment, will be shielded by a locked door. Moreover, it will be possible to disable them in RCM.

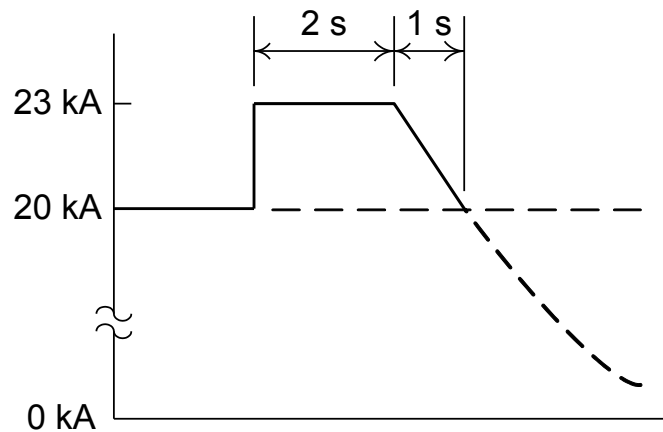

Fig. 12: Current waveform exceeding the rated current in case of plasma disruption.

Table 7: Basic technical data of the BPS (see also Table 4).

BPS Parameter	Value
Nominal current	±20 kA DC
Maximum current $I_{BPSmax}$	±23 kA DC
Maximum pulse length	250 s
Minimum repetition time	1800 s
Current direction	Bidirectional
Rated voltage between terminals	5 kV
Highest voltage for equipment (IEC 60071)	7.2 kV rms
Opening time	≤10 ms
Operation accuracy/repeatability	≤5 ms
Number of operations without maintenance (excluding sacrificial contacts)	10000
Open/close/open cycles without compressed air	≥2

Table 8: Basic technical data of the SCB (see also Table 4).

SCB Parameter	Value
Nominal current $I_{SCBn}$	20 kA DC
Interrupting capability (including safety factor)	25 kA DC
Maximum current unbalance factor $\Delta I_{branch}$	20%
Minimum repetition time	1800 s
Current direction	Unidirectional
Maximum voltage between terminals	5 kV
Highest voltage for equipment (IEC 60071)	7.2 kV rms
Switch-on/off time	≤1 ms
Operation accuracy/repeatability	≤0.5 ms
Accuracy of current measurements	1%
Minimum bandwidth of current measurements	5 kHz

### Static circuit breaker (SCB)

The specific aim of the SCB is to support the BPS in the diversion of the DC current towards the resistance R1 at the breakdown. When the SCB closes, most of the BPS current is diverted into the SCB, also thanks to the resistance in series with the BPS.

Table 8 summarizes some parameters on which the SCB design shall be based. Moreover, the IS shall consider all the other specifications included in this document.

On the basis of the technical specifications and of the information provided by the manufacturer of the static devices, the IS should select: the SCB scheme, the type of static device (e.g. IGBT) and the number of static devices and elements. The reasons for the choices shall be clearly pointed out in the technical section of the IS proposal, including both the manufacturer data and the IS valuations (scheme, calculations, simulations, etc.). The IS shall demonstrate the achievement of the required performances by the documents of the component manufacturer. The device data (type, size, numbers, etc.) can change in the final design by mutual consent between the IS and the Customer (anyway, the reasons for the modifications should be clearly pointed out).

The IS shall ensure and prove a current safety factor greater than 1.25 (on the basis of the selected component specifications), while the voltage safety factor shall be greater than 1.15, considering the value of the resistors resulting from an adiabatic heating.

The selected SCB semiconductors and related components shall sustain the maximum conduction time depending on the SNU operational sequence in both normal and fault conditions.

In case of a SCB designed by parallel branches, an equal sharing of the current in the branches should be ensured (see Table 8). This target will be quantified, similarly to formula (1), by the current unbalance factor, defined as

$$\Delta I_{\text{branch}} = 100 \left| \frac{I_{\text{branch}} - I_{\text{average}}}{I_{\text{average}}} \right|, \quad I_{\text{average}} = \frac{I_{\text{SCBn}}}{N_{\text{branch}}}. \quad (2)$$

Current measurements shall be performed in each branch to verify the level of  $\Delta I_{\text{branch}}$ .

The bandwidth specified in Table 8 refers to the current measurements performed in each SCB branch in addition to the general measurements described in Table 5 and in Fig. 5.

Independently of the values indicated in Table 8 and Table 5, the measurement accuracy, bandwidth, sampling time and time delay shall be adequate to verify and control the current in each branch of the SCB and the SNU operational times.

Analogously, in case of a SCB designed by a series of static devices parallel branches, also the sharing of the voltage in every working state (switch on/off, transients) must be considered and tested.

In case of a fault that opens a single SCB branch, the other parallel branches shall sustain the consequent current increasing for the time needed to realize an internal protection (e.g. BPS closing and SCB opening).

Snubber and clamp circuits should be inserted in the SCB unit to guarantee a proper turn-on/off process and that the component always operates in its "safe operating area".

### Breakdown resistors

The basic data for the selection of each resistor belonging to the breakdown resistances R1 and R2 are summarized in Table 3, including their values, maximum current and dumped energy. Other specifications are reported in Table 4: the accuracy on the resistor values at 20 °C shall be within  $\pm 2\%$  of the nominal values, while their increase due to the temperature shall be at maximum 10% of the nominal ones at the end of the operation shot.

The IS shall verify the compatibility between the voltage on the SNU terminals due to the resistors and the voltage limits of the SCB components.

In order to facilitate the switch commutations and to prevent any dangerous overvoltage at the SCB switching off, the resistors and all the internal connections shall present very low stray inductances (anti-inductive type/arrangement).

The temperature of each SNU resistor shall be monitored by a measurement system. The SNU heat losses cannot be dissipated into the installation room, unless the exhaust air temperature is lower than 100 °C.

Otherwise, the units shall be placed inside metallic enclosures from which the heat can be removed by the raw water plant.

### *Power connections*

The internal power connections and terminations shall be mechanically strong and thermally adequate. The impedance of the connections among the BPS, the SCB and the resistors shall be minimized in order to guarantee that the current commutations are completed in a time consistent with the requirements on the SNU switching time indicated in Table 4.

The selectors C11, C12, C13, C14 and C2 (see Fig. 5) shall be designed on the base of the specifications of the corresponding resistance. Their switching shall be commanded by the LCC through a servomechanism (pneumatic, electric). The pre-arranged opened/closed status of the selectors shall be stored in the LCC that will transmit it to the PS SC by a coded signal (see Table 5).

### *Grounding connections*

The IS shall realize the internal grounding connections between the SNU parts with copper conductors of adequate cross-sections, sized to carry the fault current without voltage rises dangerous for the human safety.

All power ground connections for SNU high-voltage equipments shall be designed according to the IEC standards. All the ground conductors shall be easily accessible. The connection between one of the SNU ground bolts and the building grounding network will be realized by JAEA.

### *Safety grounding switches*

The entire equipment shall be designed, manufactured and tested according to the IEC safety standards.

The access to the SNU high-voltage components must be possible only under the best safety conditions. Therefore, each SNU shall be equipped with two grounding switches (GSs in Fig. 5) connected to its power input and output terminals. The doors (or any other entrance) of the SNU high-voltage enclosures can be opened only after the closing of the grounding switches. Similarly, the grounding switches can be opened only after the closing of the enclosure doors.

The GS operation shall be motorized and allowed only in LCM. The GS operation shall be constrained by an interlock key system, connected with the high-voltage sources upstream and downstream the SNU. During the DDP, the Customer will give to the IS all the information and the procedures necessary to arrange the interlock system.

Limit switches will signal to the SCSDAS and SIS (through the LCC) the open/close status of the GSs (an open contact in the limit switch means that the GS is closed to ground). Besides, light indications will be placed on the SNU enclosure.

### *Design and construction*

The design and construction of the entire equipment shall comply with the best current engineering practices. The concepts of simplicity and reliability shall be essential in the design in order to ensure a long continuous service with minimum maintenance requirements. Modularity shall be used to the maximum possible extent to minimize the time required for maintenance and repair.

Systems, components and design shall be as standard as possible. It is preferred to avoid as far as possible the use of specifically designed components.

The use of ignitrons (containing mercury) is not accepted by the Customer.

All the components and cables shall be securely braced against mechanical forces occurring during shipment and against electromagnetic forces occurring during normal operations and fault events.

### *Seismic design*

The SNUs are not considered systems with safety functions in JT-60SA and then the standards for a seismic resistant design are not applicable.

### *Transmission and insulation signals*

The transmission of the signals between components placed inside high voltage areas and components/equipment placed in low voltage (accessible) areas shall be as much as possible via optical fibers, which also assure a high insulation of the signals. Alternatively, other systems for galvanic insulation

between high voltage and low voltage parts may be proposed. In any case, with the exception of the optical fibers, these systems shall be subjected to the approval of the Customer during the DDP.

A fail-safe logic shall be adopted for the elaboration and transmission of all the alarm/fault signals.

### *Cables and optical fibres*

All used cables shall be selected, sized and laid according to applicable IEC standards.

Cables and optical fibres insulation shall be LSOHFR (Low Smoke, Zero Halogen, Fire Retardant) according to the Standards IEC 60754 and IEC 60332.

Cables/bus-bars shall be de-rated for parallel connection and installation as specified in the applicable IEC standards.

All cables and optical fibres shall have appropriate mechanical support to minimise strains on the connectors and to respect manufacture requirements on bending radii.

Whenever possible, cables carrying signals from different sources shall be grouped and marked appropriately with the identification of the source. Within cubicles/panels, all cables shall be clearly identified with an approved label and this label shall be clearly visible within the cubicle/panel.

Analog signals shall be routed separately (using different cables) from digital signals. Twisted pair cables shall be used to reduce interferences to control, protection and monitoring signals.

During the DDP, the IS shall demonstrate that the proposed cabling and wiring systems comply with the applicable EMI/EMC IEC standards.

### *Use of oil and combustible materials*

Material that would support combustion or that would release hazardous fumes in the event of a fire shall not be used without prior approval of the Customer.

PVC should be avoided and may be used only for low voltage wiring inside control cubicles and only if agreed with the Customer, though it is not the preferred solution.

PCB and PCT (polychlorinated 2-phenyl and 3-phenyl) type materials shall not be used in any component. Oil filled equipment shall not be installed indoor.

### *Audible noise*

In stationary conditions, all the equipments shall operate without undue vibrations and with the lowest possible audible noise in order to avoid nuisance and any harmful effect. During the switching phase, noise and vibrations shall be reasonably minimized.

In particular, the daily average noise value outside the cubicles (i.e closed doors) in normal operating and stationary conditions must not exceed 85 dB(A).

### *Access to the equipment*

An easy access to all the equipment and components shall be ensured for maintenance and troubleshooting operations.

Windows shall be provided where internal items need to be visible. If glass is used, it shall be of shatterproof safety type.

### *Spare parts*

The IS shall provide within this Procurement a basic set of spare parts, including at least:

1. 2 complete branches of the SCB (e.g. IGCTs) including their firing systems;
2. A set of sacrificial contacts for the BPS and the MS (in case of electromechanical devices);

Moreover, during the DDP, the IS shall provide a list of recommended spares that could be ordered by JAEA to cover the equipment specified operational life, beyond the warranty period. This list shall include the individual prices and an indication of their time validity. This list could be used by Fusion for Energy to request an extension of the standard commercial warranty or a supply of spare parts. This option can be exercised, at the price proposed in the list, until the delivery of the Supply. The spare list can be changed in order to purchase fewer or more parts with no cost variations.

The preparation of the described list will not relieve the IS from his obligation to replace any part damaged during installation or testing.

### *General testing and approval requirements*

The whole of the provided equipment shall be subjected to inspections and tests to prove the compliance with the technical specifications. The following sections outline the tests to be performed and the relevant test conditions determined on the basis of the reference design. The IS shall propose a complete testing plan, including modifications and integrations, especially in relation to his design modifications, which shall be agreed with the Customer during the DDP.

Factory tests shall be performed in the IS's works, in the works of a sub-supplier or in another suitable test facility agreed between the Customer and the IS. In any case, the costs related to these tests shall be paid by the IS.

The Customer and/or F4E and/or JAEA representatives and/or the Project Leader or their delegated persons may witness all the Factory Type and Factory Routine Tests. To this aim, the Customer shall be informed about the relevant dates at least 2 weeks before their occurrence.

The IS shall prepare a document containing the procedures for the Factory Type Tests. This document shall be delivered at least 3 months before the starting of the tests. During the phase of manufacturing of the remaining units, the IS shall deliver the procedures for the Factory Routine Tests at least 3 months before the starting of the Factory Routine Tests. Both the test procedures shall be approved by the Customer. The IS shall submit a Site Commissioning Program. Within 45 days after the successful conclusion of each test, a report shall be prepared by the IS and submitted to the Customer for approval. This report shall include all the test conditions used testing procedures and all the records, certificates and performance curves resulting from the tests. These test records, certificates and performance curves shall be provided for all the tests, whether or not they have been witnessed by the Customer. Before any equipment is packed and dispatched from the IS's works, all the requested factory tests shall have been successfully carried out in the presence of a representative of the Customer, unless otherwise agreed.

Any item of equipment or component failing to comply with the requirements of these specifications in any respect or at any stage of manufacture, or test, shall be rejected by the Customer either in whole or in part as the Customer considers necessary. The IS shall provide for the revised product, at his own charge, to fulfill the failed requirements. This fulfillment shall be proved by new inspections and/or tests.

Approval of any test by the Customer does not relieve the IS from his obligation to meet the requirements of the specifications.

### *Factory Type Tests*

Factory Type Tests shall be performed on the first SNU (prototype). The production of the other units shall depend on the positive results of the Factory Type Tests.

Some items of the Factory Type Tests can be skipped by the submission of the related test reports, if a comparable product successfully passed identical or more stringent tests. The equivalence of the tests will be evaluated by the Customer.

Factory Type Tests shall be carried out in the IS's works (or in the works of his sub-suppliers) unless this is not possible. In this case, the tests shall be carried out in another suitable test facility agreed between the Customer and the IS.

After the successful conclusion of the Factory Type Tests, the IS shall substitute the stressed components at his own expenses, in order to ensure that the unit will be able to sustain the nominal life in Table 7.

### *Specific Factory Type Tests for the BPS*

The following tests regard the BPS installed in the first SNU (prototype).

#### *Test to verify the $I^2t$ capability and the unbalance of the BPS*

The BPS shall be able to carry a DC current of 20 kA for the time necessary to reach the thermal steady state condition. The  $I^2t$  capability can be tested by means of a current of 20 kA flowing not less than 2 hours with the actual duty cycle (250/1800), corresponding to at least 4 operations. During these tests the temperature of the contact staffs shall not exceed the maximum increase declared in the design report.

It will be possible to agree to perform the tests in AC, industrial frequency, with a value of root mean square (rms) current equivalent to the DC current.

The acceptance criteria of these tests will consist in a visual check and in a verification of the operational performances (current and time) of the switch in steady state condition at nominal current.

The current shall be measured in several BPS contacts to check its unbalance.

#### *Test to verify the electro-dynamic resistance of the BPS*

A sinusoidal current at 50 Hz with a peak value of 41 kA, without unidirectional component, shall be applied for at least 100 ms. This test shall be repeated 5 times. The requirements of the tests are satisfied if no damage occurs to the test object.

#### *Test to verify the opening and closing mechanisms*

The BPS opening and closing mechanisms shall be tested by means of 1000 operations of complete opening-closing. During this test replacements of mechanical/electrical parts are not allowed. Only the standard adjustment and lubrication are allowed. The opening time shall be measured during all the operations. All the measured opening times shall remain in the range declared by the IS in the DDP with respect to the nominal opening time value.

At the end of the 1000 operations, a mechanical check shall be performed: no mechanical problems as un-tight connections or worn parts shall be detected.

#### *Test to verify the pressure withstand and the tightness for gas-filled compartments*

If the BPS is provided with gas-filled compartments, the pressure withstand test and tightness test for gas-filled compartments shall be performed according to the applicable IEC standards.

#### *Tests on the prototype SNU*

The first developed SNU shall be tested by the procedures listed in the following to obtain, as soon as possible, any useful information on the device features. The prototype can be simplified to a design without the components irrelevant for the aims of the tests. These modifications shall be agreed between the IS and the Customer.

#### *Operational tests at reduced current and reduced voltage*

The goal of the tests is to verify the right working of a simplified SNU in which the SCB has only one parallel branch. This branch is tested with a current equal to  $1.25 \cdot I_{SCBn} / N_{branch}$ , where  $N_{branch}$  is the actual number of parallel branches of the SCB in the final design.

The normal running sequence shall be performed including the resistance R2 linked by the MS.

The timing of the test and the values of the resistors (to be inserted in the circuit) will be fixed in agreement between the IS and the Customer, in any case in agreement with the typical times of the SNU sequence in the reference scenarios.

The test shall be repeated 10 times respecting the repetition time reported in Table 4. The IS can propose and justify a shorter repetition time.

The SNU components (BPS, SCB, MS and resistors) shall be monitored with measurements of currents, voltages, temperatures and switching times.

The prototype will pass the test if the results will be in agreement with the technical specifications and with the final design.

In particular, the current has to be commutated from the BPS to the SCB and then to the resistors satisfying the maximum allowable delay time from the command and the accuracy among different tests reported in Table 4.

#### *Operational tests at reduced current and nominal voltage*

The tests can be the exact repetition of the previous ones, but the first resistor connected by the SCB in the coil circuit shall give a voltage drop of 5 kV. This can be achieved by substituting the resistance R1 in Table 3 with a test resistance  $R1_{test} = 4000 \cdot N_{branch} / I_{SCBn}$ , that shall be rated for the current, voltage and dump energy necessary for the test.

Alternatively, to avoid the preparation of the dedicated resistor  $R1_{test}$  the tests can be implemented by diverting to R14 its rated current (1.333 kA) using the complete SCB (with all the branches).

### *Operational tests at nominal current and nominal voltage*

In this case, a 20 kA current has to be diverted to the resistance R1 (with a 5 kV voltage drop) and afterwards by the MS to the parallel of R1 and R2 (the resistance resulting from all the resistors in parallel is approximately 0.0227  $\Omega$ ).

A standard running sequence shall be performed, including the second resistance R2 inserted by the MS. The current waveform of CS2 in the Design Scenario 1 reported in Table 1.2-2 of the PID [2] can be used as a reference. The test sequence and times shall be as similar as possible to the scenario, but they can be adapted (for example, by shortening the sequence times) to comply with the limitations of the test facility. The test shall be repeated 10 times respecting the repetition time reported in Table 4. The IS can propose and justify a shorter repetition time.

The SNU components (BPS, SCB, MS and resistors) shall be monitored with measurements of currents, voltages, temperatures and switching times.

The variations in the resistance values shall agree with the specifications in Table 4.

After each test, an inspection shall be made to detect possible mechanical deformations (on resistor units, bus bars, etc.). The requirements of the tests are satisfied if no mechanical deformations occur on the test objects.

The prototype will pass the tests if the experimental results will be in agreement with the technical specifications and with the final design.

### *Tests to verify the breakdown resistors*

The nominal energy (see Table 3) shall be adiabatically dissipated in the breakdown resistors. The tests can be performed on the minimum quantity of resistor modules based on the same design.

The time length of the tests will be such as the dump energies in the resistors reaches the values reported in Table 3. The test shall be repeated 10 times respecting the repetition time reported in Table 4. The IS can propose and justify a shorter repetition time.

The variations in the resistance values shall agree with the specifications in Table 4. An inspection shall be made after each test to detect possible mechanical deformations. The requirements of the tests are satisfied if no mechanical deformations occur on the test objects.

### *Functional tests to check the protection system*

In this test all the fault conditions shall be reproduced and detected and the actions to protect from these faults shall be generated.

### *Factory Routine Tests*

This section describes the Factory Routine Tests that the IS shall perform on components and assemblies.

Factory Routine Tests shall be performed in the IS's works, in the works of a sub-supplier for that specific component or assembly provided by the sub-supplier, or in another suitable test facility agreed between the Customer and the IS.

The Factory Routine Tests shall ensure that the supplied equipment meet the requirements of the specifications.

Factory Routine Tests shall include also all the routine electrical, mechanical and hydraulic tests, in accordance with the relevant IEC Standards and the tests listed in the specifications. Moreover, the Factory Routine Tests will include any additional test agreed between the Customer and the IS during the DDP. For the equipment not covered by any IEC standard and not specifically mentioned in these specifications, the tests shall be agreed with the Customer during the DDP.

### *Factory Routine Tests on the BPS*

All the BPSs shall be tested according to the Standard IEC 62271 where applicable. The tests in the following shall be included as a minimum.

### *Voltage to ground withstand tests (main circuit)*

The BPS in closed position shall be subject to short-duration power-frequency test (20 kV rms, 50 Hz for 1 minute, see also [5]). The requirements of the tests are satisfied if no discharges occur on the test object.

### *Voltage to ground withstand tests (auxiliary and control circuits)*

The voltage withstand tests for the auxiliary and control circuits shall be performed according to the Standard IEC 60146-1-1. The requirements of the tests are satisfied if no discharges occur on the test object.

The IS can propose an alternative reference standard or test procedure for these tests.

### *Mechanical operating tests*

At least 10 closing-opening operations shall be performed in the worst conditions specified for the device (for example, at the minimum auxiliary voltage and/or air pressure). The opening time shall be measured during each operation. All the measured opening times shall remain in the range declared by the IS in the DDP with respect to the nominal value of the opening time.

### *Design and visual check*

The design and visual check shall be performed according to the Standard IEC 62271.

### *Factory Routine Tests on the SCB and MS*

During the DDP, the IS shall define the most suitable tests for the selected SCB and MS architecture and components. Anyway, the tests listed in the following shall be included

#### *Visual and electrical check*

The visual and electrical check shall include the power and control connections. The design and visual check shall be performed according to the Standard IEC 62271.

#### *Voltage to ground withstand tests (main circuit)*

The switches shall be subject to short-duration power-frequency test (20 kV rms, 50 Hz for 1 minute, see also [5]), with the procedure pointed out in the Standard IEC 60146-1-1. The requirements of the tests are satisfied if no discharges occur on the test object.

### *Voltage to ground withstand tests (auxiliary and control circuits)*

The voltage withstand tests for the auxiliary and control circuits shall be performed according to the Standard IEC 60146-1-1. The requirements of the tests are satisfied if no discharges occur on the test object. The IS can propose an alternative reference standard or test procedure for these tests.

### *Tests on the SCB and MS operational timing*

The tests aim to measure the delay and accuracy values and to compare them to the values specified in Table 4 and Table 8. The details of these tests, including the testing currents, shall be agreed between the Customer and the IS in the DDP.

### *Tests on breakdown resistors*

The breakdown resistors shall be tested as described in the following.

#### *Measurement of the nominal resistance*

The resistance value of each resistor shall be within  $\pm 2\%$  of the nominal value when measured at 20 °C.

#### *Voltage to ground withstand tests*

The two sets of resistors shall be subject to short-duration power-frequency test (20 kV rms, 50 Hz for 1 minute, see also [5]) with the procedure defined in the Standard IEC 60146-1-1. The requirements of the tests are satisfied if no discharges occur on the test object.

### *Tests on grounding switches*

All the GSs shall be tested according to the Standard IEC 62271-102 where applicable. The tests described in the following shall be included as a minimum.

#### *Voltage to ground withstand tests (main circuit)*

The GS in closed position shall be subject to short-duration power-frequency test (20 kV rms, 50 Hz for 1 minute, see also [5]). The requirements of the tests are satisfied if no discharges occur on the test object.

### *Voltage to ground withstand tests (auxiliary and control circuits)*

The voltage withstand tests for the auxiliary and control circuits shall be performed according to the Standard IEC 60146-1-1. The requirements of the tests are satisfied if no discharges occur on the test object.

### *Mechanical operating tests*

At least 10 closing-opening operations shall be performed.

### *Design and visual check*

The design and visual check shall be performed according to the Standard IEC 62271.

### *Tests on the SNU LCC*

The routine tests described in the following shall be carried out on the LCC assembly as a minimum.

### *Insulation to ground tests*

Each circuit intended for connection to AC mains supplies or DC supplies shall withstand 2 kV rms at 50 Hz applied for 1 minute. The tests shall be followed by the measurement of the insulation resistance at 500 V DC. The requirements of the tests are satisfied if no discharges occur on the test object.

### *Functional tests*

Each element shall be fully tested to verify its compliance with the functional requirements of these specifications and achievement in the operations for which it was designed.

The safe and correct operation of all the protective circuits and the overall coordination of the protections shall be checked.

### *Tests on current and voltage transducers*

It is generally assumed that transducers are certified by their manufacturer. If not, each transducer shall be tested by the IS to demonstrate its compliance with the required performance specifications. The details of these tests shall be agreed between the IS and the Customer.

These tests can be skipped by the submission of the related test reports prepared by their manufacturers.

### *Tests on electrical and optical fiber cables*

Electrical and optical fiber cables shall be tested in accordance with the applicable IEC standards, in particular with the Standard IEC 60502 and with the Standard IEC 60332.

### *Tests on water cooling and compressed air systems*

The SNU water cooling circuit shall be tested at 850 kPa for 6 hours without any leakage.

If the SNU design includes a compressed air distribution system, such system shall be tested at 2.4 MPa for 6 hours.

### *EMC/Immunity compliance*

Compliance shall be tested of the whole control equipment supplied under the Contract with the applicable immunity requirements of the Standard IEC 61000-6-2 (level 3) or IEC 61800-3 (second environment cat. 4). The EMC compliance shall take into account: the emission, the immunity, the DC field perturbation and its effects, the EMC requirements in term of grounding, earthing, screening, and so on.

Whole equipment including internal wiring shall be designed and tested in compliance with the electromagnetic perturbation in site and considering the environment.

### *Site Acceptance Tests*

The tests described in this section are not included in the present Procurement. Nevertheless, these tests are summarized in the following for IS convenience as they are scheduled after the SNU installation in the JT-60SA site.

During the testing activities, all the requirements and rules reported in [8] and [10] shall be applied and followed.

### *Tests to verify the voltage to ground insulation*

For the test a voltage of 5 kV rms at 50 Hz shall be applied for 10 minutes (see also [5]). The requirements of the tests are satisfied if no discharges occur on the test object.

### *Functional tests on the control, protection and measurement systems*

These functional tests shall verify the control system, the protection system and the results of the measurements performed by the systems. Each component shall be fully tested to check its correct working. The safe and correct operation of all protective circuits and the overall coordination of the protections shall be checked.

### *Functional tests on the connections to the auxiliary systems*

These functional tests shall verify the correct connection to the auxiliary systems (power supply, compressed air, etc.). All the components shall be fully tested to check its correct working. The safe and correct operation of all the protective circuits and the overall coordination of the protections shall be checked.

### *Tests to check the connection of the breakdown resistors*

These additional tests will be done only if the necessary test circuits, with a suitable power supply and dummy load provided by JAEA, will be available at the time of the Site Acceptance Tests. These tests shall check the connection of the breakdown resistors in the power circuit. The details of the test arrangement shall be agreed with JAEA. The maximum level of currents and voltages will be the nominal one or lower, depending on the ratings of the available power supply and dummy load. A DC current ( $\leq 20$  kA) shall be applied to the circuit having the dummy load and the SNU connected in series. The typical operating sequence shall be performed, with the complete current diversion to the resistors and vice versa.

### *Packing and transport requirements*

The IS shall be responsible for the transport, including packaging, handling and storage during the transport, of his contributions to the PoE in Japan [3]. JAEA shall be responsible for transport, including handling and storage, during the transport from the PoE to the Naka Site.

The IS shall issue, at least 10 months before transportation to Japan, the "Specifications for Handling and Transportation" of all the procured components. These specifications shall include, at least, the dimension and weight of each transported package and the detailed instructions to properly handle and transport each package.

In any case, the IS shall maintain, with respect to the Customer, the full responsibility of the procurement. For this scope, the IS shall include in each package any stress sensor and provision to effectively monitor and verify that the package itself and anything included is substantially sound.

### *Packaging*

The sub-components forming the overall supply of the SNUs and their parts shall be packaged respecting the limits indicated in [3].

It is assumed that standard limits will be respected. If any deviation is foreseen, this shall be agreed with the customer and JAEA at least 18 months before the transport to Japan.

The packaging must provide adequate mechanical and environmental resistance to road and transoceanic ship transport. The packaging must provide adequate attachments for loading and unloading by crane or equivalent lifting/moving tools and for its stable fixation on trucks and ships.

Packaging materials shall be in agreement with Japanese rules and with international sanitary rules (i.e. the use of wood requires the corresponding phyto-sanitary certificate...). Packaging shall be made and managed in order to avoid and prevent contact of the components with any contaminant agent.

The packaging must ensure clear identification of the transported components.

### *Inspection of the packaging prior to the shipment*

The packaging of the ready-for-shipment components shall be inspected at the manufacturer premises to verify the respect of the requirements for transport. The inspection shall consist in a visual verification of the packaging and in a review of the formal and technical documentation for transport.

The inspection and documentation verification shall be performed at the presence of representatives of the IS, of the Customer and of both the IAs. An official note of the inspection shall be prepared and approved by the present representatives.

### *Handling and storage*

The handling shall be performed according to procedures minimizing the risks of damage to the components.

The storage shall prevent any possible contact with any contaminant agent.

### *Delivery state*

The components forming the contribution to the JT-60SA system shall be delivered in numbered and identified packages.

### *Transports*

Road and ship transports have to be performed using the most appropriate carriers in order to guarantee component safety and delivery on time.

The IS shall provide all the documentation requested by the Local Authorities to deliver the components in Japan.

### *Check of the packaging appearance at the PoE*

At the arrival of the ship in the PoE [3], the packaging containing the components ready for unloading shall be checked after the ship unloading (DEQ, referring to INCOTERMS 2000).

The check shall consist in:

1. Visual verification of the packaging;
2. Check of shock recorder and/or acceleration sensor prepared to monitor shock and vibration during the transport;
3. Check of all the requested administrative documentation.

The check, the monitoring record and documentation verification shall be performed at the presence of representatives of the IS, of the Customer and of both IAs. An official note of the check shall be prepared and approved by the representatives.

### *Identification and traceability requirements*

The IS shall identify all the components by a metallic or plastic plate attached to the component, in which the identification code (IDC) is written.

This IDC shall correspond to the name of the component that will be indicated by the Customer during the DDP. The same name shall be used in the technical documentation.

During the DDP, the IS shall propose a list of the components needing traceability. This list will be discussed and approved by Customer. The list shall include all the components/sub-systems whose failure could imply an out-of-service of the SNU.

The IDC plate attached to a component belonging to this list shall also contain the serial number. The serial number shall allow the identification of the record containing information about the traceability of the component.

For the more standard components, not included in this list, the IS shall indicate however the necessary information for their easy procurement.

Records of the traceability of each component shall be stored and kept by the IS for at least 10 years (or the regulatory period of time, if longer). The records shall contain all the information to recognize the production process, utilized material, manufacturer, etc.

### *Documentation to be supplied*

The final documentation shall include all the documentation described in the following, corresponding to the as built configuration of the component and including all the revisions performed during the installation and the tests.

The documentation shall be provided in standard formats (Microsoft Word, Excel, PDF, AutoCAD) and shall be delivered both in electronic and in hard-copy versions (3 hard-copies and 5 CDs/DVDs are requested).

### *Industrial Supplier Quality Plan*

The IS Quality Plan may be either a single document that covers the whole scope of the Contract, including work performed by Subcontractors or an assembly of separate and well-identified documents.

The contents of the IS Quality Plan shall be in agreement with the guidelines defined in [4].

### *Progress reports*

Progress reports shall be prepared and sent monthly to the Customer, reporting in particular on:

- Main scheduled work packages and milestones;
- Main results, achievements and issues encountered in the last month;
- Main scheduled work packages and milestones for the coming month;
- Issues and actions from the last month or previous months.

### *Technical documentation*

The following documents shall be provided as a minimum during the execution of the Procurement.

### *First Design Report*

The First Design Report shall demonstrate the full compliance with the technical specifications. It may be either a single document covering the whole scope of the Contract or an assembly of separate and well-identified documents covering all the technical aspects related to this Procurement.

The contents of the First Design Report shall include at least:

- Detailed design description of the power section and the selection of rating and type of the major components, including voltage and current transducers, passive components and cables, their main data and/or data sheets (for standard components) and relevant tolerances.
- Layout drawings shall be provided showing the location of the various cubicles of each SNU, the position of the components inside each cubicle, including the voltage and current transducers. The layout shall comprise dimensions, weights and a description of the enclosures.
- Detailed design description of the control system, with block diagrams showing the main functional blocks and the flow of the various signals, the data of the main components used in the control, the list of the signals exchanged with the PS SC and the JT-60SA SCSDAS.
- Analyses of the SNU operation in normal conditions, including the calculations and studies on the integration of the various components. In particular, the calculations used to estimate the transient voltages and currents during current commutations, the maximum temperature reached by all temperature-critical devices shall be provided. For the SCB, the conduction and commutation losses shall be calculated and the junction temperature shall be evaluated using a reliable model including the characteristics of the cooling system and heat sinks. In case of parallel and series devices, a full report shall be given on the studies and tests performed to ensure correct current and voltage sharing in all the operative conditions.
- Analyses of the SNU operation in anomalous condition. The IS shall provide a table of fault conditions, which lists the fault events, their detection, the related protection (main and back-up), the related alarms and monitoring. An analysis of the stresses on the components shall be given for every severe fault and shall include all the related calculations and simulations. The effectiveness of the protective actions shall be demonstrated. Faults involving the danger of fire or explosion shall be clearly identified and described.
- The explosion  $I^2t$  for all semiconductor devices shall be identified and actions to prevent damages arising from semiconductor explosion shall be defined.
- A preliminary list of tests to be performed at factory, including individual tests on the components, Factory Type Tests, Factory Routine Tests and a description of the IS test facilities. The IS shall indicate which tests cannot be performed at his premises and shall propose alternative arrangements for their execution.
- Preliminary information regarding the site installation requirements.
- Preliminary information regarding the maintenance requirements and procedures.
- A list of reference standards used for the design of the system shall be given.

### *Factory test plan and procedures*

The IS shall complete and update the list of factory tests included in the First Design Report. The IS shall provide a detail description of the test procedures to be performed, the acceptance criteria and the time schedule for each test. The overall test schedule shall include, if any, tests that are performed outside the IS premises.

### *Site Installation Plan*

A detailed procedure of on-site assembly, installation and commissioning activities with related detailed time schedule shall be provided by the IS. The final version shall be approved by the Customer prior to shipping of the equipment.

### *Site Commissioning Program*

The IS shall provide a Site Commissioning Program detailing the test procedures to be performed, the acceptance criteria and the time schedule. The program shall be approved by the Customer prior to start the tests.

### *Test reports*

The IS shall provide written records of all the performed tests. The test reports shall be provided within 45 days after the relevant tests have been performed. The test reports shall clearly report the results of the tests, which shall be compared with the requirements given in the technical specifications.

### *Operation and Maintenance Manual*

The IS shall provide an Operation and Maintenance Manual including, but not limited to:

- Operation procedures;
- Maintenance instructions, including calibration and adjustment procedures.

The final version of the Manual shall be provided no later than 1 month after the delivery of the SNU's.

### *Specifications for non-standard components*

For non-standard components, beyond the traceability information, the technical specifications prepared for their procurement shall be provided.

### *Block and functional schemes of the control system*

Comprehensive information shall be provided for each electronic card included in the supply, sufficient to understand the card operation and to perform the necessary measurements. Expected levels and/or waveforms at the various test points shall be included.

### *Final Design Report*

The IS shall issue a Final Design Report at completion of the Procurement, reviewing all the information requested in the First Design Report and updating as necessary all relevant sections.

### *Drawings*

One set of reproducible drawings of the equipment shall be supplied. A complete cable and connection scheme shall be included.

### *Source code*

The source code of any software used for PLCs, microprocessors, PLDs or other programmable devices shall be provided, no later than 6 weeks after the system acceptance, together with sufficient documentation and software tools to modify the operation of the programmable device.

### *Import documents*

The IS shall provide all the documentation necessary to import the components in Japan and to obtain any required local clearance.

### *Training*

The IS shall provide training for the JT-60SA operating staff, in the operation, maintenance and troubleshooting of the supply.

Training shall be in the following forms:

- Preparation of an "Operation and Maintenance Manual" written in such a way that on-site technical staff may get a good understanding of the equipment, of its mode of operation and of the procedures to carry out setting and checks of protections, controls loops, maintenance interventions, etc.
- Informal instruction during the execution of the Contract, especially during tests. When Representatives of the Customer/F4E/JAEA are present they shall be allowed to ask a reasonable number of questions and/or seek clarifications without unduly delaying the IS activities.
- A formal presentation (in English) to the JT-60SA technical staff lasting up to two days. The IS shall give the presentation, unless differently agreed with the Customer, within the end of the Contract activities.
- Instruction on the use of programmers and source code for any programmable device.
- Availability to provide additional training, at JAEA expenses, if requested within 1 year from the acceptance of the system.

**Ambient conditions**

The equipment shall be installed in Naka, Ibaraki, Japan, at the JAEA Site, in the buildings described in this document. The magnetic field in these areas, due to the JT-60SA operation, will be less than 5 mT. The environmental conditions of the site are summarized in Table 9 (see also Table 2.7-13 of the PID [2]). Some information about seismic events in Naka Site are given in Section 1.8.3 of the PID [2]. They are summarized in Table 10. The floor acceleration is calculated as the product of the ground acceleration, of the superelevation factor and of the direction factor.

**Table 9: Site conditions data.**

Environmental condition	Value	Source
Elevation (above sea level)	30 m	Japan Geographical Survey Institute Database
Outdoor temperature	-13 to 37 °C	Design Report in JT-60
Indoor temperature	5 to 40 °C	–
Average outdoor temperature over 24 hours	2.4 to 25.3 °C	Japan Meteorological Agency Database
Maximum dew point temperature inside Rectifier building	28 °C	–
Wind speed (m/s)	≤40 m/s	Design Report in JT-60
Outdoor/Indoor monthly average relative humidity	≤87%	Design Report in JT-60
Pollution level	Level 2	–

**Table 10: Parameters of seismic events in Naka Site.**

Direction	Horizontal (x, y)	Vertical (z)
Ground acceleration	3 m/s <sup>2</sup>	3 m/s <sup>2</sup>
Superelevation factor	1.5	1.5
Direction factor	1	0.5
Floor acceleration	4.5 m/s <sup>2</sup> = 0.45 g	2.25 m/s <sup>2</sup> = 0.225 g

**Table 11: Parameters (to be confirmed) of demineralized and raw water cooling systems.**

Parameter	Demineralized water	Raw water
Supply temperature during operation period	20 to 35 °C	20 to 31 °C
Return temperature	≤45 °C	≤36 °C (average) ≤45 °C (absolute)
Supply pressure range	450 ± 100 kPa	0.35 to 0.7 MPa 0.25 to 0.7 MPa (EG-powered)
Design pressure of piping	–	1.0 MPa
Available flow rate at minimum pressure (taking into account Table 2)	400 m <sup>3</sup> /h 280 m <sup>3</sup> /h (EG-powered)	121 m <sup>3</sup> /h 79 m <sup>3</sup> /h (EG-powered)
Maximum acceptable pressure drop at apparatus	0.25 MPa	0.15 MPa
pH	≈7	7.0 to 8.6
Electrical resistivity	≥1 MΩ·cm at 45°C	≥0.5 kΩ·cm

The JAEA cooling system will provide raw water and a circuit for demineralized water dedicated to aluminum components.

The main parameters of the demineralized water cooling system for aluminum components and of the raw water cooling system (JT-60SA Secondary Cooling System) are summarized in Table 11. The values in Table 11 are derived from the Tables 2.7-14 and 2.7-15 of the PID [2] in which some data are still to be confirmed. The values reported for the water supply temperature refer to the operation periods. In other periods, the minimum water temperature can be 10 °C.

JAEA will provide air ventilation for the power supply rooms. The parameters of the air ventilation system are summarized in Table 12. These data can be derived from Table 2.7-13 of the PID [2] referring to the Rectifier Room where the SNU shall be installed.

Without considering the equipment operations, the air ventilation system is designed to guarantee the maximum indoor temperature and indoor humidity indicated in Table 10-4. These values must be intended as averages in the whole room volume.

The ventilation is provided by ducts and openings whose layout in the Rectifier Room is shown in Fig. 15. JAEA will distribute in the JT-60SA buildings compressed air with a pressure of 1.5 MPa without major impurities, dry and lubricated. The other characteristics of the system for the distribution of the compressed air will be defined, also considering to the requirements of the PS equipment.

**Table 12: Data for the air ventilation system.**

Parameter	Value
Room volume	22608 m <sup>3</sup>
Ambient ventilation system	414000 m <sup>3</sup> /h
Minimum indoor temperature	5 °C
Maximum indoor temperature	40 °C
Maximum indoor monthly average relative humidity	87%

### Drawings

The following figures show the drawings useful for the system layout and installation.

ENEA can send to the IS the electronic files for these drawings upon request.

The references to the JT-60SA DMS and to the ENEA document classification are provided for future references and revisions.

Fig. 13 shows the layout of the devices in the second floor of the Rectifier Building. The figure is based on the drawing titled “JT60SA-G-000215, Layout of Devices on Power Supplies (second floor),” that can be found (also in revised version) in the JT-60SA DMS with the UID [BA D 2273HC](#), and on the ENEA drawing titled “ENE-ING-A-JT-009/L, Devices in Power Supplies Areas.”

Fig. 14 shows a zoom of the preceding layout (SNU area in the second floor of the Rectifier Building), based on the same JT-60SA and ENEA drawings.

Fig. 15 shows the cross-section of the ventilation system in the Rectifier Building. The figure is based on the drawing titled “JT60SA-G-000217-0, Cross section of Ventilation system in Rectifier Building (second floor),” that can be found (also in revised version) in the JT-60SA DMS with the UID [BA D 2272UT](#). This figure is also useful to assess the available heights (that is maximum 3 m including the DC bus-bar connections).

Fig. 16 reports also the floor load in the same area. The figure is based on the drawing titled “JT60SA-G-000287, Floor Load of JT-60 Rectifier Building (second floor),” that can be found (also in revised version) in the JT-60SA DMS with the UID [BA D 224F44](#), and on the ENEA drawing titled “ENE-ING-A-JT-0010/L, Layout of Power Supply main components. Load capability of Rectifier Building 2<sup>nd</sup> Floor.”

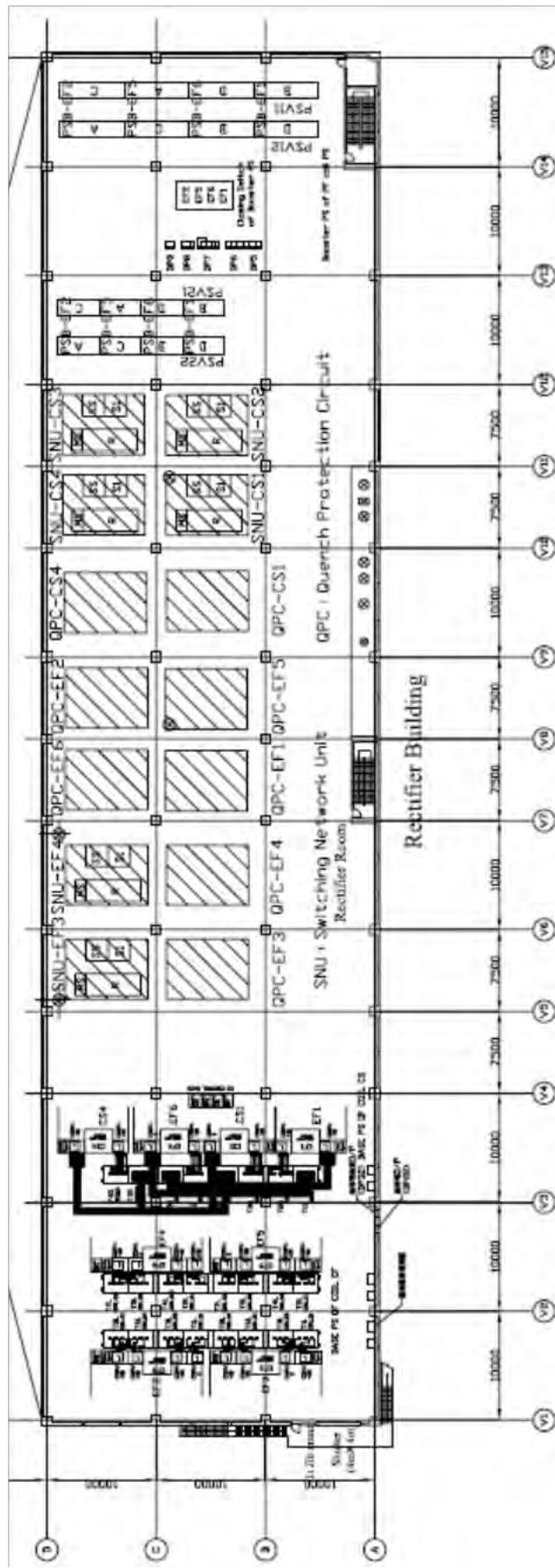

Fig. 13: Layout of the devices in the second floor of the Rectifier Building.

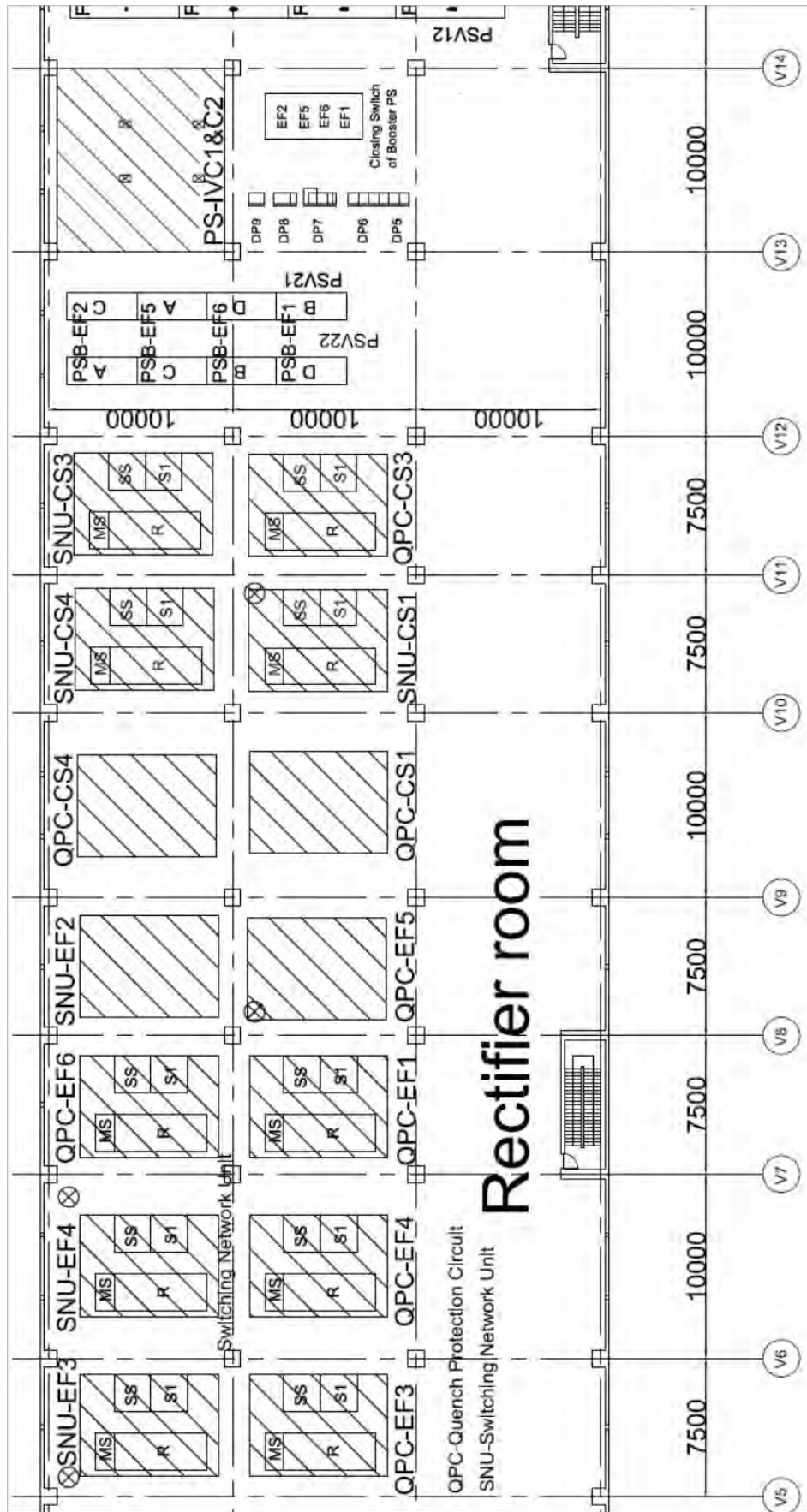

Fig. 14: Layout of the devices in the SNU area (zoom of the second floor of the Rectifier Building).

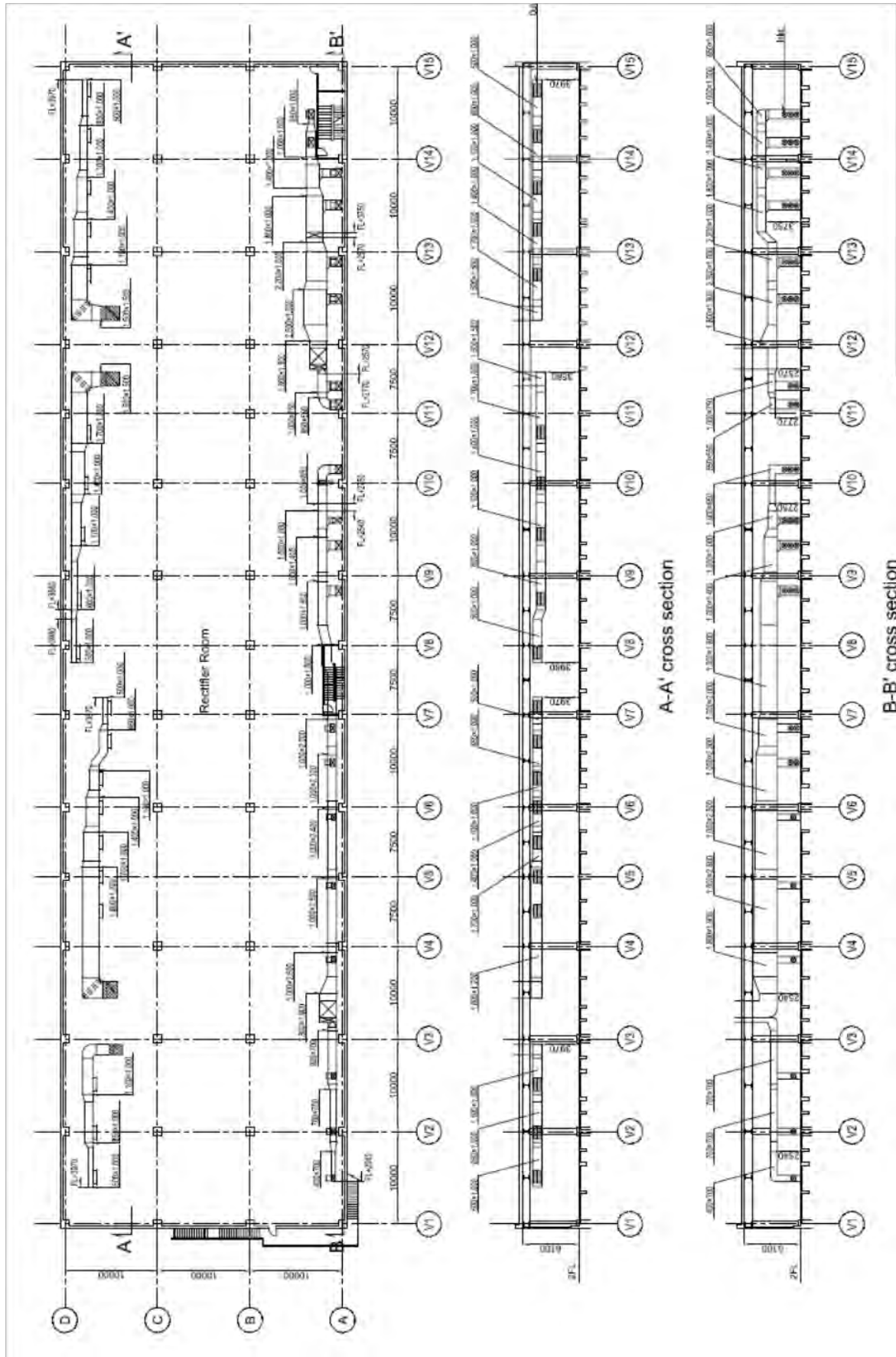

Fig. 15: Cross-section of the ventilation system in the Rectifier Building.

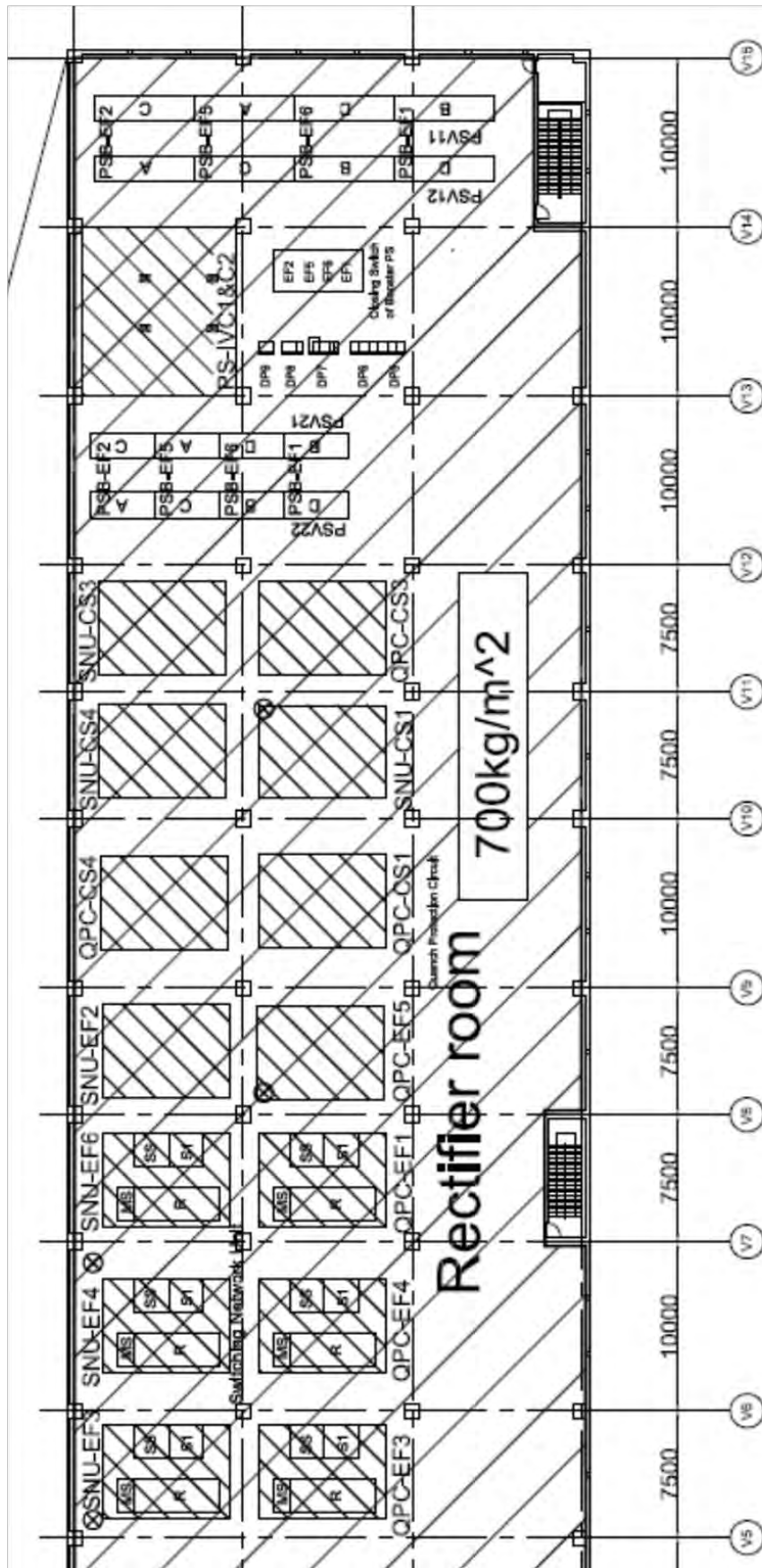

Fig. 16: Floor load in the SNU area (second floor of the Rectifier Building).

### *Management and Quality Specifications*

The JT-60U tokamak will be upgraded to a superconducting advanced (SA) tokamak and used by Europe and Japan as a “satellite” facility to ITER. The JT-60SA project is a combined project of the JA-EU Satellite Tokamak Program under the Broader Approach (BA) program.

The Management and Quality Specifications for the ENEA Industrial Supplier (MQS) are issued as Annex to the Call for Tender, managed by ENEA, for the Procurement of the 4 Switching Network Units (SNUs) of the Central Solenoids (CSs) of the JT-60SA tokamak.

ENEA will select an Industrial Supplier (IS) that will be in charge for the Procurement described in this document and in the Procurement Technical Specifications (TS). The present document is sent to all the potential ISs participant to the Call for Tender.

The present document is issued by ENEA also to comply with the Agreement Of Collaboration with Fusion for Energy (F4E). The MQS is uploaded in the JT-60SA Document Management System (DMS) where it is accessible by the people authorized by F4E and JAEA. The MQS is integrated with the information that can be found in the TS, in the JT-60SA Integrated Project Team Common Quality Management System and in the JT-60SA EU Home Team Quality Management System.

Since the MQS is related to several references, it is useful to properly define the involved subjects. The Procurement Contract will be signed between:

1. ENEA, that elsewhere is defined "Voluntary Contributor" (VC), Voluntary Contributor Designated Institution (VC-DI) or "Customer". It is important to stress that in some BA documents (issued in collaboration with F4E or JAEA), ENEA could be considered as "IS" (of the JT-60SA project).
2. IS, that elsewhere is defined "Bidder" (with reference to the Call for Tender), "Contractor" or simply "IS". Thus, the IS shall comply with the specifications described in this document both:
  - a. As a Bidder, when preparing its offer/proposal;
  - b. As the IS, during the execution of the Contract.

The MQS shall be applied also for the activities performed by the IS subcontractors/sub-suppliers. Anyway, even when it is not clearly stated, the IS can introduce subcontracts/sub-supply only in the cases allowed by the Call For Tender requirements, by the Procurement Contract and by the Italian laws.

### *Scope of the Management and Quality Specifications (MQS)*

The MQS covers the management and quality requirements that shall be implemented by the IS selected by ENEA for the Procurement and the Call for Tender general requirements. Moreover, some legal, procedural and financial requirements for the Call for Tender can be found in the Invitation Letter sent to the potential ISs and in the annexed Contract Form.

The IS shall adopt the present document as reference for the activities related to the Procurement. In particular, it shall be used as a guideline for the issue of a dedicated IS Quality Plan (ISQP). The MQS also provides a template structure for the ISQP.

The ISQP shall describe the operational quality system implemented by the IS to ensure that:

- Contract requirements will be met;
- Evidence of such compliance will be maintained.

The compliance of the ISQP with this document shall replace any need for Quality Assurance certification. Nevertheless, if the IS has a Quality Assurance certification, the related documentation shall be included as annex to the ISQP and shall be shown in any circumstance prescribed by the Call for Tender, by the Procurement Contract and by the Italian laws.

### *Contract phases, deliverables and deadlines*

Table 13 summarizes the deliverables of the Contract organized in phases.

The first phase starts at the signature of the Contract. The other phases start at the end of the preceding phase.

The subject of the activities will be clarified in the following sections. The deliverables shall include all the related documentation described in the following sections

**Table 131: List of Contract phases with main deliverables and deadlines.**

Phase ID	Phase deliverables	Duration	
1	First Design Report (DDP)	6 months	
2	Prototype (first SNU)	12 months	
3	Factory Type Tests	6 months	12 months
	SCB of the remaining 3 SNUs	6 months	
4	Completion of the remaining 3 SNUS	6 months	12 months
	Factory Routine Tests	6 months	
5	Packaging and transport to PoE	6 months	
Total duration of the Contract		48 months	

### *ENEA responsibilities*

ENEA is responsible for:

- The SNU parameters, specifications and requirements reported in the TS, ensuring that they comply with the needs of JT-60SA and with the related documentation;
- Providing and updating the information for the manufacturing and the installation, as drawings and models;
- The approval of the First Design Report;
- The approval of the subcontractors/sub-suppliers selected by the IS, when such option is allowed by the Call For Tender requirements, by the Procurement Contract and by the Italian laws;
- The review and approval of the documentation issued by the IS within the Contract;
- Monitoring the status of the Procurement through the established meetings, inspections, visits, audits, teleconferences and reports;
- Witnessing the prescribed and agreed tests;
- Informing F4E about the status of the Procurement, the dates of meetings, tests and other relevant activities for its possible attendance;
- The acceptance of the SNUs and related documentation, if they fully comply with the TS, the MQS, the Procurement Contract, the Call for Tender rules, the Italian laws and the applicable international standards.

The IS responsibilities are defined in next section.

### *ISQP requirements*

The ISQP may be either a single document covering the whole scope of the Contract or an assembly of separate and well-identified documents. The ISQP shall be written in English language.

The ISQP shall cover all the activities performed for the Procurement and is an integral part of the Contract. Any change in the content of the ISQP is subject to the ENEA approval.

The level of detail in the ISQP shall be consistent with:

- The technical requirements of the Contract;
- The complexity of the economic operators, functions and activities involved;
- The degree of design innovation;
- The involvement of innovative processes;
- The involvement of special processes which cannot be fully verified by an inspection or test;
- The degree to which functional compliance can be demonstrated by inspection or test;
- Design, performance or manufacturing margins.

The following subsections summarize the quality and management requirements to be addressed in the ISQP. The ISQP shall follow the structure of these subsections. Anyway, these items are not limitative and could be extended by the IS.

### *Objectives and deliverables of the Contract*

In this section the IS shall describe its understandings about the subject of the Contract, This description shall include the options covered in its offer/proposal. Such options may be included in the Contract if appropriate.

The deliverables are described in the TS and include the associated documentation. The IS shall issue a table including all items to be supplied, specifying:

- Deliverable number and quantity;
- Level of subcontracting;
- All the associated documents.

### *Responsibilities requirements*

The IS is responsible for the design, procurement of the components and materials, manufacture, testing and delivery of the components, in accordance with the TS and the guidelines described in the MQS.

The IS responsibility includes the following items:

- Implementation of a ISQP for the contract;
- Implementation of a IS Procurement Risk Management Plan;
- The IS shall guarantee that any activity of its subcontractors comply with the quality and management requirements written in these specifications and in the TS.

The IS shall identify the different organizations involved in Contract accomplishment and detail the breakdown of responsibilities (an organizational flowchart should facilitate the understanding).

In particular, this section shall report the name and contact details of:

1. The IS Technical Responsible Officer (ISTRO) in charge of the Contract that shall:
  - Coordinate planning, performance and control of the work, including work assigned to subcontractors;
  - keep time schedules and issue progress reports.
2. The IS Quality Representative (ISQR) for the Contract that shall:
  - be independent from the ISTRO;
  - ensure that the ISQP, quality procedures and detailed work instructions are followed during the course of the Contract in order to guarantee that all contractual quality requirements are met;
  - assess and control the quality management at the subcontractor's premises.

ENEA shall be informed of any change concerning the ISTRO or the ISQR.

### *Contract management*

The activities shall begin with an official Kick-off Meeting where the following items shall be discussed and agreed:

- Confirmation of the specifications, specific requirements and contractual input;
- Discussion and revision of the ISQP;
- Documentation review lead time;
- Plans for implementations of the Contract;
- Detailed schedule of the contractual activities, including milestones;
- Frequency of Documentation Schedule and ISCP review;
- Contents of the First Design Report and overview on the contents of the Final Report;
- Frequency and contents of the Progress Reports;
- Frequency, agenda and location of the proposed meetings (they can be held face-to-face or by teleconference/videoconference);
- Management of Intellectual Property;

The IS shall be responsible to issue the minutes of the Kick-off Meeting and of any other official meeting with ENEA.

At the end of the Contract, after the delivery of all the items, the IS shall issue a Final Report of the Contract, as detailed in the corresponding section.

### *Work Breakdown Structure (WBS)*

The IS shall provide a detailed WBS of the activities to be performed in the course of the contract. The level of details must be commensurate in order to allow a proper control of these activities, including the process qualification activities, procurement activities and manufacturing and measurement activities. This WBS must describe how potentially subcontracted activities are linked with internal activities.

As part of the WBS the IS shall issue an outline description of how they intend to manufacture the components, the means to move the components and a statement of the status of the required equipment (e.g. to be purchased, in regular use, to be modified).

### *Industrial Supplier Control Plan (ISCP)*

In this section the IS shall provide a IS Control Plan (ISCP) describing sequences of the work (including process validation, quality controls), milestones, key points, reviews and a WBS along with a corresponding detailed schedule.

The ISCP shall include at least the following items:

- Requirements originated from the design and manufacturing validation test program in the TS;
- All activities and tests to be performed in order to comply with the TS;
- List of the required hold points, production readiness review, notification points and report points.

For each particular operation, the ISCP shall:

- Identify the requirements and instructions applicable to these operations;
- Identify the operations to be witnessed and those where notification is required;
- Provide for recording the verification and completion of these operations.

The level of detail in the ISCP shall be such as:

- To prevent the inadvertent bypassing of critical operations;
- To enable adequate planning, monitoring and verification of the key activities
- To encompass the whole scope of the Contract from design to delivery including all work performed by subcontractors.

In order to ensure that operations are performed as directed in the ISCP, the document shall be directly accessible to those carrying out the work.

ENEA acceptance of the ISCP shall not relieve the IS of any contractual obligation or responsibility.

### *Time schedule management*

In this section the IS shall describe its approach to control the time schedule, including use of software or templates to monitor the time schedule. The IS shall provide the precise process to report the time schedule evolution to ENEA.

The IS shall establish a detailed time schedule of all the activities performed for the completion of the contract, including subcontracted activities. It shall present the overall strategy for design, purchasing, process/tooling qualification, manufacture and delivery of the components. This time schedule shall include the various milestones, hold points, etc.

On a monthly basis, the progress report shall include:

- The status of the actual work schedule with respect to the agreed baseline;
- The proposed corrective action to return to the baseline schedule in the event of any delay;
- The proposed mitigation for any known risk to the schedule.

### *Resource management*

In this section the IS shall provide a resource management system, detailing where applicable:

- The list of competences needed for each of the Contract stages with associated available IS resources;
- The number and type of personnel involved in each particular operation defined in the ISCP;
- Specific experience and training for personnel;
- Specific qualifications for particular operations, in particular for the standard cited in the TS.

The IS shall provide proof that all workers are properly qualified.

### *Qualification for special processes*

The IS and its subcontractors shall be responsible for the manufacturing processes qualification tests when the qualification is required. In any such case, qualification tests shall be carried out before undertaking the corresponding processes. The IS shall submit the qualification records to ENEA for approval, along with the corresponding process execution procedures.

Processes qualification shall be included in the ISCP. ENEA or its representatives will subject them to the same supervision requirements as to the rest of manufacture operations.

The provisions of this section shall also apply to the qualification of specific operators for these processes when so required by the corresponding standards.

### *Staff qualification*

Staff both from the IS and from its subcontractors participating in quality-related activities shall be appropriately qualified. Staff qualification shall be done according to applicable standards for each case.

In addition to the qualifications needed for staff in charge for tests, miscellaneous inspections and audits, the IS shall implement an internal qualification program for the staff involved in critical activities.

The IS shall issue a training plan for the staff involved in critical activities.

A file including the documentation of the staff needing qualification shall be prepared. This file does not need to be submitted to ENEA, but shall be kept by the IS or by the subcontractors for inspection and audit purposes.

Subcontracting shall not exempt the IS from its responsibility to supervise and inspect activities requiring qualified staff.

### *Material resources*

The IS shall describe the machines or process equipment that will be used in the course of the Contract.

### *Management of nonconformities and deviations*

A configuration management system shall be adopted to monitor the status of the work by the IS against the input provided by ENEA. Any divergence needs to be documented and approved by ENEA.

These divergences are addressed with the following processes:

1. Deviation: a previously proposed and approved modification to a specified requirement (current approved configuration baselines).
2. Nonconformity: any condition which does not comply with a specified requirement.

Specified requirements include:

- The technical or management specification requirements of the Contract;
- The requirements of any document issued in connection with the Contract and agreed with ENEA.

Each divergence process shall be represented in a process flowchart.

### *Management of deviations*

This section shall describe the changes management system, which includes deviation processes initiated by the IS or its potential subcontractors and those issued by ENEA or by a ENEA partner.

This system shall ensure that:

- Deviation Requests are approved by ENEA before any implementation (through a Deviation Order);
- An ENEA Deviation Notice is followed by an ENEA Deviation Order before implementation;
- Status of the configuration and all associated deviations are made available to ENEA when requested.

### *Deviation Request originating from IS or subcontractors*

When a modification to an approved configuration requirement is foreseen the IS shall discuss it with ENEA. If the proposal is considered beneficial, the IS shall request ENEA approval by issuing a Deviation Request. The deviation request shall contain or refer to all relevant material available to enable an informed decision to be taken. In particular, it shall include an assessment of the deviation consequences in terms of cost, delay and risk.

The deviation shall be implemented only after reception of a Deviation Order issued by ENEA.

### *Deviation Request originating from ENEA*

The IS shall issue an impact assessment report for each deviation notice received from ENEA. The report should contain or refer to all relevant material available to enable an informed decision on the definite course of action to be taken. It should address the consequences of the deviation in terms of technical performance, cost, delay and risk. The deviation shall be implemented only after reception of a Deviation Order issued by ENEA.

### *Management of nonconformities*

The management system shall ensure that provisions are implemented in order to:

- Detect any nonconformity and segregate the non-conforming product;
- Classify the nonconformity in two classes: major nonconformity and minor nonconformity;
- Communicate to ENEA the list of all the nonconformities and the associated actions on a regular basis (if not agreed otherwise, at least once a month);
- Ensure that the appropriate Corrective Actions are implemented to prevent repetition of nonconformity;
- Ensure that the appropriate process improvements (Preventive Actions) brought about by the Corrective Actions are implemented to prevent future nonconformities;
- Ensure that nonconformity is raised by means of a nonconformity report, in case ENEA or their appointed representatives issue a nonconformity notice after detection of a relevant discrepancy.

This classification can be assumed:

1. Major nonconformity: divergence with impact on a requirement specified in the technical specification or in the management specification.
  - The Nonconformity Report shall be sent to ENEA with proposed Remedial Actions;
  - Remedial Actions shall be implemented only after ENEA written acceptance.
2. Minor nonconformity: divergence with no impact on a requirement specified in the technical specification or in the management specification.
  - The IS can take Remedial Actions to resolve the nonconformity within its own quality system;
  - The Nonconformity Report shall be sent to ENEA for information and the Remedial Action implemented.

The IS shall indicate how, when and by whom nonconformities will be processed including those originating from its subcontractors.

### *Records management*

For the Nonconformity Report and the Deviation Request the IS shall:

- Sequentially number the Deviation Requests and Nonconformity Reports issued for each particular Contract;
- Maintain an electronic register of all Deviation Notices, Deviation Orders, Deviation Requests and Nonconformity Reports issued in respect of this Contract that must contain an indication of their distribution and acceptance status.

Nonconformity Reports, Deviation Requests, Deviation Orders and deviation consequences assessment reports are an integral part of the Contract. On or before the end of the Contract, all Nonconformity Reports, Deviation Requests, Deviation Orders, associated reports, and any relevant documentary evidence, must be included in an appendix to the Final Report.

The IS shall ensure that its subcontractors implement the same procedure to control deviations and non-conformities.

ENEA acceptance of Nonconformity Reports and Deviation Requests is limited to the particular Contract and item referred to in the Request or in the Report and does not relieve the IS of any contractual obligation or responsibility.

### *Information and documentation management*

All quality and technical official documentation and information exchange between ENEA and the IS shall be through the ENEA Technical Responsible Officer in charge of the Contract and the ISTRO.

All the documentation relevant to the Contract should be stored in an electronic document management system, if not agreed otherwise. This includes, but is not necessarily limited to:

- ISQPs and associated documents (ISCP, Documentation Schedule, and so on);
- Time Schedule;
- Risk management plan;
- Procedures;
- Quality controls records;
- Minutes of the meetings;
- Supporting analysis for Deviation Requests and Nonconformity Report;
- Progress reports;
- Records of process and design qualification;
- Engineering analysis;
- Documents associated to reviews;
- Configuration models and associated drawings.

In this section the IS shall describe its documentation management system. The documentation management system shall ensure that all the data received by the IS is properly recorded and managed and that only sound data will be provided to ENEA. The IS shall provide a Documentation Schedule, detailing all documents and records relevant to the implementation of the Contract, including work performed by subcontractors. The Documentation Schedule shall list the foreseen documents that will be loaded in the document management system. The Documentation Schedule shall be updated when necessary.

Work shall not start until the relevant Documentation Schedule has been accepted by ENEA. During the contract phase the Documentation Schedule will be the reference for the document management within the contract.

The IS shall keep all necessary documents and technical information related to the Contract for monitoring, quality assurance controls, checks and audits. If required by ENEA for its convenience, the IS shall provide copies of such documents.

The IS shall keep the documents for 10 years (or the regulatory period of time, whichever is longer) after the payment of the final balance of the Contract price or, if requested by ENEA, the IS shall transfer the requested documents to ENEA upon termination of the Contract.

ENEA acceptance of Documentation Schedule or approval of technical documents such as drawings sketches, specifications shall not relieve the IS of its responsibility of proper execution of the Contract.

### *Drawing control*

For deliverables including CAD data, the IS shall implement a drawing control system for any drawing activities. The preparation, review, and approval of drawings are accomplished through controlled procedures that establish the approval authorities and responsibilities.

A design change, to modify an approved configuration baseline, is a “change” and shall be controlled according to the above Management of nonconformities and deviations. Alteration to drawings, without addressing configuration requirements, are defined as “Drawing Modifications” (namely modifications inherent to the different stages of the drawing process, e.g. “as defined”, “as detailed” and “as built” stages).

### *Subcontracting management*

The IS shall issue a detailed procedure explaining how the requirements of the subcontracted items are defined and controlled. The procedure shall also describe how the requirements will be included in the contracting documents. The IS shall implement an Acceptance Procedure to ensure that the purchased goods and services are compliant with the contractual requirements. For each receipt of goods either delivered by ENEA or purchased by the IS, the latter shall issue a receipt note recording the unique reference of the components or a reference of the batch with the date of delivery and agreement by the IS

quality representative that the delivered goods is compliant with the requirements (including documents to be delivered).

The IS shall ensure that each of its subcontractors have a quality system compliant to the MQS and an assessment report shall be issued for each subcontractor.

Failing this, the IS shall undertake all the necessary actions to establish and maintain the quality in the subcontractor's premises in conformity with the present document and the TS.

The IS shall provide a Subcontracting Schedule, detailing:

- All major or critical items and activities subcontracted by the IS;
- Item/Activity associated specification;
- Relevant subcontractor identification (including contact person);
- Proof of subcontractor qualification (e.g. ISO 9000 certification, assessment report);
- ENEA approval of the proposed Subcontractors.

Subcontracting shall not start until the relevant Subcontracting Schedule has been accepted by ENEA.

The Subcontracting Schedule shall be updated as necessary, and the updated schedule shall be subjected to the same acceptance procedure as the original Subcontracting Schedule.

Purchased or subcontracted items or services shall be supplied together with their certificate of conformity to the specified requirements.

ENEA acceptance of the Subcontracting Schedule shall not relieve the IS of any contractual obligation or responsibility.

### *Assessment and validation management*

The IS shall demonstrate how compliance with the ISCP shall be controlled and recorded throughout the Contract. This includes the following subjects:

- Issue, signature and dating of records for each completed operation to assure ENEA that all operations foreseen in the ISCP have been properly performed and controlled;
- Identification and record of each report generated during the performance of any particular operation (e.g. test reports or Nonconformity Reports) and, where possible, identifying improvement opportunities;
- Access to the IS premises, IS personnel and IS completed work activities for third party audit or inspection.

### *Measuring and test equipment*

Measuring and test equipment shall be controlled showing evidence of:

- Equipment identification and calibration status;
- Proper use (range, accuracy, ...) and proper output data format;
- Record of proper calibration.

Test records shall clearly identify any used test equipment and its calibration status.

### *Acceptance and delivery requirements*

The IS shall indicate how, when and by whom acceptance and delivery will be controlled.

### *IS review of the acceptance data packages and IS release note*

Prior to deliveries, the IS should organize a deliverables status acceptance review in accordance with the Contract requirements. This includes at least:

- Review of the documentation to be provided (in accordance with the Documentation Schedule);
- Achievement of the technical requirements or performance test reports;
- Special processes and personnel qualification proof review;
- Review of the records and justification of all changes and derogations (Nonconformity Reports, Deviation Requests, Deviation Proposals and Deviation Orders);
- Configuration status.
- Information about the management of Intellectual Property.

This review is formalized with a formal IS Release Note signed by the ISTRO.

### *Acceptance of deliverables*

ENEA will declare the deliverable conformity by issuing an Acceptance Note. ENEA signature of the Acceptance Note shall not relieve the IS from contractual obligations and responsibilities.

The IS is responsible for any repair when the failure is directly attributable to its manufacturing and processes.

The IS shall ensure that its subcontractors implement the same procedure to control acceptance and delivery.

### *Contract risk management*

The IS shall describe the provisions implemented in order to reduce the Contract exposure to risks regarding the expected performance and time schedule. This includes at least the following subjects:

- Preliminary risk analysis and assessment report in terms of expected performances and time schedule;
- Associated list of actions to implement in order to reduce the risk exposure of the project;
- Plan to upgrade the two previous documents.

### *Health & safety*

In this section the IS shall demonstrate the fulfillment of all the health and safety regulations of the country where the activities will be developed.

The subject of the human safety shall be carefully analyzed by the IS. The human safety must rely on fail-safe and hardware components (mechanical interlocks, grounding connections and switches, circuit breakers, screens, etc.). During the DDP, all the information necessary to design the system in compliance with the safety rules will be given, including detailed information on the JT-60SA safety rules.

A fail-safe logic shall be adopted for the elaboration and transmission of all the alarm/fault signals.

An easy access to all the equipment and components shall be ensured for maintenance and troubleshooting operations.

The entire equipment shall be designed, manufactured and tested according to the IEC safety standards.

### *Codes, regulatory documents and standards*

The ISQP shall reference quality and management applicable codes, standards and regulatory requirements.

The design and construction of the entire equipment shall comply with the best current engineering practices. The concepts of simplicity and reliability shall be essential in the design in order to ensure a long continuous service with minimum maintenance requirements. Modularity shall be used to the maximum possible extent to minimize the time required for maintenance and repair.

Systems, components and design shall be as standard as possible. It is preferred to avoid as far as possible the use of specifically designed components.

All the supplied equipment shall be designed, manufactured and tested in accordance with the most updated issues of the relevant IEC Standards and Recommendations. In particular, the standards explicitly cited in the TS shall be considered.

### *Evolution and revisions of the ISQP*

Written ENEA approval of the updated ISQP is needed before the beginning of the implementation.

The IS shall update the ISQP (or parts of it) each time it is needed and shall submit it for approval to ENEA. The updates shall be approved in writing by ENEA prior to their implementation.

### *ISQP at tender/proposal level*

The IS (as a Bidder) shall provide, in its offer/proposal a meaningful preliminary outline of the ISQP where the plans, schedules and explanation of the provisions to comply with the requirements will be assembled. The basic structure and contents shall be adequate to assess the compliance of the final ISQP with the requirements.

During offer/proposal, due to the nature of the process, the IS might not have all the necessary information. As result of this limitation, at this stage the ISQP cannot be a "complete" version and is referenced as an "outline" version in which some sections will be addressed as a description of the proposed system. The remaining sections shall contain the description of the IS current system.

### *ISQP at contract level*

After the Contract signature (in particular at the Kick-off Meeting) the parties shall agree the improvement of the preliminary ISQP and the particular provisions to be included in it.

The IS shall issue a detailed version of the ISQP at the completion of the DDP for ENEA approval. The IS shall not begin any manufacturing or purchase activity without the ISQP approved in writing by ENEA.

### *ISQP at test level*

The IS shall issue an updated version of the ISQP Plan including the details of the test procedures 2 months before the beginning of the Factory Tests.

### *Visits, inspections and audits*

The IS shall provide ENEA with access to documentation, premises and personnel (including that of its subcontractor's) during all stages of the Contract for the purpose of audit, review, surveillance and inspection.

ENEA reserves the right to make unscheduled visits to the works of the IS or of its subcontractors and free access shall be provided at all reasonable times.

ENEA shall have the right to have permanent inspectors working on the Contract inside the IS's workshops. In this case, the IS shall reserve an office inside its workshops, equipped with a telephone and fax with international access and Internet access.

ENEA can require photographs and record video of anything connected to the pertaining contract (the obtained material shall remain confidential).

ENEA commits itself to keep confidential any other information not linked to the contract that it might have access to during audit and surveillance activities.

### *Audits and surveillance*

Planned and documented audits, reviews, surveillance and inspection of the IS quality assurance arrangements may be carried out by ENEA or their appointed representatives to verify compliance with all quality and technical aspects of the Contract.

These activities may be extended to the IS's subcontractors. Regarding any deficiencies found, the IS shall implement or ensure that the subcontractors implement corrective actions in accordance with an agreed time-scale.

ENEA shall be informed of the IS audits, reviews, surveillance and inspection activities, including those involving subcontractors. Notifications shall be in writing, preferably via fax or email.

If on-site inspection services exist, the notification shall be sent directly to them well in advance. In this case, only ENEA shall be notified in writing of the points identified as hold points within the timeframe stipulated in the above paragraph.

The IS shall be responsible for all expenses derived from ENEA inspections or audits as a result of wrong notifications. When ENEA is not able to witness an activity considered important as a hold point, ENEA may request to repeat such activity at its own expense. Moreover, ENEA is responsible for the temporary stops of the activities.

### *Access of ENEA observers*

ENEA shall have the right to be accompanied by observers to the agreed surveillance and audits visits. These observers will be identified in advance and agreed with the IS and will belong to ENEA, F4E or JAEA. All the observers shall be bound by appropriate confidentiality obligations to be agreed in advance.

### *Third party inspection authority*

ENEA may, for the purpose of this Contract, appoint an independent inspection authority to certify that activities are carried out in accordance with the agreed codes and standards.

The IS shall arrange free access for the inspector(s) to its works or at the works of its subcontractor's, so that the inspector(s) may carry out its duties as described. The IS shall provide the inspector(s) with copies of all relevant test reports and other facilities, as may be necessary, so that he is able to certify that deliverables meet the technical requirements.

### Summary of Contract documentation

The Contract documentation shall include as a minimum all the documents described in the TS and in the MQS. They are summarized in Table 14 and described in the following subsections.

**Table 14: List of main Contract documents with deadline/periodicity.**

Document		Deadline/periodicity
Procurement description		In the offer/proposal
First Design Report		End of the DDP
List of recommended spares (see TS Section 4.10.8)		End of the DDP
ISQP	Preliminary	In the offer/proposal
	Detailed (contract level)	With First Design Report
	Test level	2 months before starting tests
	Update	Every time it is necessary (especially Risk Management and schedules)
Detailed Testing Plans (for Factory Type and Routine Tests)		3 months before starting tests
Invitation to tests attendance (with definitive dates)		2 weeks before starting tests
Test Reports		45 days after the tests
Specifications for Handling and Transportation		10 months before shipping to Japan
Block and functional schemes of the control system		1 month before SNU delivery
Site Installation Plan		6 months before SNU delivery
Site Commissioning Program		3 months before SNU delivery
Operation and Maintenance Manual		1 month after SNU delivery
Drawings		6 weeks after SNU delivery
Source code		6 weeks after SNU delivery
Final Report		End of activities (last Contract phase)
Progress Reports		Every 30 days
Invoices/receipts/documents for Contract payments		End of each Contract phase

Table 14 do not include the legal and financial documents prescribed by the Invitation Letter and by the Italian laws to participate to the Call for Tender procedure and to sign the Contract with ENEA. Moreover, the IS shall comply with any other applicable Italian and European law, prescription or regulation.

### ISQP

The ISQP shall be in agreement with the guidelines defined in previous sections.

### Progress Reports and Meeting Minutes

Progress Reports shall be prepared and sent monthly to ENEA, reporting in particular on:

- Main scheduled work packages and milestones;
- Main results, completed activities, achievements and issues encountered in the last month;
- Proposed deviations and raised nonconformities with their acceptance status;
- Main scheduled work packages and milestones for the coming month;
- Issues and actions from the last month or previous months.

The IS shall organize the Progress Meeting and shall be responsible to issue the minutes of these meetings.

### First Design Report

The First Design Report shall demonstrate the full compliance with the TS. It may be either a single document covering the whole scope of the Contract or an assembly of separate and well-identified documents covering all the technical aspects related to this Procurement.

The contents of the First Design Report shall include at least:

- Detailed design description of the power section and the selection of rating and type of the major components, including voltage and current transducers, passive components and cables, their main data and/or data sheets (for standard components) and relevant tolerances.

- Layout drawings shall be provided showing the location of the various cubicles of each SNU, the position of the components inside each cubicle, including the voltage and current transducers. The layout shall comprise dimensions, weights and a description of the enclosures.
- Detailed design description of the control system, with block diagrams showing the main functional blocks and the flow of the various signals, the data of the main components used in the control, the list of the exchanged signals.
- Analyses of the SNU operation in normal conditions, including the calculations and studies on the integration of the various components. In particular, the calculations used to estimate the transient voltages and currents during current commutations, the maximum temperature reached by all temperature-critical devices shall be provided. For the SCB, the conduction and commutation losses shall be calculated and the junction temperature shall be evaluated using a reliable model including the characteristics of the cooling system and heat sinks. In case of parallel and series devices, a full report shall be given on the studies and tests performed to ensure correct current and voltage sharing in all the operative conditions.
- Analyses of the SNU operation in anomalous condition. The IS shall provide a table of fault conditions, which lists the fault events, their detection, the related protection (main and back-up), the related alarms and monitoring. An analysis of the stresses on the components shall be given for every severe fault and shall include all the related calculations and simulations. The effectiveness of the protective actions shall be demonstrated. Faults involving the danger of fire or explosion shall be clearly identified and described.
- The explosion  $I^2t$  for all semiconductor devices shall be identified and actions to prevent damages arising from semiconductor explosion shall be defined.
- A preliminary list of tests to be performed at factory, including individual tests on the components, Factory Type Tests, Factory Routine Tests and a description of the IS test facilities. The IS shall indicate which tests cannot be performed at its premises and shall propose alternative arrangements for their execution.
- Preliminary information regarding the site installation requirements.
- Preliminary information regarding the maintenance requirements and procedures.
- A list of reference standards used for the design of the system shall be given.

### *Factory test plan and procedures*

The IS shall complete and update the list of factory tests included in the First Design Report. The IS shall provide a detail description of the test procedures to be performed, the acceptance criteria and the time schedule for each test. The overall test schedule shall include, if any, tests that are performed outside the IS premises.

### *Site Installation Plan*

A sequence of assembly, installation and commissioning activities with related detailed time schedule shall be provided by the IS. The final version shall be approved by ENEA prior to shipping of the equipment.

### *Site Commissioning Program*

The IS shall provide a Site Commissioning Program detailing the test procedures to be performed, the acceptance criteria and the time schedule.

### *Test reports*

The IS shall provide written records of all the performed tests. The test reports shall be provided within 45 days after the relevant tests have been performed. The test reports shall clearly report the results of the tests, which shall be compared with the requirements given in the technical specifications.

### *Operation and maintenance manual*

The IS shall provide an Operation and Maintenance Manual including, but not limited to:

- Operation procedures;
- Maintenance instructions, including calibration and adjustment procedures;
- Guide to check and troubleshooting operations in case of faults or alarms.

### *Specifications for non-standard component*

For non-standard components, beyond the traceability information, the technical specifications prepared for their procurement shall be provided.

### *Block and functional schemes of the control system*

Comprehensive information shall be provided for each electronic card included in the supply, sufficient to understand the card operation and to perform the necessary measurements. Expected levels and/or waveforms at the various test points shall be included.

### *Drawings*

One set of reproducible drawings of the equipment shall be supplied. A complete cable and connection scheme shall be included.

### *Source code*

The source code of any software used for PLCs, microprocessors, PLDs or other programmable devices shall be provided, together with sufficient documentation and software tools to modify the operation of the programmable device.

### *Import documents*

The IS shall provide all the documentation necessary to import the components in Japan and to obtain any required local clearance.

### *Final documentation*

After the final acceptance, the IS shall issue a Final Report (or Final Design Report), including and reviewing all the documents, information and drawings provided during the Procurement. The Final Report includes all the information requested in the First Design Report and may review and update it where necessary.

The Final Report shall contain also the following information:

- Summary of the Contract;
- Collection of all the Contract minutes and reports;
- Final Contract schedule;
- Final Contract ISQP;
- Final ISCP;
- Summary of the results, including tests and calculations;
- Copies of all as-built drawings, including CAD models where applicable;
- Full photographic record of the manufacture.

The IS shall provide the Operation and Maintenance Manual including, but not limited to the Operation Procedures, the Maintenance Instructions, including calibration and adjustment procedures, the Check in case of Fault Indication.

The IS shall provide the source code of any software used for PLC, microprocessor, PLD or other programmable device, together with sufficient documentation and software tools to modify the operation of the equipment.

### *Document format*

All communications and official documentation shall be in the standard project language. In particular:

1. For monolingual documentation, the language shall be English;
2. For dual-language documentation (regulatory or safety documentation requirements), the original and reference text shall be in English and all interpretations of it will be based on the English text. In the event of a conflict between different translations, the English text will prevail. The layout to be used is a dual-column page, where both versions of the document are in parallel, with English in the left column.

The documentation shall be provided in standard formats and shall be delivered both in electronic and in hard-copy versions (3 hard-copies and 5 CDs/DVDs are requested).

The formats of the provided electronic files shall be authorized in advance by ENEA. The formats in Table 15 can be accepted without explicit authorization.

In case of a newer version of a software is adopted, it must be agreed with ENEA.

The additional costs necessary to manage a new file format or a new release of a software shall be covered by the IS.

For specialized engineering calculations and simulations, fully useable data input and output files shall be provided. The source code shall contain proper comments as allowed by the programs.

The editable/modifiable files shall be accompanied by the reverence and informative files in Portable Document Format (PDF).

In order to reduce the amount of files, documents that belong naturally to a set shall be zipped in one electronic file. The zipped archive shall contain an additional file with title page listing the contained files.

A list of files describing the current status of the Contract documentation shall be maintained in spreadsheet format.

**Table 15: Acceptable file formats.**

File type	Editable/modifiable format
Text document	Microsoft Word (.doc)
Spreadsheet (including Documentation Schedule, ISCP, and so on)	Microsoft Excel (.xls)
Presentations	Microsoft Power Point (.ppt)
Schedules, Plans	Microsoft Project (.mpp)
CAD models and drawings	AutoCAD 2009 3D/2D (.dwg / .dxf)
Scans and pictures	JPEG
Movie	Audio Video Interleave
Circuit simulation	Powersim PSIM

### *Summary of Contract activities*

During the first phase of the procurement contract, a Detailed Design Phase shall be performed. Consequently, a First Design Report shall be issued by the IS for ENEA approval.

The First Design Report may be a single document covering the whole scope of the Contract or an assembly of separate and well-identified documents covering all the technical aspects related to this procurement. The First Design Report explains the technical solutions selected to comply with the requirements of the specifications. This detailed design shall include a full analysis of the system in both normal and abnormal conditions, the manufacturing drawings, the scheduling for the execution of the procurement, a preliminary list of the tests to be performed at factory, preliminary information regarding the site installation requirements and a list of reference standards used for the design. This report shall demonstrate the full compliance with the TS. The minimum contents of the First Design Report are listed in Section 9.3.1 of the TS.

The IS shall provide in due time for the First Design Report the ISQP containing its manufacturing ISCP.

It is useful to stress that ENEA will issue its First Design Report (based on the information received and agreed with the IS) for the approval of both F4E and JAEA. The agreed First Design Report shall be considered as a part of the Procurement documentation.

The IS shall manufacture the SNU prototype according to the Procurement TS and to the First Design Report.

The IS shall run the Factory Type Tests as described in Section 5.11.2 of the TS in its works (or in the works of a sub-supplier) unless this is not possible. In this case, the tests shall be carried out in another suitable test facility agreed between the ENEA and the IS.

The ISQP shall include a detail description of the test procedures to be performed, the acceptance criteria and the time schedule for each test. The test schedule shall include, if any, tests that are performed outside the IS premises.

ENEA will send a Detailed Testing Plan to F4E before starting the tests. The invitation to attend the tests including the definite test dates will be distributed to all the potential witnesses before starting the tests.

The IS shall provide written records of the performed tests.

After the successful conclusion of the Factory Type Tests, the IS shall substitute the stressed components at its own expenses, in order to ensure that the unit will be able to sustain its nominal life.

The IS shall manufacture the 3 remaining SNUs according to the First Design Report.

The IS shall run the Factory Routine Tests in agreement with the ISQP and with Section 5.11.3 of the TS.

Factory Routine Tests shall be performed in the IS's works, in the works of a sub-supplier or in another suitable test facility agreed between ENEA and the IS.

The Factory Routine Tests shall ensure that the supplied equipment meet the requirements of the specifications.

Factory Routine Tests shall include also all the routine electrical, mechanical and hydraulic tests, in accordance with the relevant IEC Standards and the tests listed in the specifications. Moreover, the Factory Routine Tests will include any additional test agreed between ENEA and the IS during the DDP. For the equipment not covered by any IEC standard and not specifically mentioned in these specifications, the tests shall be agreed with ENEA during the DDP.

The invitation to attend the tests including the definite test dates will be distributed to all the potential witnesses before starting the tests.

The IS shall provide written records of the performed tests.

The IS shall be responsible of packaging and shipping of all the procured components to the Port of Entry (PoE) in Japan (see Section 7 of the TS). Currently, JAEA indicated Yokohama or Tokyo as the first priority of PoE in Japan and defined the acceptable sizes and weight for the packages to be transported by road [3].

The IS shall be responsible for the transport, including packaging, handling and storage during the transport, of its contributions to the PoE in Japan. JAEA shall be responsible for transport, including handling and storage, during the transport from the PoE to the Naka Site [3].

The IS shall issue the "Specifications for Handling and Transportation" of all the procured components, including, at least, the dimension and weight of each transported package and the detailed instructions to properly handle and transport each package.

The IS shall be covered by an insurance at its care and expenses. The IS shall provide evidence of the existence of the insurance.

Due to the agreements between ENEA and F4E, ENEA needs a specific documentation concerning the costs related to the transportation including the insurance. The IS shall provide detailed quotations of such costs (including evidences, if necessary) according to the forms required by ENEA.

In any case, the IS shall maintain the full responsibility of the procurement. For this scope, the IS shall include in each package any stress sensor and provision to effectively monitor and verify that the package itself and anything included is substantially sound.

The sub-components forming the overall supply of the SNUs and their parts shall be packaged respecting the indicated limits. It is assumed that standard limits will be respected. If any deviation is foreseen, this shall be agreed with ENEA and JAEA at least 18 months before the transport to Japan.

The packaging must provide adequate mechanical and environmental resistance to road and transoceanic ship transport. The packaging must provide adequate attachments for loading and unloading by crane or equivalent lifting/moving tools and for its stable fixation on trucks and ships.

Packaging materials shall be in agreement with JA rules and with international sanitary rules (i.e. the use of wood requires the corresponding phyto-sanitary certificate...). Packaging shall be made and managed in order to avoid and prevent contact of the components with any contaminant agent.

The packaging must ensure clear identification of the transported components.

The packaging of the ready-for-shipment components shall be inspected at the manufacturer premises to verify the respect of the requirements for transport. The inspection shall consist in a visual verification of the packaging and in a review of the formal and technical documentation for transport. The inspection and documentation verification shall be performed at the presence of representatives of the IS, of ENEA and of both the IAs. An official note of the inspection shall be prepared and approved by the present representatives.

The handling shall be performed according to procedures minimizing the risks of damage to the components.

The storage shall prevent any possible contact with any contaminant agent.

The components forming the contribution to the JT-60SA system shall be delivered in numbered and identified packages.

The IS shall identify all the components by a metallic or plastic plate attached to the component, in which the identification code (IDC) is written.

This IDC shall correspond to the name of the component that will be indicated by ENEA during the DDP. The same name shall be used in the technical documentation.

During the DDP, the IS shall propose a list of the components needing traceability. This list will be discussed and approved by ENEA. The list shall include all the components/sub-systems whose failure could imply an out-of-service of the SNUs.

The IDC plate attached to a component belonging to this list shall also contain the serial number. The serial number shall allow the identification of the record containing information about the traceability of the component.

For the more standard components, not included in this list, the IS shall indicate however the necessary information for their easy procurement.

Records of the traceability of each component shall be stored and kept by the IS for at least 10 years (or the regulatory period of time, if longer). The records shall contain all the information to recognize the production process, utilized material, manufacturer, etc.

The Road and ship transports have to be performed using the most appropriate carriers in order to guarantee component safety and delivery on time.

The IS shall provide all the documentation requested by the Local Authorities to deliver the components in JA.

At the arrival of the ship in the PoE, the packaging containing the components ready for unloading shall be checked after the ship unloading (DEQ, referring to INCOTERMS 2000).

The check shall consist in:

4. Visual verification of the packaging;
5. Check of shock recorder and/or acceleration sensor prepared to monitor shock and vibration during the transport;
6. Check of all the requested administrative documentation.

The check, the monitoring record and documentation verification shall be performed at the presence of representatives of the IS, of ENEA and of both IAs. An official note of the check shall be prepared and approved by the representatives.

The design of the SNU system shall be compatible with the JT-60SA layout and with the provided information.

The JT-60SA interfaces are widely presented in the PID. The IS shall particularly take care of all the information concerning the integration of the SNUs in JT-60SA (see in particular Section 4 of PID. Fig. 8 of the TS, coincident with Figure 2.7-6 in the PID, shows the interfaces of each unit of the coil power supplies with respect to the rest of JT-60SA systems. Fig. 9 of the TS is focused on the SNU interfaces and on the boundaries between the EU and the JA procurements. The IS shall consider the interfaces addressed in Section 4.7 of the TS.

After the final acceptance, the IS shall issue the Final Report and the related documentation, as described above.

The IS shall provide training for the JT-60SA operating staff, in the operation, maintenance and troubleshooting of the supply.

Training shall include all the items described in Section 9 of the TS.

All the components shall have a warranty for defects in the manufacture for a period of 2 years starting from the acceptance of the components. The warranty is limited to the direct costs of repair or remanufacturing of the components. Any other warranty is excluded.

Some extensions could be requested by ENEA, as described in the TS. In particular, the IS shall provide within this Procurement a basic set of spare parts, as indicated in the TS. Moreover, during the DDP, the IS shall provide a list of recommended spares that could be ordered by JAEA to cover the equipment specified

operational life, beyond the warranty period. This list shall include the individual prices and an indication of their time validity. This list could be used by F4E to request an extension of the standard commercial warranty or a supply of spare parts. This option can be exercised, at the price proposed in the list, until the delivery of the Procurement. The spare list can be changed in order to purchase fewer or more parts with no cost variations. The preparation of the described list will not relieve the IS from its obligations.

The IS shall provide information and, preferably, evidences on the reliability of the offered equipment. The IS shall indicate the times necessary for the substitution of the main components in case of faults. The IS shall provide a realistic assessment of the necessary maintenance requirements over the first 10-year period of operation.

**Stato del Contratto di fornitura degli SNU**

La Fig. 17 è tratta dalla presentazione tenuta dalla Task Force ENEA durante il Technical Coordination Meeting (TCM-15) di JT-60SA tenutosi a settembre 2012. La figura riassume lo stato della fornitura degli SNU con particolare riguardo alle prime attività.

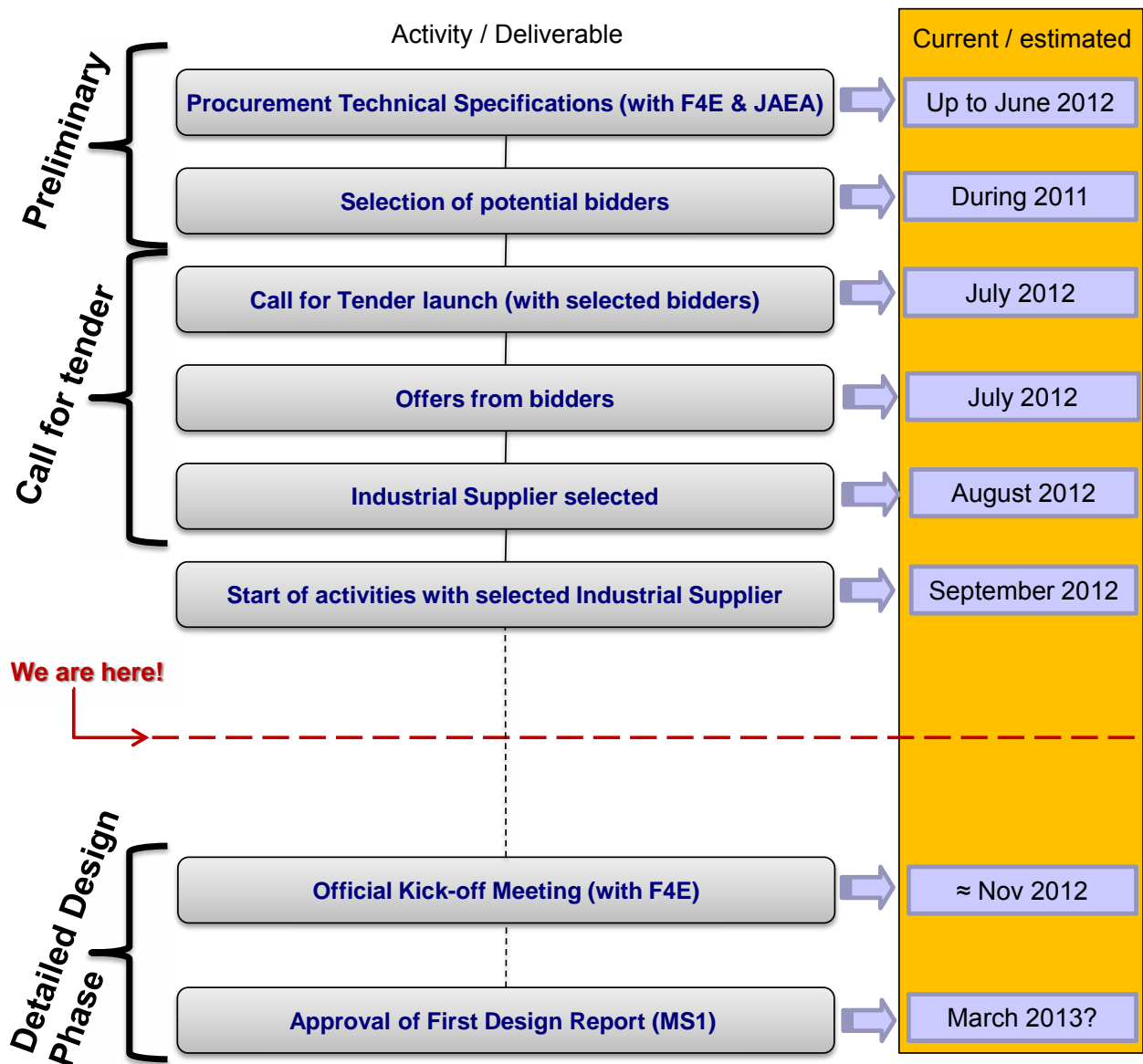

Fig. 17: Stato della fornitura dei 4 SNU dei CS di JT-60SA.

Sulla base delle specifiche tecniche, gestionali e di qualità, degli allegati facenti parte del BA e della documentazione legale richiesta, la Commissione nominata dall'ENEA ha svolto le procedure per la selezione del fornitore industriale (IS) per l'esecuzione finale degli SNU. Al momento della redazione del presente rapporto (settembre 2012), l'impresa Energy Technology S.r.l. di San Giorgio di Piano (BO) risulta in aggiudicazione definitiva ed efficace per la procedura suddetta.

L'Unità di Ingegneria Elettrica ed Elettronica dell'ENEA ha iniziato a discutere e valutare le soluzioni tecniche prodotte dalla ditta aggiudicataria. In queste attività sono coinvolti anche F4E e JAEA.

Allo stato dell'analisi, le soluzioni tecniche proposte dall'impresa aggiudicataria rispondono ai requisiti tecnici richiesti dal sistema.

## Conclusioni

Il lavoro svolto all'interno dell'Accordo di Programma, avente come obiettivo la realizzazione di 4 SNU del tokamak giapponese JT-60SA, sta procedendo secondo i Piani Annuali di Realizzazione (PAR), raggiungendo gli obiettivi prefissati. È utile osservare che la realizzazione del progetto JT-60SA sta subendo alcuni ritardi, in particolare per quanto riguarda le alimentazioni elettriche. Tali ritardi sono perfettamente comprensibili data la complessità e l'internazionalità del progetto e sono comunque sotto il controllo del gruppo di coordinamento internazionale.

Durante il periodo di riferimento (ottobre 2011 - settembre 2012) sono stati finalizzati tutti i documenti e gli adempimenti necessari al progetto degli SNU ed alla relativa Call for Tender, in conformità alle leggi italiane, alle direttive europee, gli standard di qualità ed agli accordi BA, PA e AoC.

Le attività sono state costantemente concordate con i partner internazionali, in particolare con F4E e JAEA. Utilizzando la documentazione e le informazioni derivate dalle precedenti attività, l'ENEA ha completato le procedure per la selezione del fornitore industriale (IS) per l'esecuzione finale degli SNU. Basandosi anche sui documenti e sulle informazioni prodotte dall'ENEA, ma con procedure indipendenti, l'agenzia giapponese JAEA ha commissionato ad un'altra impresa italiana 2 ulteriori SNU per gli avvolgimenti EF di JT-60SA, con caratteristiche simili a quelle degli SNU forniti da ENEA.

L'Unità di Ingegneria Elettrica ed Elettronica dell'ENEA ha iniziato a discutere e valutare le soluzioni tecniche prodotte dall'IS.

Le soluzioni tecniche previste dall'ENEA e, preliminarmente dall'IS, sono idonee a realizzare le elevate prestazioni richieste agli SNU di JT-60SA e quindi di consentire la formazione del plasma per lo studio della fusione nucleare.

## Riferimenti bibliografici

1. Procurement Technical Specifications for the Agreement Of Collaboration F4E-ENEA for the Joint Implementation of the Procurement Arrangement for the Supply of the Switching Network Units for Central Solenoids for the Satellite Tokamak Programme (TS).
2. Plant Integration Document (PID).
3. Definition of SNU PoE in Japan.
4. Management and Quality Specifications for the ENEA Industrial Supplier (MQS).
5. Withstand-to-ground voltage testing.
6. JT-60SA Power Supply, Summary of Signals to be exchanged among each components and magnet PS supervising controller.
7. Address map of RM for PS control system.
8. Power Supplies Installation Works at JT-60SA Site – General Conditions for EU-Suppliers.
9. Services at Naka Site for Installation.
10. Regulations at Naka Site for Installation.
11. JT-60SA Power Supply System Recovery Sequence in Case of Fault.
12. JT-60SA Integrated Project Team Common Quality Management System.
13. JT-60SA EU Home Team Quality Management System.

## Abbreviazioni ed acronimi

Acronimo	Termine	Definizione
AoC	Agreement of Collaboration	Framework between F4E and VC-DI to reinsure its commitments towards JAEA under the Procurement Arrangements
BA	Broader Approach	Agreement between the Government of Japan and the European Atomic Energy Community for the joint implementation of the activities in the field of fusion energy research
BPS	By-Pass Switch	Electromechanical device that conducts the coil current before and after the breakdown phase in the reference scheme
CBU	Crow-bar Unit	Electrical circuit used to prevent an overvoltage of a power supply
CRL	Current Reversing Link	Links inserted in the PSs to reverse the polarity of the magnetic field
CS	Central Solenoid	Nb <sub>3</sub> Sn conductor consisting of 4 independent modules
CT	Current Transducer	Transducers for current measurements in the SNU
DDP	Detailed Design Phase	In this phase, the IS shall detail the technical solutions selected to comply with the requirements
DEMO	DEMO	DEMONstration Power Plant intended to build upon the success of ITER
DMS	Document Management System	BA Document Management System (also known as IDM)
ECRF	Electron Cyclotron Radio-Frequency	Electron Cyclotron Radio-Frequency system for additional heating
EF	Equilibrium Field	Equilibrium Field (coil)
EMC	Electromagnetic Compatibility	Correct operation of different objects in the same electromagnetic environment
ENEA	ENEA	Italian National Agency for New Technologies, Energy and Sustainable Economic Development
EU	EU	Europe
F4E	Fusion for Energy	European joint undertaking for ITER and the Development of Fusion Energy: integral part of the JT-60SA Project EU Home Team ensuring the coordination of implementation of the PA and its interfaces with other PAs in BA activities
FPGA	Field Programmable Gate Array	Integrated circuit designed to be configured by the customer or designer after manufacturing
FPPC	Fast Plasma Position Control	Coils used to control the plasma position
GPS	Global Protection System	System for handling the protection signals received from the equipment and distributing the protection commands

GS	Grounding Switch	Switches for SNU safety grounding
HMI	Human Machine Interface	Hardware/software for friendly high-level management
IAs	Implementing Agencies	F4E and JAEA
IDC	Identification Code	Code used for identification and traceability of JT-60SA components
IGCT	Integrated Gate Commutated Thyristor	Power semiconductor electronic device used to switch electric current
IP code	International Protection code	International Protection rating code as defined in Standard IEC 60529
IPS	Internal Protection System	System to coordinate protective actions among all JT-60SA PS components and among them and the remaining parts of the JT-60SA system
IS	Industrial Supplier	The company selected by ENEA to provide the supplies, services or works described in these Technical Specifications, according to a Procurement Contract
ISCP	Industrial Supplier Control Plan	A relevant part of the ISQP
ISQP	Industrial Supplier Quality Plan	The Quality Plan issued by the IS according to the guidelines provided by ENEA in the present document
ISQR	Industrial Supplier Quality Representative	Quality Representative of the IS for the Procurement Contract
ISTRO	Industrial Supplier Technical Responsible Officer	Technical Responsible Officer of the IS in charge for the Procurement Contract
ITER	ITER	International research and engineering project which is currently building the world's largest and most advanced experimental tokamak nuclear fusion reactor
JAEA	JAEA	Japan Atomic Energy Agency
JT-60SA	JT-60SA	JT-60 Super Advanced tokamak, the construction and exploitation of which shall be conducted under the Satellite Tokamak Programme and the Japanese national programme
LCC	Local Control Cubicle	SNU Local Control Cubicle
LCM	Local Control Mode	Local Control Mode of the SNU operations
LSOHFR	Low Smoke, Zero Halogen, Fire Retardant	Type of insulation for cables and optical fibers
MQS	Management and Quality Specifications	Management and Quality Specifications for the ENEA Industrial Supplier
MS	Making Switch	Switch able to insert the second resistance R2 to support the plasma breakdown phase
NBI	Neutral Beam Injector	Positive (P-NBI) and negative (N-NBI) neutral beam injectors for additional heating
PF	Poloidal Field (coil)	In a tokamak, the poloidal field travels in circles orthogonal to the toroidal field

PID	Plant Integration Document	Document defining the technical basis of the JT-60SA Project
PoE	Port of Entry	Port of Entry in Japan
PA	Procurement Arrangement	Framework between F4E and JAEA for the main governing, financial and collaborative requirements for the supply of a procurement package
PS	Power Supply	–
PS SC	Power Supply Supervising Computer	Computer provided by JAEA that communicates with SCSDAS, GPS and SIS and includes an IPS
PSV	Vertical power supply	Vertical field coil power supply already present in JT-60U
QPC	Quench Protection Circuit	System to protect superconducting coils
RCM	Remote Control Mode	Remote Control Mode of the SNU operations
RM	Reflective Memory	Real-time Local Area Network in which each computer always has an up-to-date local copy of the shared memory set
rms	Root Mean Square	Standard Parameter of an alternating electrical quantity
RWM	Resistive Wall Mode	Issue related to plasma stabilization
SCB	Static Circuit Breaker	Switch system based on static devices that supports the BPS to satisfy the time specifications
SCSDAS	Supervisory Control System and Data Acquisition System	JT-60SA system
SIS	Safety Interlock System	JT-60SA system
SNU	Switching Network Unit	The main object of this Procurement
SS	Fast SNU Switch	Functional component of a SNU, that can be implemented by several physical devices, able to divert the coil current to a specific set of resistors
STP	Satellite Tokamak Programme	One of the three projects in the BA activities with the purpose to develop JT-60SA
TF	Toroidal Field (coil)	In a tokamak, the toroidal field travels around the torus in circles
TS	Technical Specifications	The Procurement Technical Specifications for the Supply of the Switching Network Units for Central Solenoids for the Satellite Tokamak Programme
UID	Unique Identifier	Code identifying a DMS document with current status, version, and so on
VC-DI	Voluntary Contributor Designated Institution	Institution appointed by the Government of the countries (Voluntary Contributors) that give voluntary contributions to Euratom for the implementation of the BA activities
XFMR	Transformer	–