



Agenzia nazionale per le nuove tecnologie,  
l'energia e lo sviluppo economico sostenibile



RICERCA DI  
SISTEMA ELETTRICO



MINISTERO DELLO SVILUPPO ECONOMICO

Accordo di Programma MiSE-ENEA

# Ricarica Flash per TPL

Tecnologie per la mobilità elettrica



UNIVERSITÀ  
DEGLI STUDI  
FIRENZE



Roma, 13/12/2018



- Le problematiche della ricarica dei bus elettrici
  - Lato veicolo
  - Lato infrastruttura
- I vantaggi di un accumulo a terra.
- La ricarica flash
  - Caratteristiche a bordo
  - A terra
- Il prototipo e la sperimentazione

## ■ Arch. A:

- Ricarica lenta al **deposito** (max 6/8 h/giorno)
- **Accumulo** agli ioni di litio
  1. **dimensionato** sul consumo energetico della linea nella **giornata più onerosa**
  2. **standardizzato a 350 kWh**



## ■ Arch. B:

- Ricarica lenta al deposito (max 3h/giorno) e **biberonage al capolinea** con pantografo (max 8'/sosta)
- **Accumulo ridotto** agli ioni di litio, **standardizzato** in funzione della dimensione del veicolo (70 kWh per bus 12 m)



## ■ Arch. C:

- **Ricarica** lenta al deposito (max 1h/giorno), veloce al capolinea (max 4'/sosta) e **ultrarapida alle fermate** (20'' per bus articolati, 15'' per tutti gli altri)
- **Accumulo** principale **molto ridotto** a supercaps, accumulo di riserva e per gli ausiliari agli ioni di litio, entrambi **standardizzati** in funzione della dimensione del veicolo



Alle alte potenze di ricarica/tanti autobus contemporaneamente in carica:

- Problematiche per la disponibilità di potenze elevate e per tempi brevi
- Necessità di un accumulo a terra
- Diverse possibili architetture di accumulo in funzione della tipologia di ricarica
- Per la ricarica flash: l'accumulo più idoneo sono i supercondensatori

# Benefici dell'accumulo a terra (ricarica al capolinea)

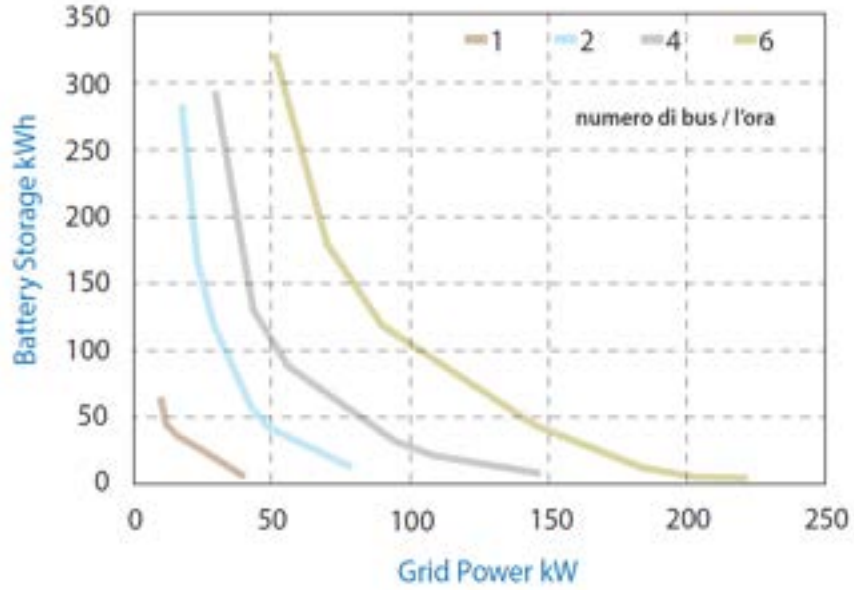
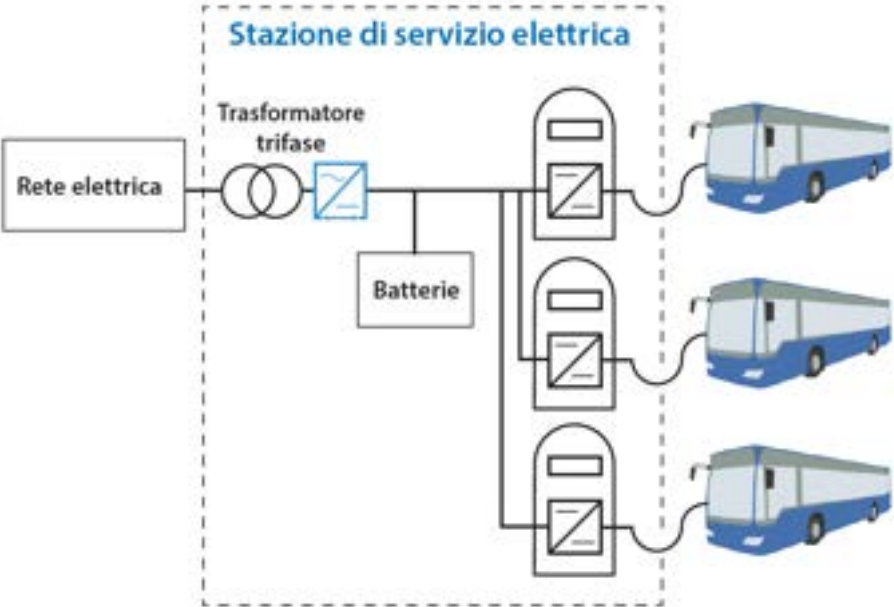

# Alcune Realizzazioni di ricarica alla fermata

It is a new form of electric bus powered via energy stored in large onboard super-capacitors. A connector in the roof connects to the stationary electrical installation when the bus stops to let the passenger on to the bus.

- Electric Bus Technology
  - Super / Outer Capacitors (Energy Storage device)
  - Collector (fitted on the top)
- Super capacitors can be charged much faster than batteries, but hold less energy (at the current time).



TOSA ABB, (Ginevra)

Capabus (Aowei Technology Development Company & Sinautec, Shanghai)

# Architetture di stazione per ricarica alla fermata simulate

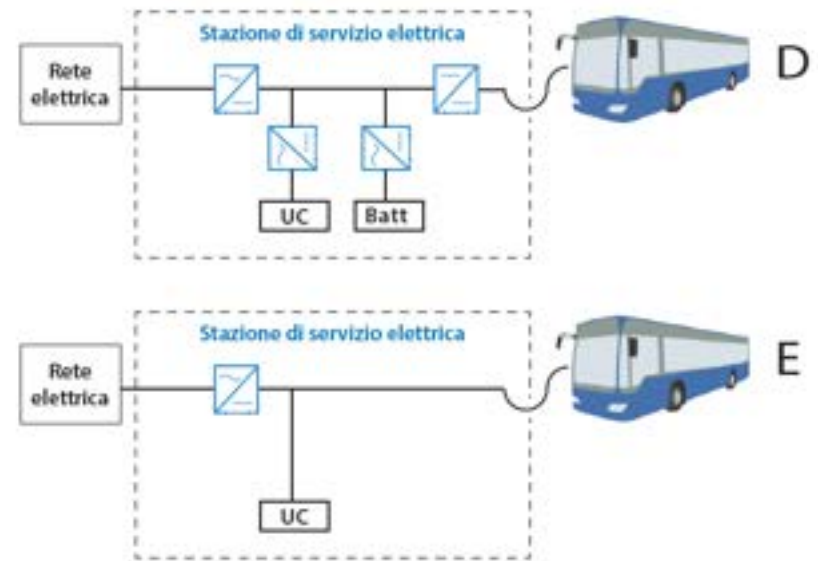
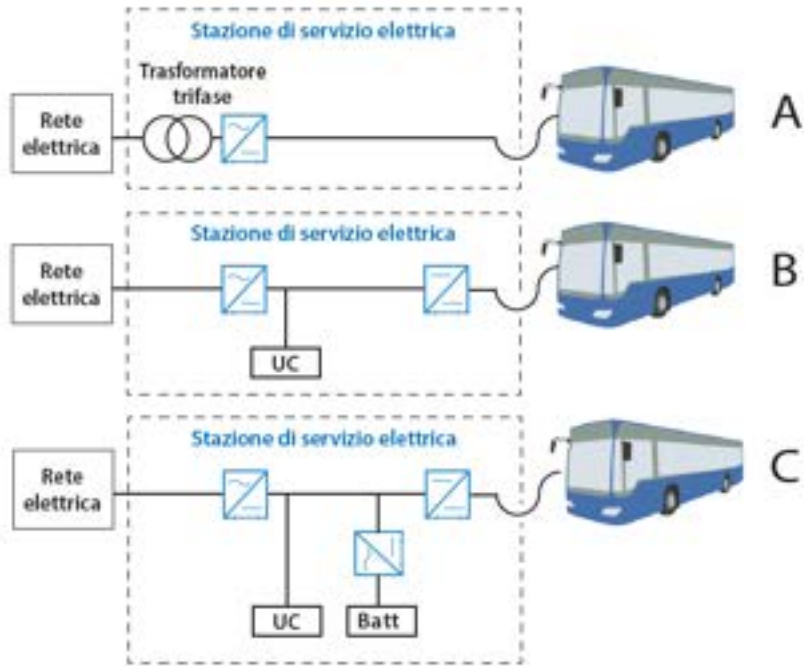

# Valutazione economica delle diverse architetture

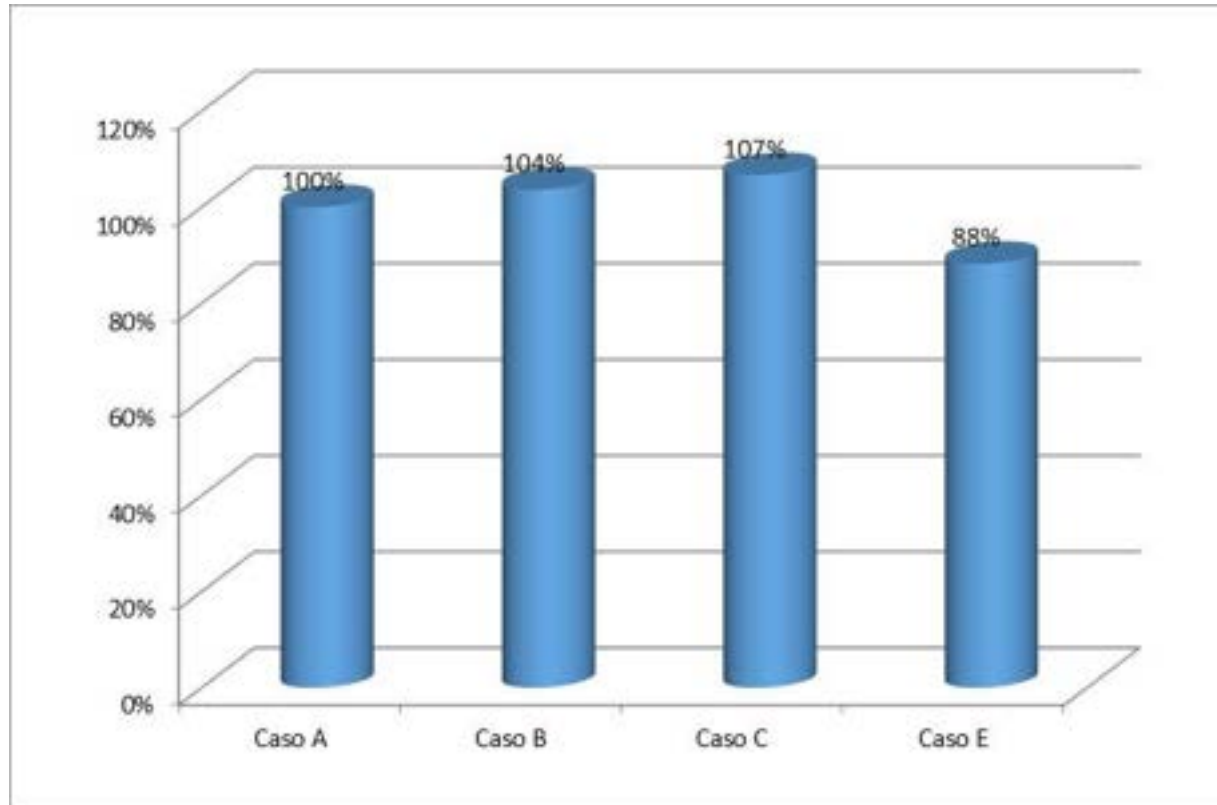

- La stazione non è dotata di convertitore per modulare la ricarica
- La ricarica avviene per travaso di carica tra Supercondensatori a terra (carichi) e a bordo (scarichi)
- I supercondensatori a terra vengono opportunamente collegati per effettuare 3 step di ricarica a tensione crescente
- L'unico oggetto che limita il picco di corrente è una induttanza opportunamente dimensionata

# Ricarica Flash: Prototipo in scala ridotta

Moduli Maxwell 16V e 250 F e induttore 4 mH

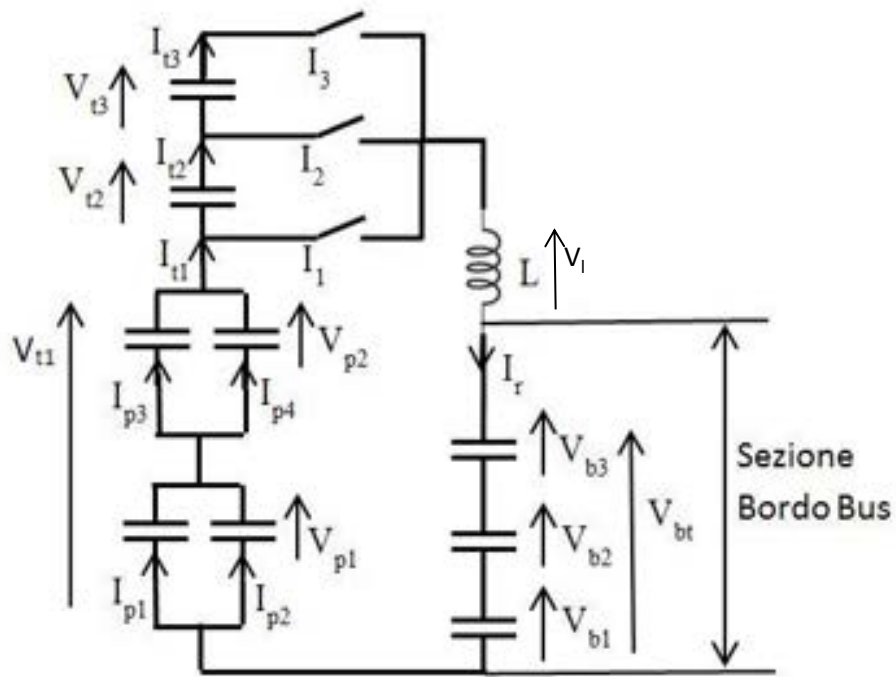

## Confronto tra dati misurati e calcolati da modello di simulazione

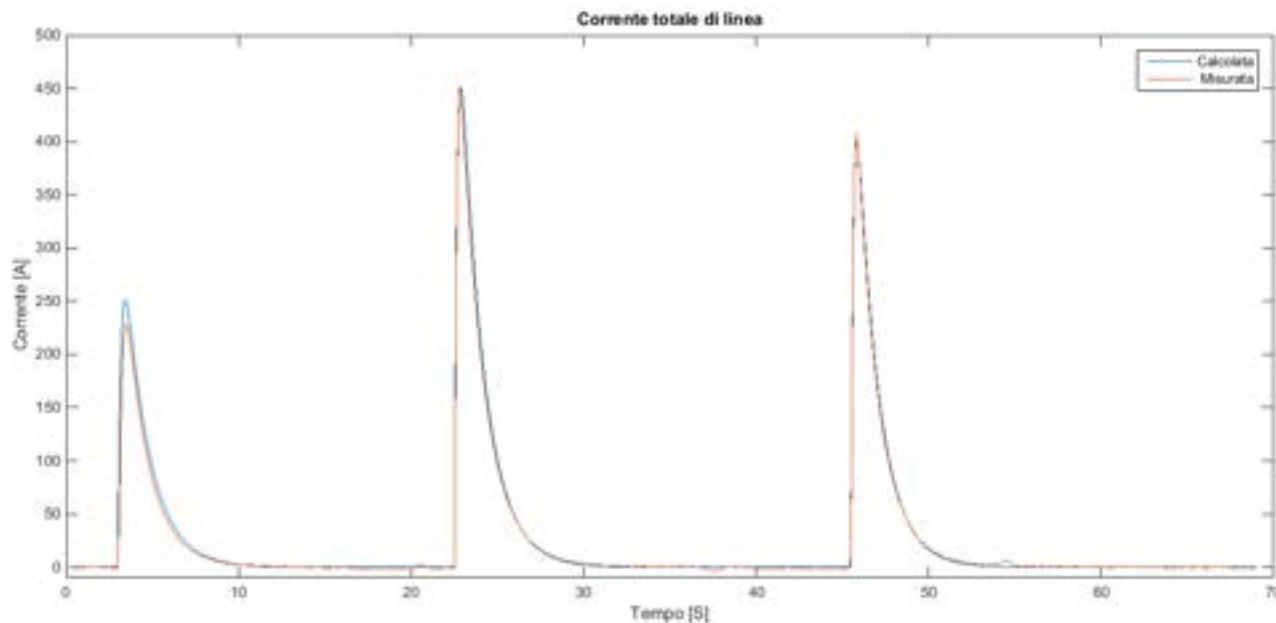

# Ricarica Flash: Sistema in scala reale

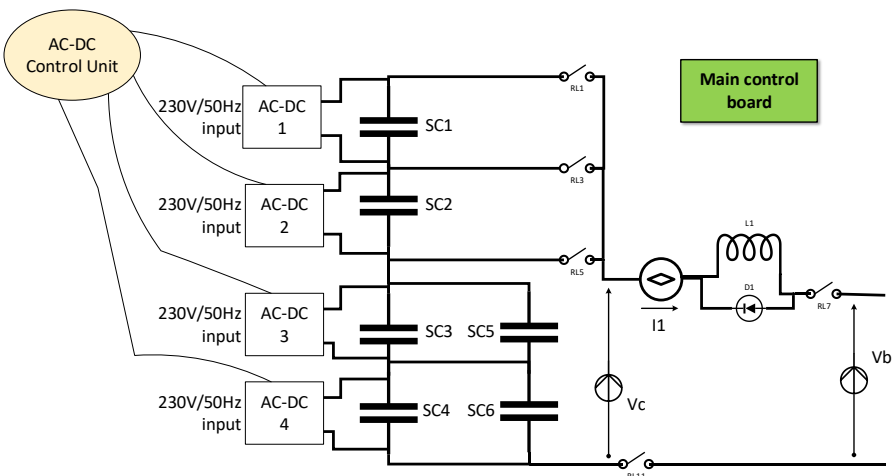

Quando la corrente scende al di sotto di un certo valore si passa allo step successivo

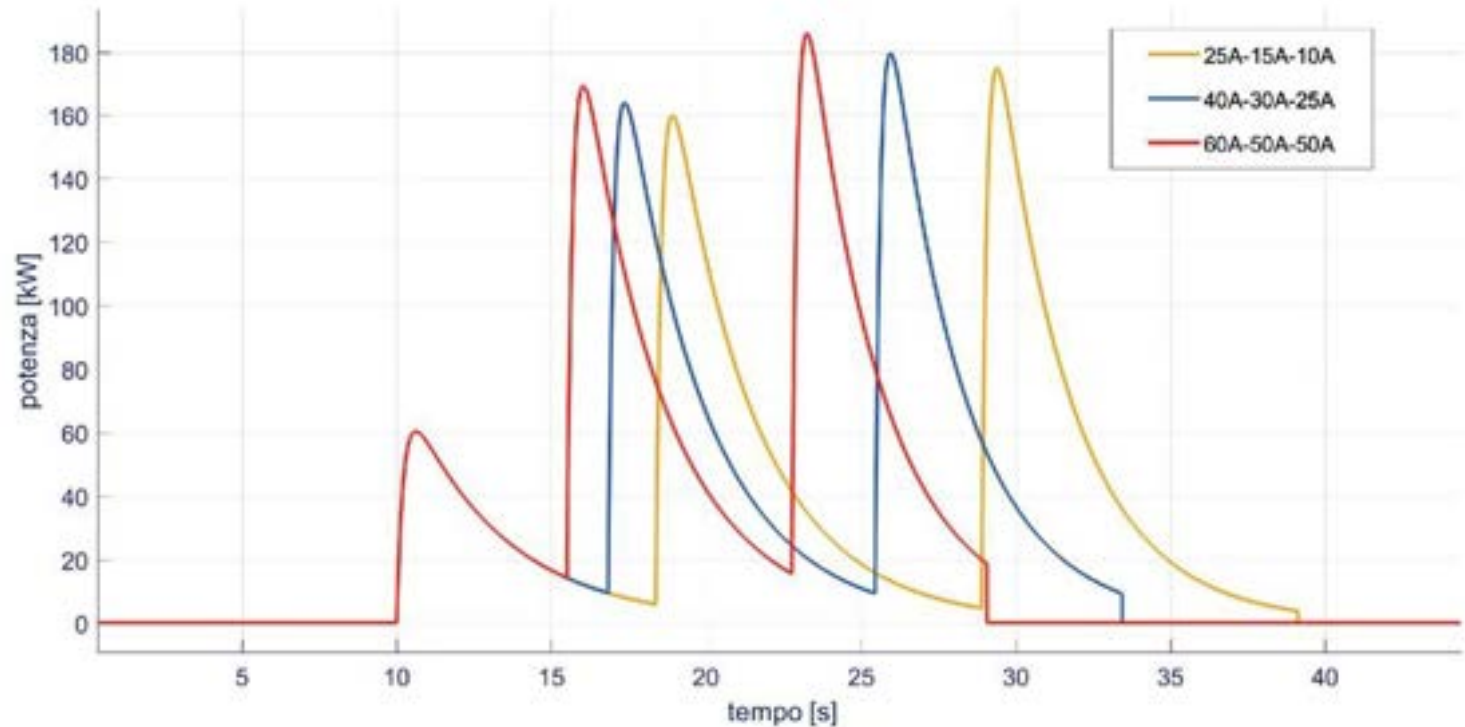

# Il sistema di accumulo di bordo

IL SISTEMA DI ACCUMULO MISTO  
SOSTITUISCE QUELLO TRADIZIONALE  
ALL'INTERNO DEL SUO CASSONE



BATTERIE

SUPERCONDENSATORI

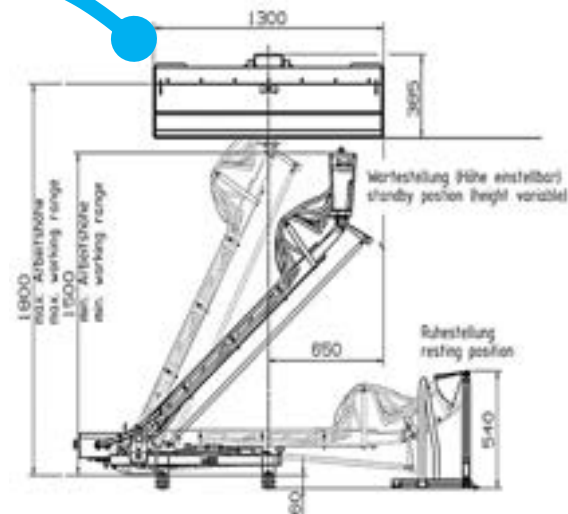

PANTOGRAFO SCHUNK  
1000V / 1000 A MAX

# GRAZIE!

[fernando.ortenzi@enea.it](mailto:fernando.ortenzi@enea.it)

