



**Nucleare da fissione  
Studi sul nuovo nucleare e partecipazione ad  
accordi internazionali**

*Linea Progettuale 3  
Reattori di IV Generazione*

*Risultati Conseguiti*

*Mariano Tarantino, Pietro Agostini*  
(mariano.tarantino@enea.it) (pietro.agostini@enea.it)

**Workshop PAR2011, ENEA, Roma, 28 Novembre 2012**

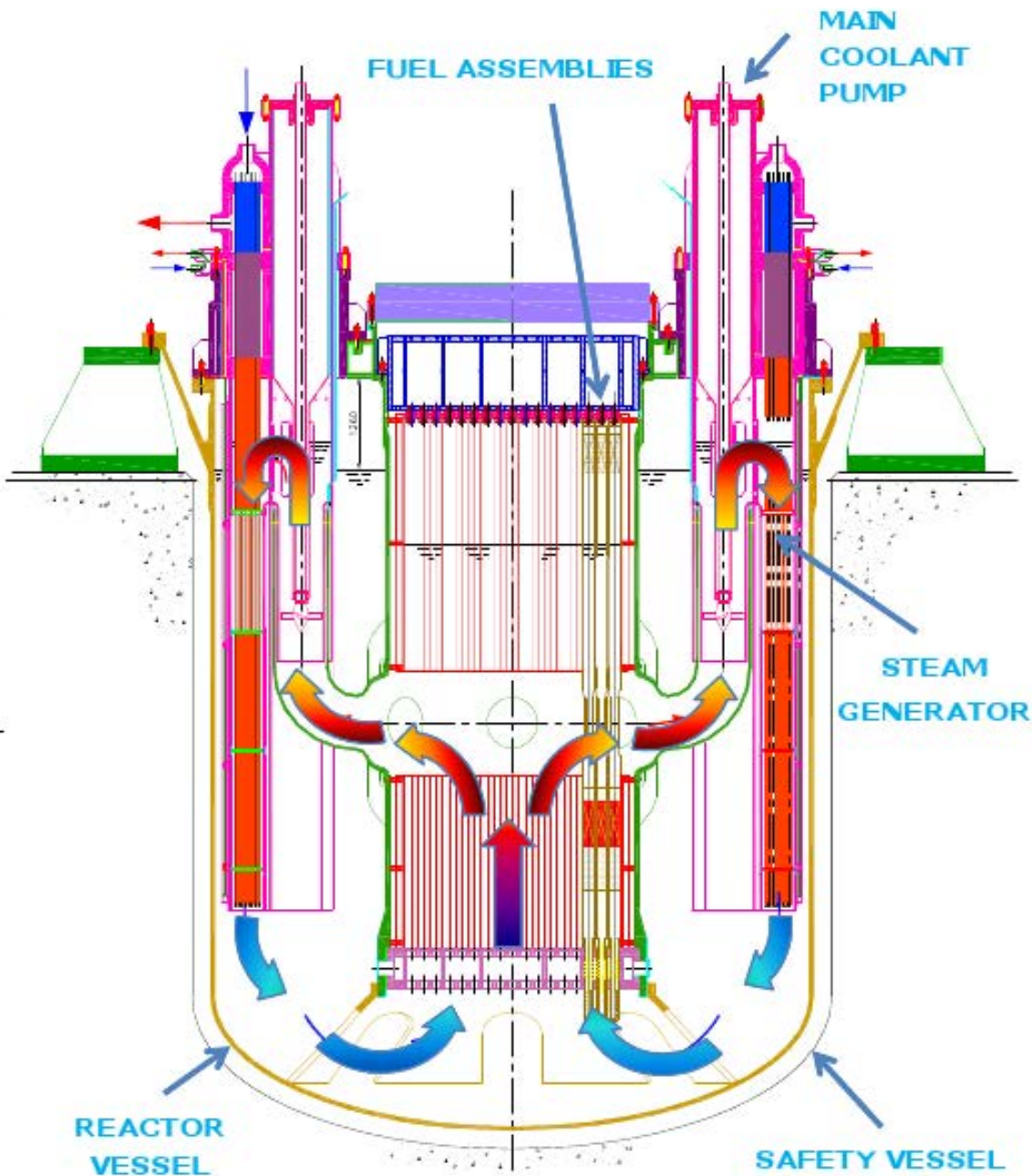

## LFR Development

- ④ International and national frame
- ④ Conceptualization & System Design
- ④ Structural Material and Manufacturing studies
- ④ Thermal-Hydraulic
- ④ Safety Assessment

# European frame

- ✓ **ESNII** supports the erection of GEN IV reactors in Europe
- ✓ **ASTRID** (SFR) will be built in France and can rely on French national contributions
- ✓ LFR Technology Pilot Plant (**MYRRHA**) will be built in Belgium and can rely on Belgian national contribution. Italian technology is also involved
- ✓ The **LFR Demonstrator** and the **GFR Demonstrator** will be hosted by East Europe countries relying on regional EU funds for R&D infrastructures:
  - ✓ **Romania** offered to host the LFR demonstrator (**ALFRED**) based on Italian technology
  - ✓ **Czech Republic** offered to host the GFR demonstrator (**ALLEGRO**) based on alternative French technology
- ✓ Only one demonstrator among ALFRED and ALLEGRO will be endorsed by ESNII

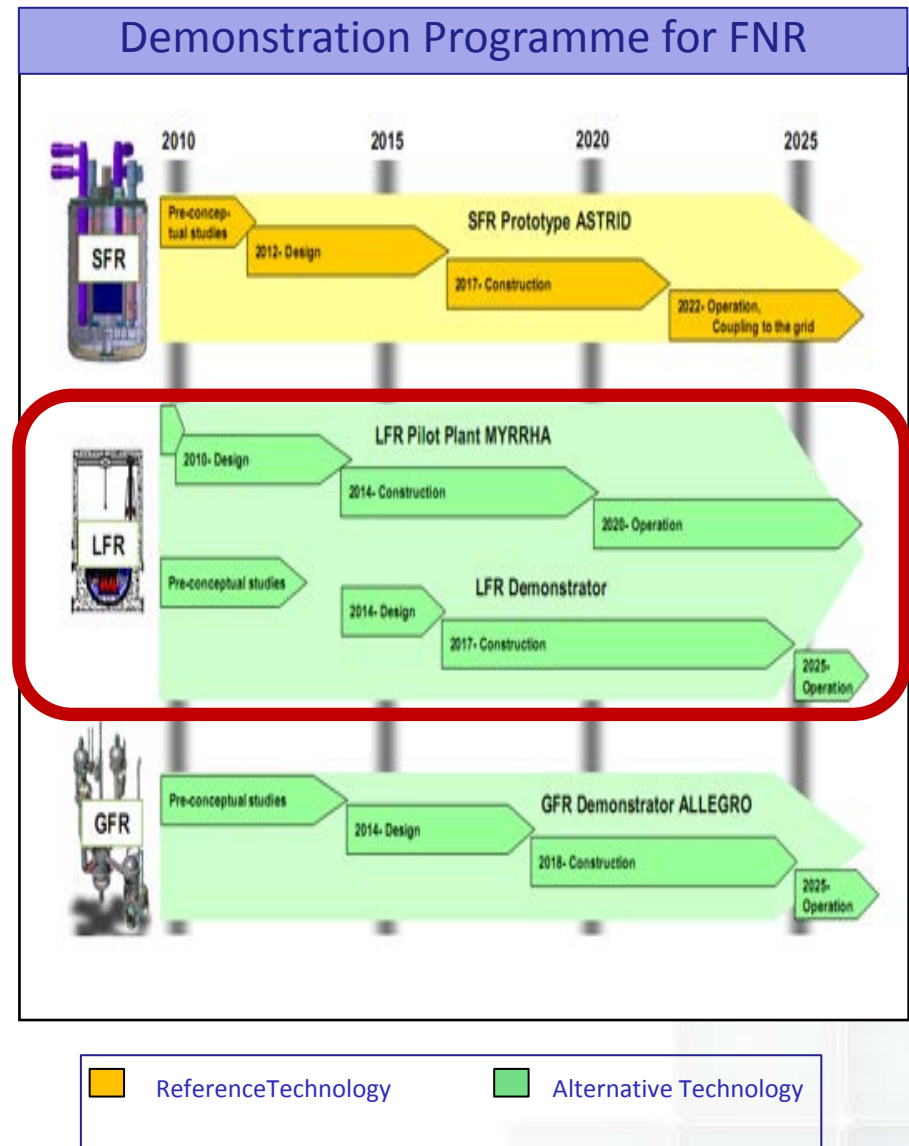

# Italian strategy

The Italian R&D activities in HLM technologies started in the late 90s' by the ADS Project (ENEA, ANSALDO, INFN) aimed to transmute the long living radio-waste (minor actinides) and use them for power production by employment of fast neutrons.

In the GEN-IV scenario, the Italian system (ENEA + UNIs + Industries) is strongly involved in LFR technology.

Several Italian institutions are involved in MYRRHA:

- ✓ ENEA in core design and in experimental TH
- ✓ ANSALDO in system design

The Italian system is mainly involved in ALFRED:

- ✓ ENEA on core design and TH & Safety assessment
- ✓ ANSALDO is the main designer of system and components
- ✓ MERIVUS (TECNOMECC group) is the designer of main components
- ✓ FN contributes in term of components development
- ✓ CSM contributes to the development of materials technologies
- ✓ CIRTEN contributes on numerical simulations and technologies development

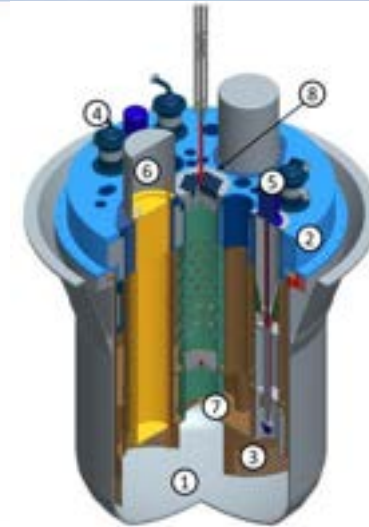

MYRRHA  
LFR Technology  
Pilot Project  
Belgium

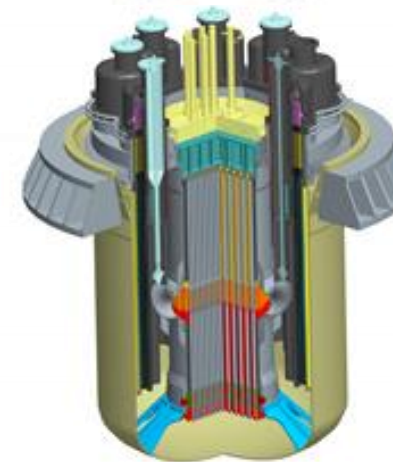

ALFRED  
LFR Demonstrator  
Romania

- ❖ ENEA, by means of the AdP funds (3M€/y) and 7 FP EC funds (3M€/y), coordinates the Italian R&D efforts for LFR technology, mainly for ALFRED
- ❖ The perspective is to get 85% of the design and licensing from EU cohesion funds through Romanian Government, and then 85% funds for the erection of ALFRED

# Employed Resource

- @ **Main Partners : CIRTEN, FN, UNITV, CSM SpA**
  
- @ **35 Researcher, Technologist, Technician of ENEA involved into the project**
  
- @ **40 Deliverable Issued**
  
- @ **Synergies:**
  - @ **FP7 EC Project: THINS**
  - @ **FP7 EC Project: LEADER**
  - @ **FP7 EC Project: SEARCH**
  - @ **FP7 EC Project: MAXSIMA**
  - @ **FP7 EC Project: MATTER**
  - @ **FP7 EC Project: GETMAT**

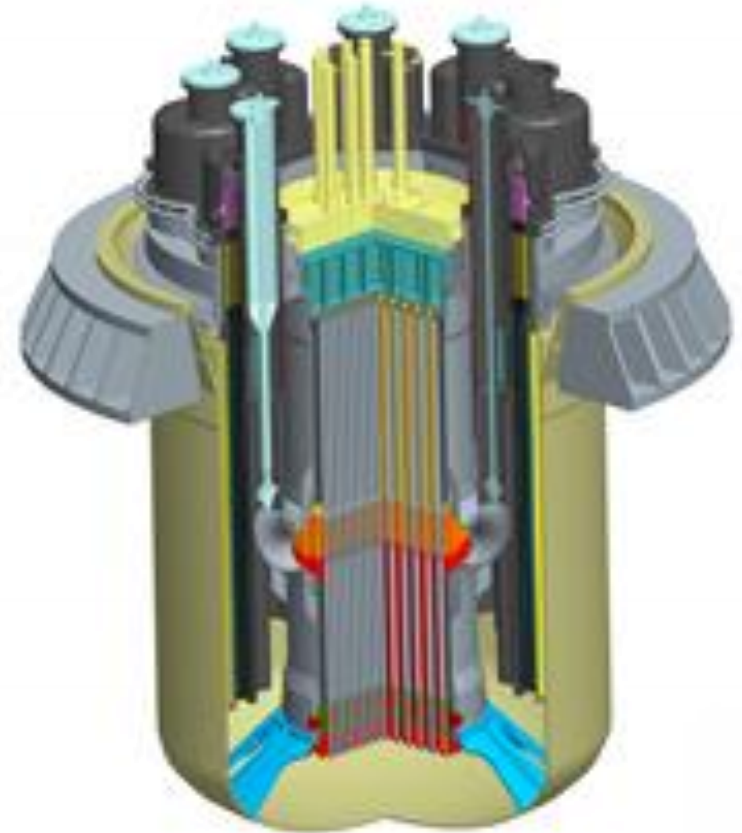

# Conceptualization and System Design

- ✓ Validation of the GPT (**Generalized Perturbation Theory**) methodology implemented in the **ERANOS** neutronic calculation code
- ✓ **FEM-LCORE** code development
- ✓ Validation of thermal-hydraulic of **FRENETIC** code
- ✓ **DEMO** Conceptualisation

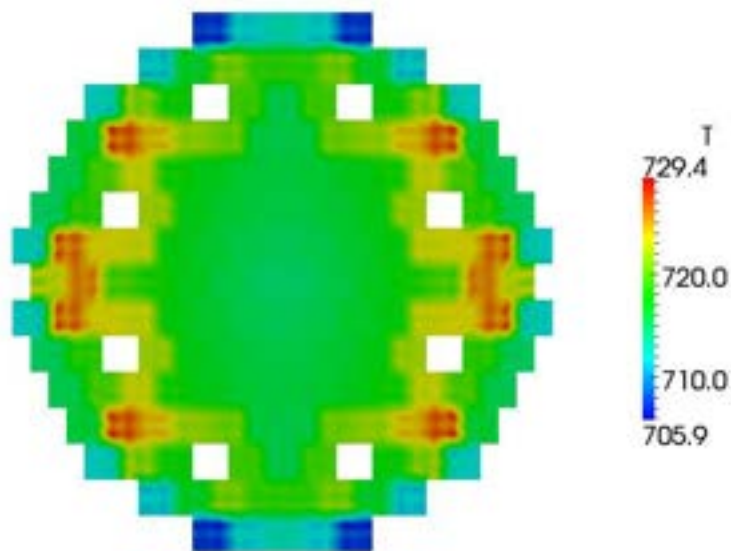

Parametro	DEMO	AFRODITE
Potenza del nocciolo [MW]	300	300
Altezza attiva [cm]	65	65
Velocità del refrigerante nei sottocanali [m/s]	3.0	1.5
Passo del reticolo di barrette [mm]	8.71	14.10
Diametro della barretta [mm]	6.00	11.60
Diametro del foro nella pastiglia [mm]	1.72	3.00
Raggio della pastiglia di combustibile [mm]	2.55	4.95
Spessore dell'intercapedine [mm]	0.10	0.15
Spessore della guaina [mm]	0.35	0.70
Numero di barrette per elemento	28 x 28 – 6 x 6 – 4	16 x 16 – 4 x 4
Numero di elementi	24	73
Raggio equivalente del nocciolo [cm]	76.5	120
Inventario di combustibile nel nocciolo [t]	2.21	8.36
Arricchimento medio del combustibile [%]	32	(atteso) 26
Potenza lineare massima [kW/m]	36.2	34.84
Burn-up di picco [MWd/kg]	100	100

# Conceptualization and System Design

- The development of neutronic models of simple experimental systems, such as TAPIRO, constitutes **the basis to develop well-designed experience and calibration methodology in support of LFR and ADS activities.**
- To fulfill this scope, a very detailed **TAPIRO model has been implemented as MCNPX input deck to reproduce** the late experimental configurations on which the measurements have been performed.
- The model outcomes in terms of criticality analysis, neutron flux intensity, neutron spectra, and reaction rates in the irradiation channels have been compared with the late measurements finding an **overall good agreement.**

Reinterpretation of the Late SCK-CEN/ENEA Experimental Neutronic Campaign on TAPIRO Fast Reactor with MCNPX

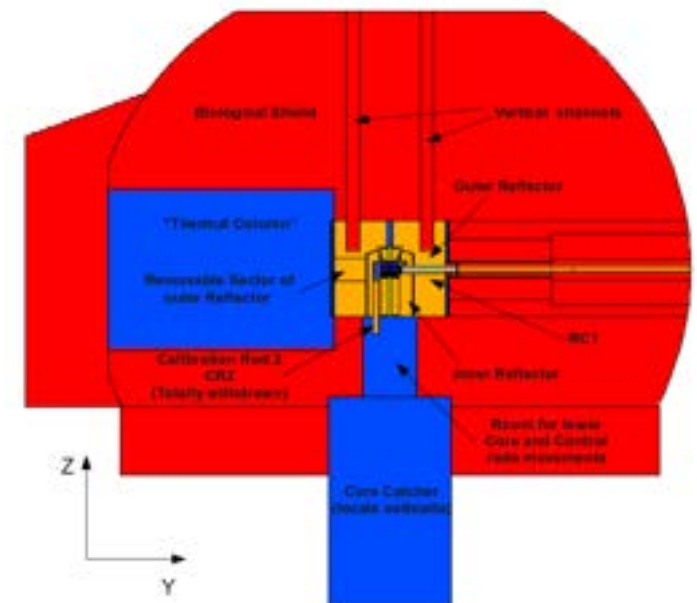

## 15-15 Ti mod (Si) Procurement and Preliminary Characterization



In Europe 15-15Ti CW-20% steels is the reference cladding material. More than **10,000 pins** with oxide fuel and peak cladding temperature up to 650°C have reached dose values of 100 dpa and **1000 pins** have exceeded 125 dpa with a max value of 148 dpa for an experimental sub-assembly (**217 pins**)

$0,08 \leq C \leq 0,10$   
 $14,0 \leq Cr \leq 16,0$   
 $14,0 \leq Ni \leq 16,0$   
 $1,0 \leq Mn \leq 2,0$   
 $1,3 \leq Mo \leq 1,7$   
 $0,30 \leq Ti \leq 0,5$   
 $0,70 \leq Si \leq 0,9$   
 $0,003 \leq B \leq 0,008$   
 $0,03 \leq P \leq 0,05$   
 $N \leq 0,015$

Optimal 14,5  
Optimal 15,5

Optimal  $(Ti/4 C) \geq 1,0$   
Optimal 0,85  
Optimal  $\geq 0,004$   
Optimal 0,045

### Grid-to-Rod Fre

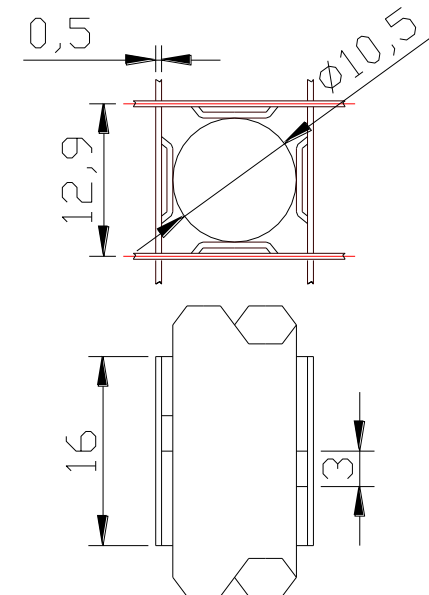
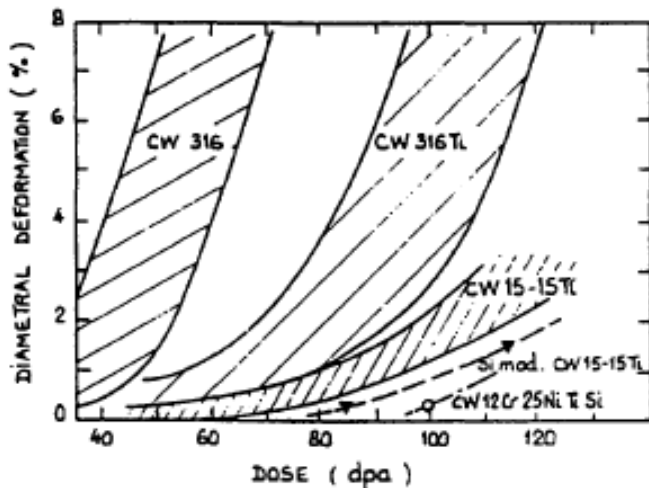



## Coating characterization for structural material

Planned Test:

1. Flowing Pb corrosion tests
2. Stagnant Pb corrosion tests
3. Tensile Tests
4. Bending Tests
5. Creep-Rupture Tests (in Lead)
6. Fretting Tests (grid-to-rod fretting)
7. Stagnant corrosion tests of heating elements

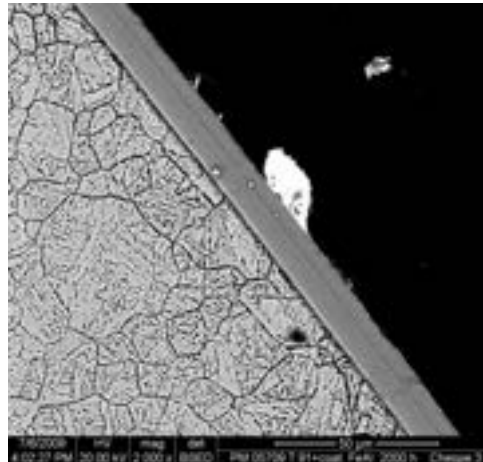

**FE-SEM+EDS:  
Morphology & composition**

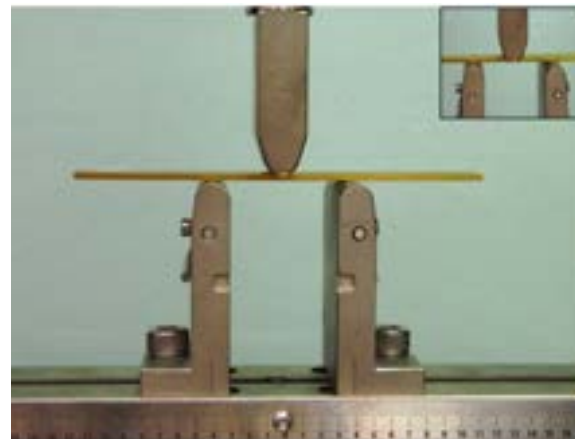

**Three point *bending* test:  
film adhesion**

## Manufacturing test for the LFR fuel element development

1. Preliminary evaluation about the hexagonal closed fuel element assembling
2. Manufacturing test about the joining of vented open square fuel element rod and support grid

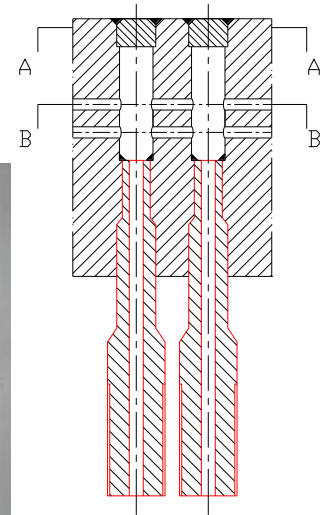

## Detonation Spray Procurement

The fully computer controlled detonation spraying was successfully applied for different powders: metals (aluminum, copper, iron, nickel, cobalt, molybdenum, etc.), alloys (steel, cast iron, nickel-chrome, etc.), ceramics (alumina, zirconium dioxide, chrome and titanium oxides, etc.), cermets (carbides of tungsten, chromium, titanium with a binder)



# Thermal-Hydraulic

Non-intrusive induction-based flow meter for Lead

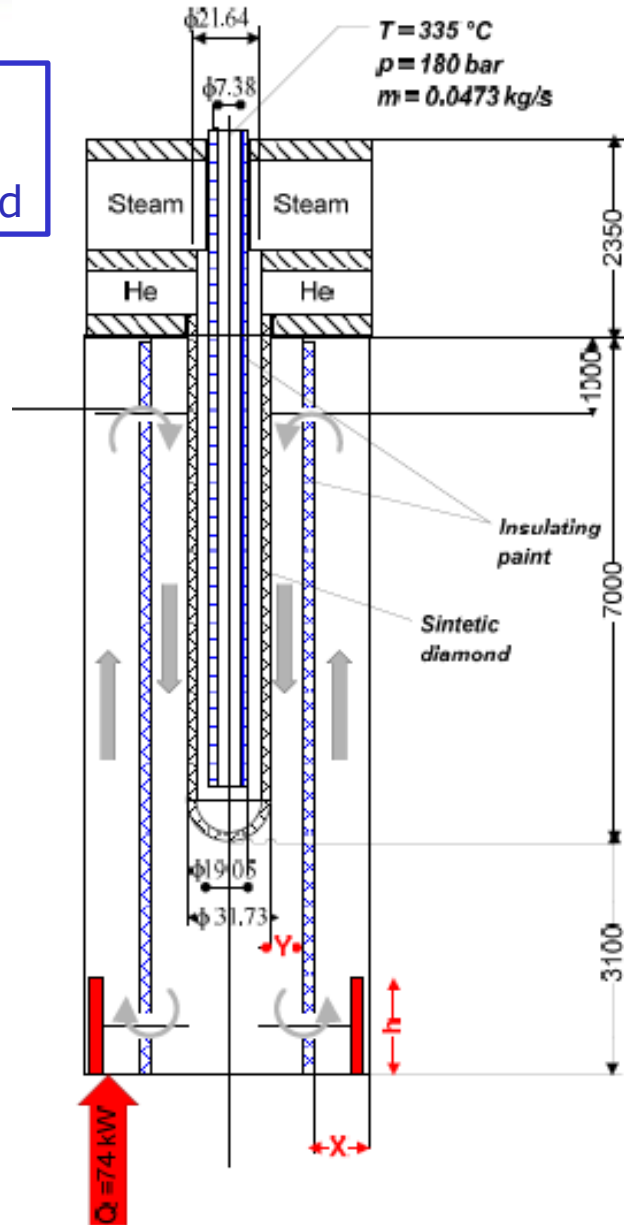
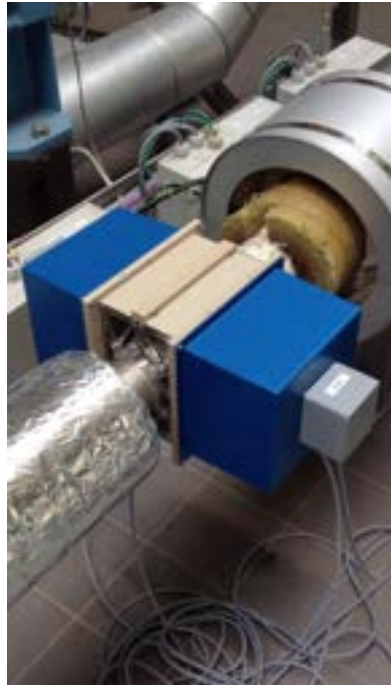

Assessment of the SGBT by RELAP-5

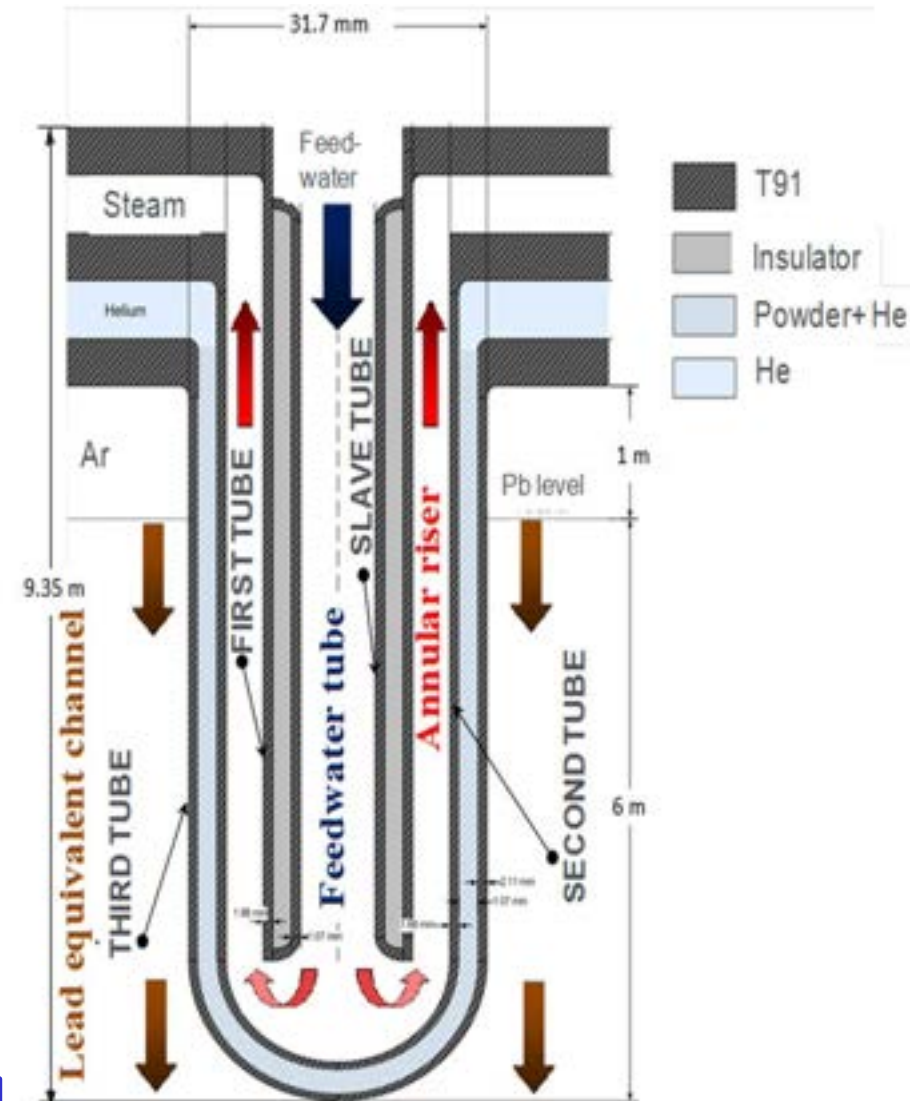

Heavy liquid metal - pressurized water cooled tube

# Thermal-Hydraulic

## Post Test Analysis of ICE Tests

## Technical Specification for the DHR qualification

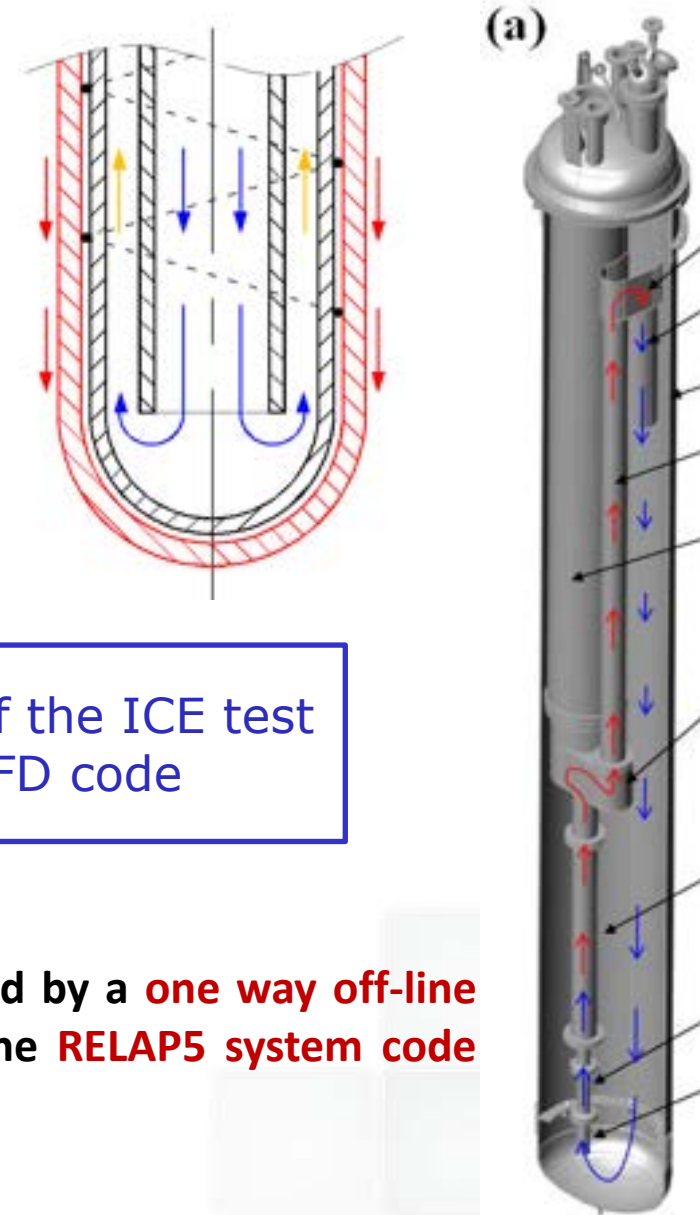
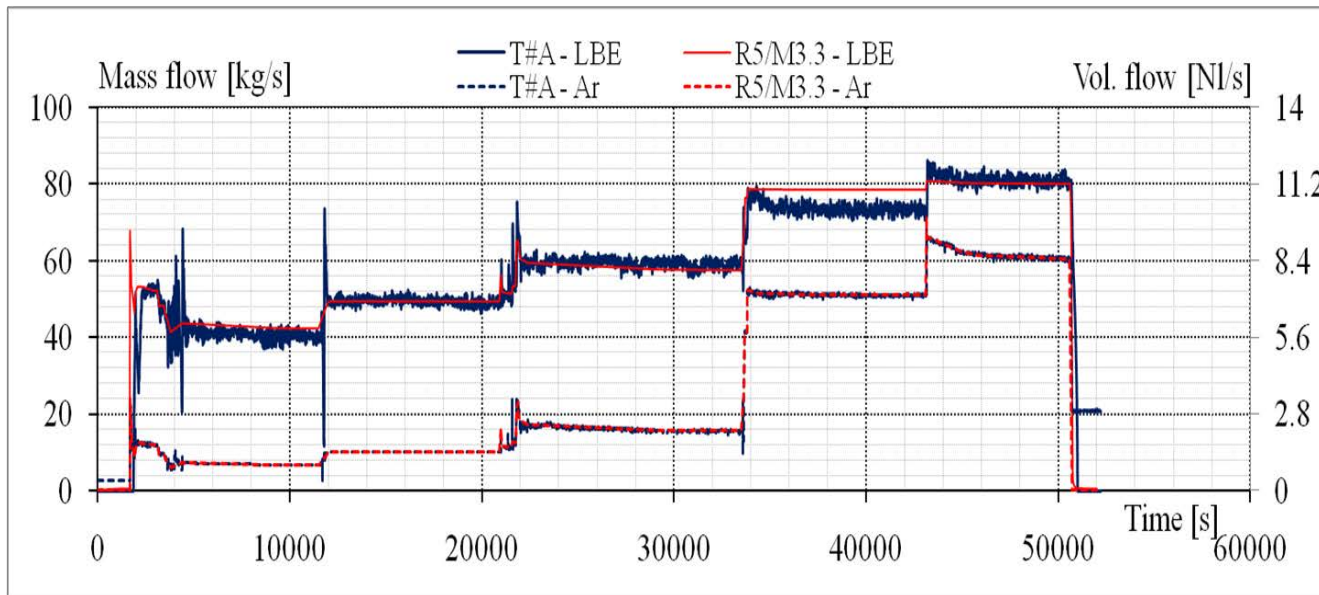

Numerical analysis of the thermal-hydraulic behavior of the ICE test section by the coupling of a system code and a CFD code

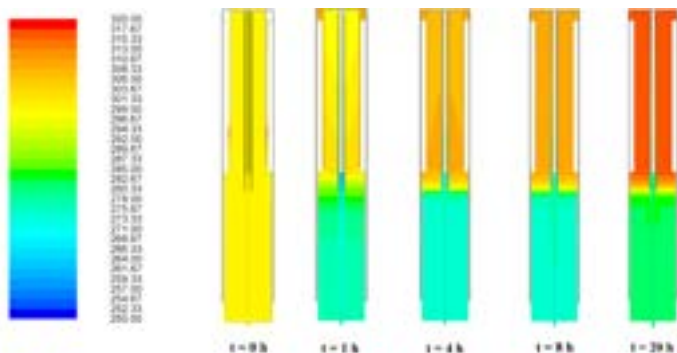

The analysis was performed by a **one way off-line coupled model** between the **RELAP5 system code** and the **CFD Fluent code**.

# Thermal-Hydraulic

## CIRCE experimental set-up design and test matrix definition

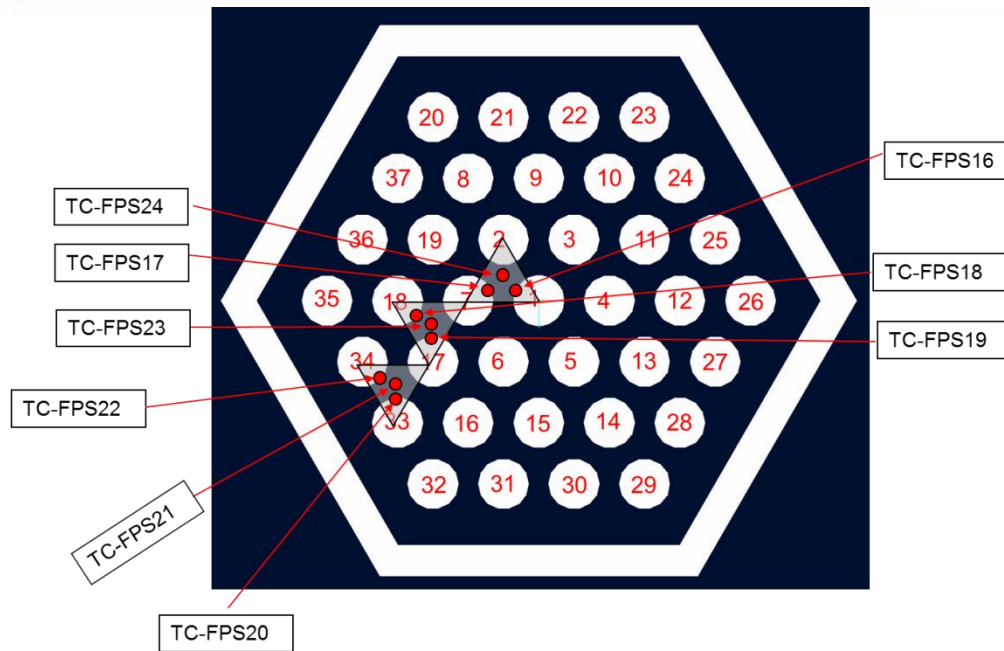

- ➔ HTC measurement in fuel bundle under forced and natural circulation

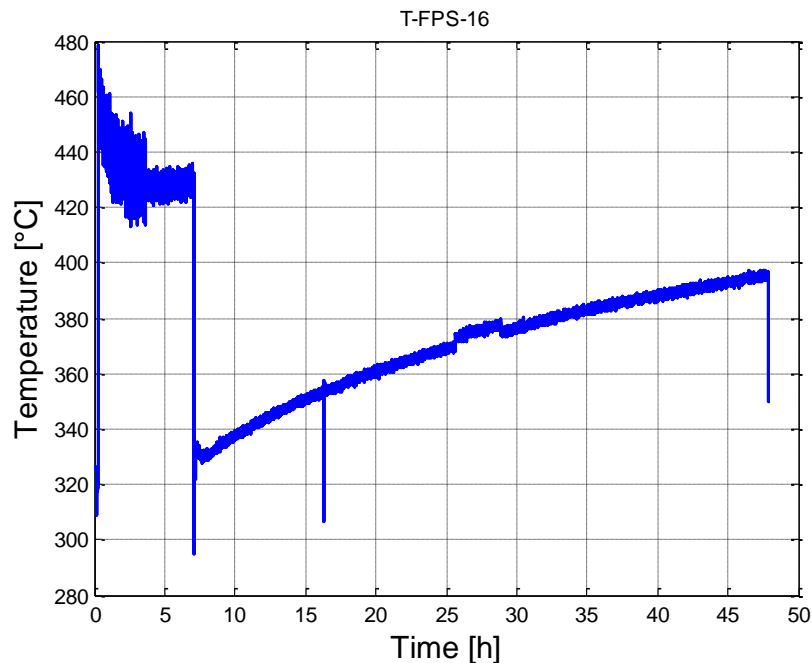

# Thermal-Hydraulic

- Analysis by RELAP5/Mod3.3 system code to characterize the performance of a wire spaced fuel bundle relevant for MYRRHA facility (i.e. heat exchange and pressure drop) in shutdown conditions and providing data for code validation.
- First application, to a simplified representation of NACIE facility, of the coupling between the RELAP5 thermal-hydraulic system code and the CFD Fluent commercial code

## Pre-test analysis of thermal-hydraulic behaviour of the NACIE facility for the characterization of a fuel pin bundle

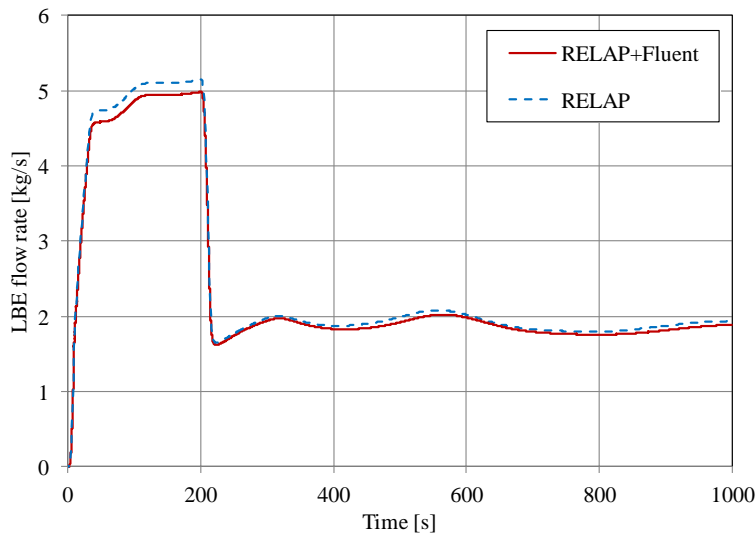
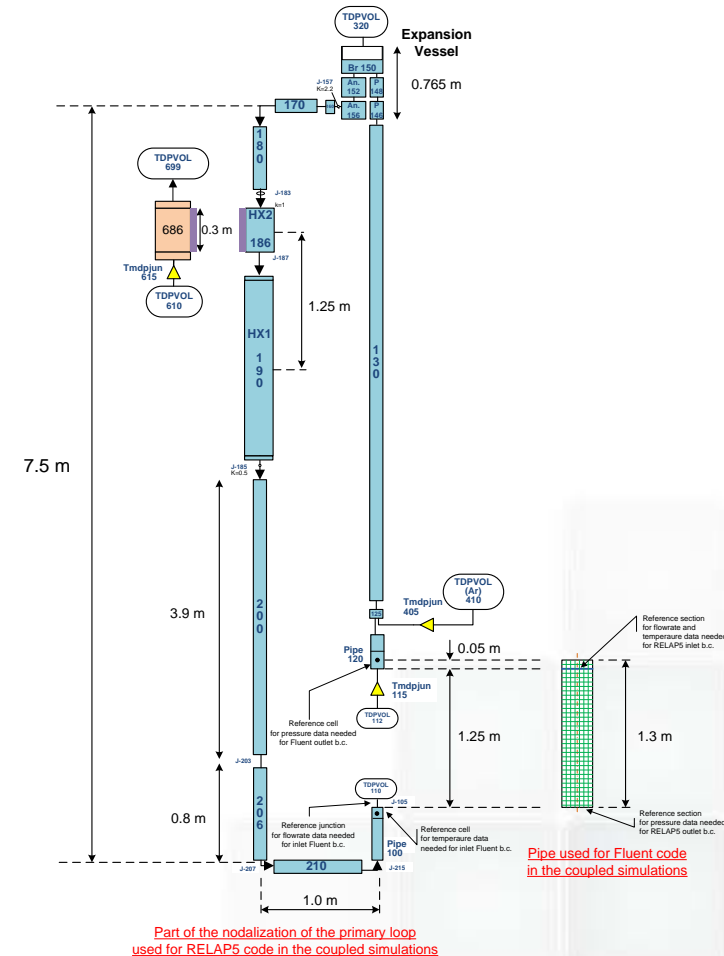

# Thermal-Hydraulic



HELENA facility Procurement





# Safety Assessment

Conceptual design and feasibility study of an experimental apparatus for the characterization of the release and migration of fission products in a LFR

The apparatus consists of a test section made of two rooms (internal and external) and by two circuits: gas and lead side. It allows to operate from ambient pressure up to pressures of 80 bar the gas side, and temperatures up to 700 ° C.

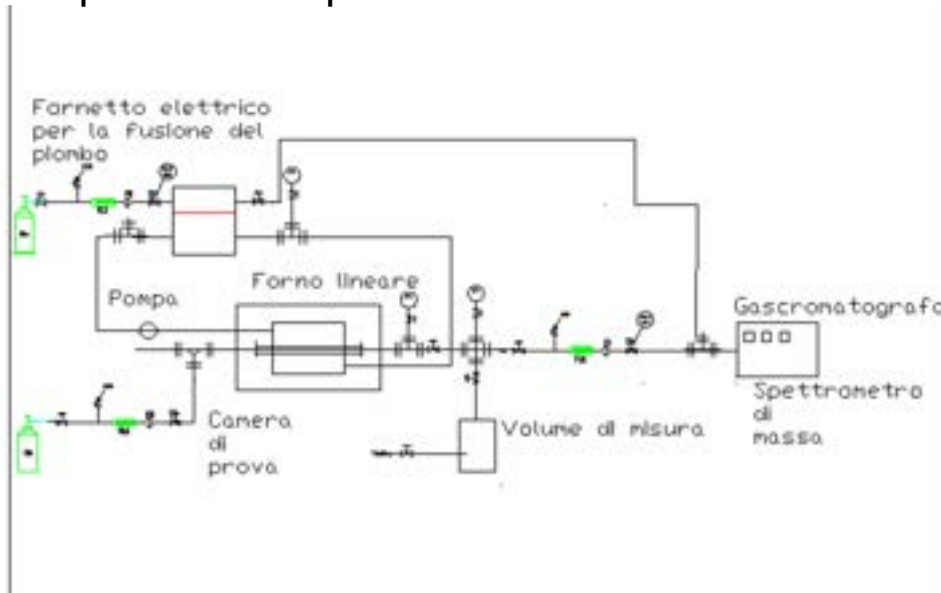

Methodology for the evaluation of fission gas release in LFR

Due to the complexity of FGR mechanism and of the evaluation of related quantities, use of **advanced computational tools cannot be avoided.**

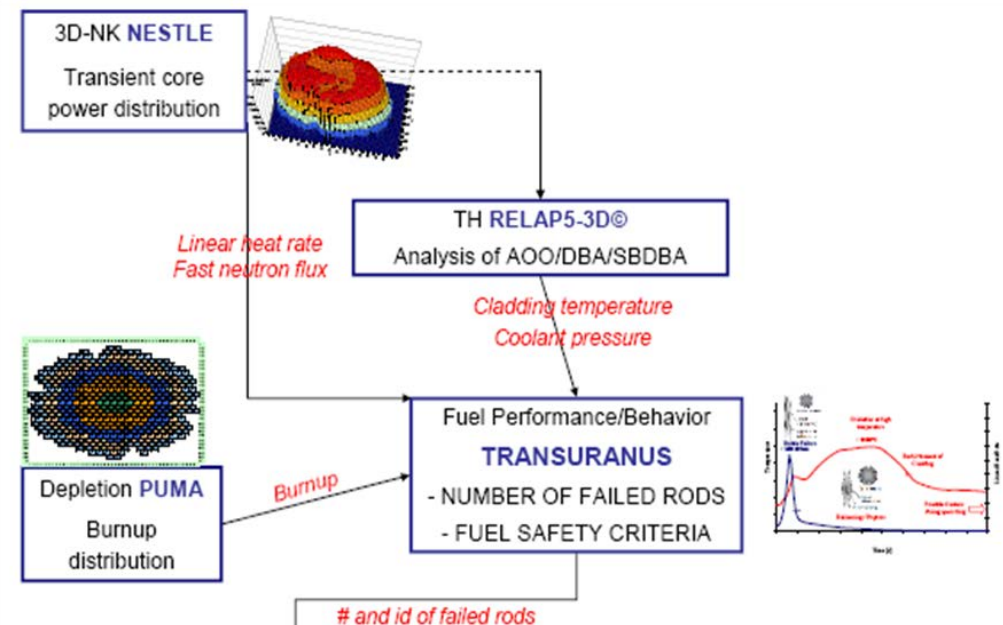

## Loss of core integrity in a LFR system: models and preliminary numerical analysis

### Transient Results

- An ULOF transient is calculated with SIMMER-III in order to verify the correct operability of the modeling. The results are compared with those obtained by RELAP5

Comparison in fuel particle concentration at 300 s (fuel porosity of 5% and 10%)

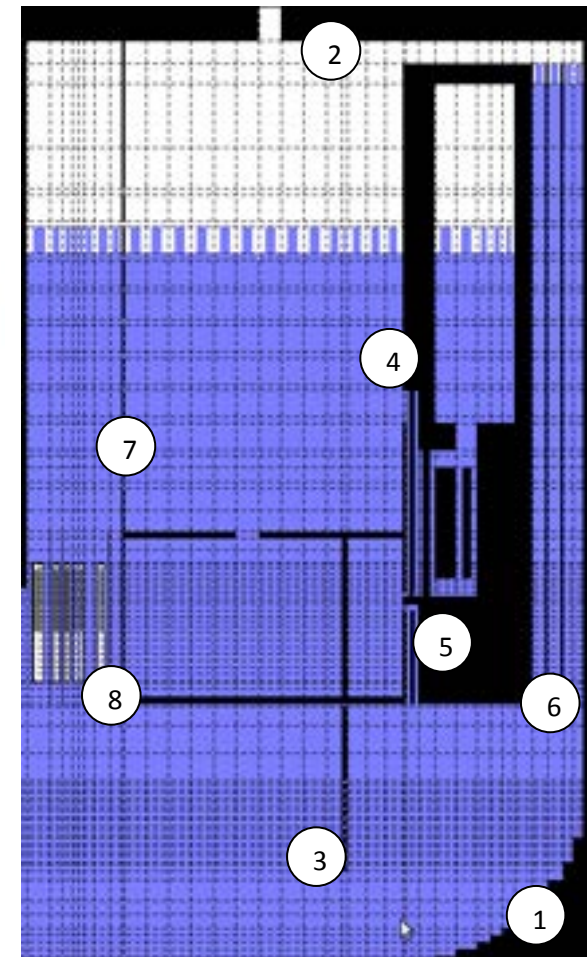
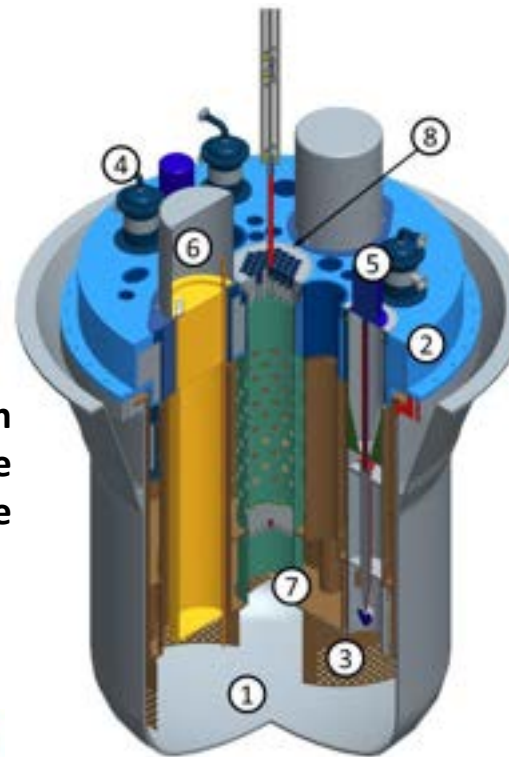
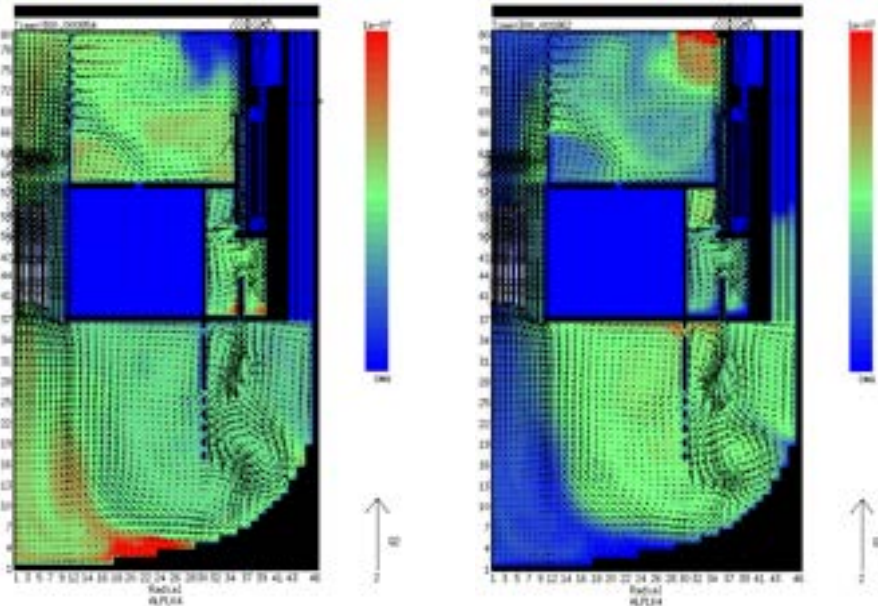

- The fuel dispersion is evaluated in the case of forced circulation and in the case of natural circulation
- An important aspect to be taken into account is the relative density of the fuel and the LBE because while the coolant density depends only on temperature, the fuel density depends also on the fuel porosity that increase with the irradiation from 5% to 10%

## FA flow blockage in a LFR reactor core: CFD modeling and preliminary analysis

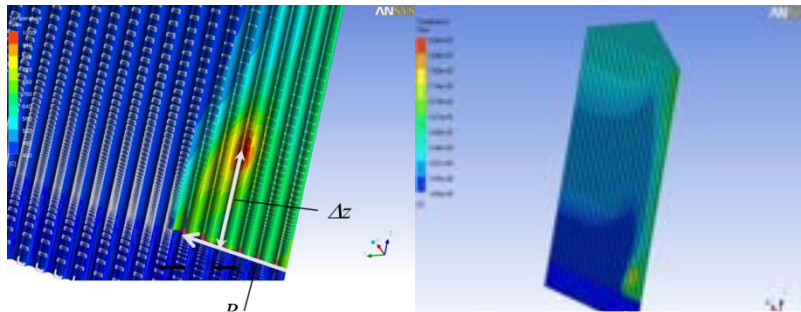

ALFRED FA	Re	$\beta$	Nsub Blocked	$T_{max,clad}$ [°C]
BS	$9.3 \cdot 10^4$	Single subch	1	528
B2	$9.3 \cdot 10^4$	0.20	88	854
B4	$9.3 \cdot 10^4$	0.40	176	1025

ELSY FA	$\beta$	Blockage position		$T_{max,clad}$ [°C]
AL1	Single subch	Central	1	526
AL4	0.10	Central	1	611
AL7	0.20	Central	25	750-800
BC4DP0	0.40	Central	51	995
AL10	0.50	Central	64	1300-1539

A *comparison* has been carried out between a *square open (ELSY)* and a *wrapped hexagonal (ALFRED)* FA

## Freezing of the LFR primary pool: CFD modeling and preliminary analysis

Methodology:

the single-fluid single-phase approach has been chosen;

The basic idea and the main approximation is to consider the freezing process occurring in a small temperature range  $\Delta T_{melt} \sim 1-2$  °C (*Freezing Temperature Window*) by setting a temperature dependent  $c_p$ .

The second step is to introduce *a force which simulates the growing resistance* of the fluid during solidification

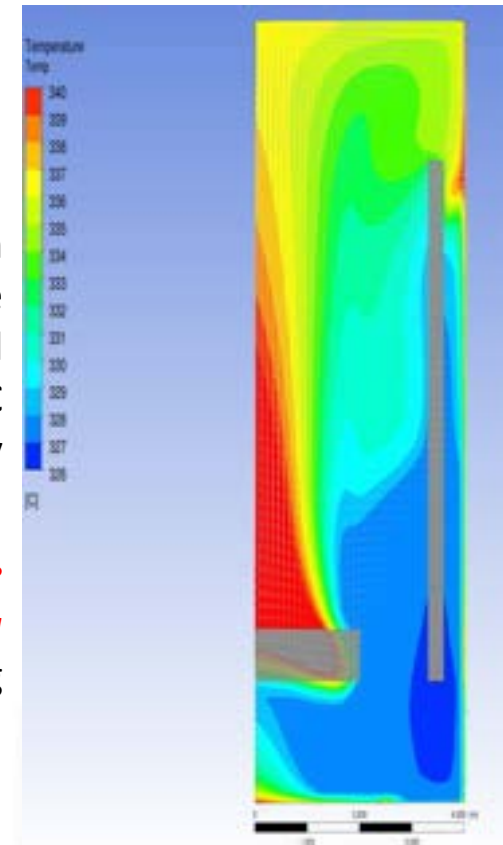

## PRELIMINARY ASSESSMENT OF THE FLUID-STRUCTURE INTERACTION EFFECTS IN LFR

## Evaluation of a molten salt process for recovery of actinides from MOX fuel

**NPP behaviour in beyond design earthquake condition is yet acceptable ?**

**What's about LFR?**

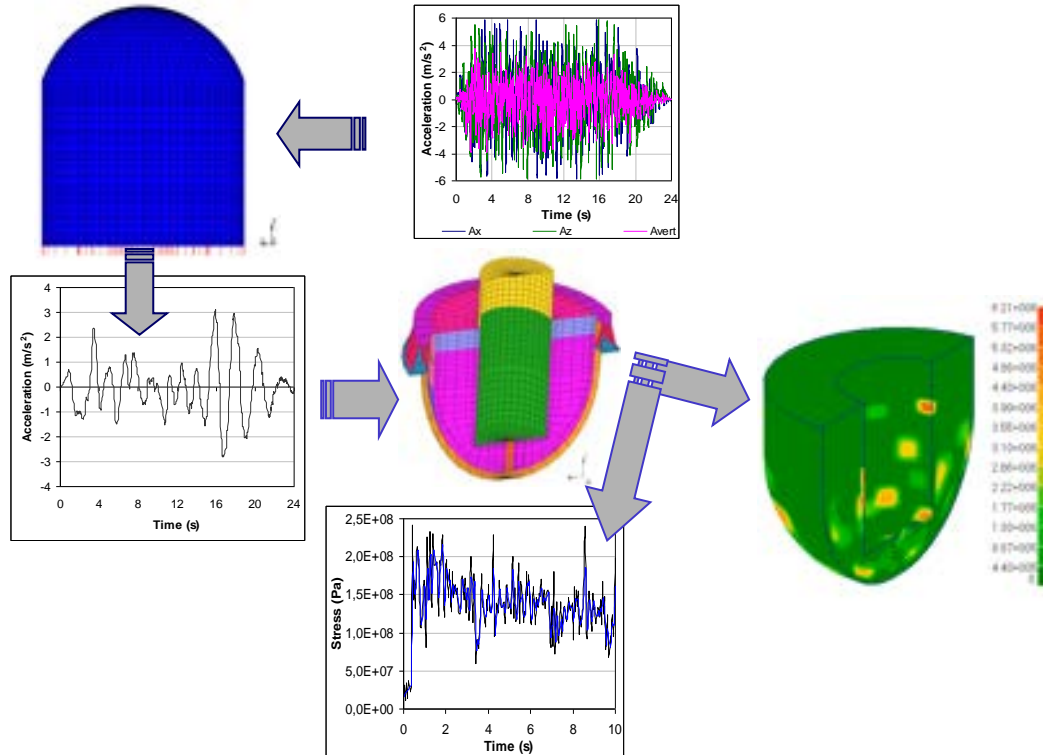

The pyrometallurgical processes have been analyzed ( for MOX fuel reduction)

In the meantime, the set-up of a plant for experiments in “cold” conditions - termed Pyrel III – has been completed.



# Outlook: Program Agreement 2009-2011

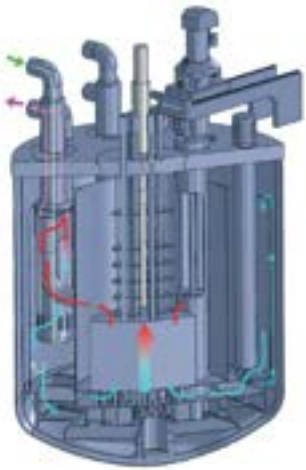

**SFR Prototype (ASTRID)**

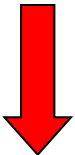

- Design and Implementation of infrastructures and laboratories supporting the LFR and SFR development.
- Development and Qualification of prototypical components and systems



- Development and Verification & Validation of numerical tools aiming to support the design of LFR, SFR e GFR



**LFR Pilot Plant (MYRRHA)**

**LFR Demonstrator (ALFRED)**

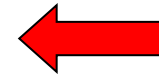

**GFR Demonstrator (ALLEGRO)**



- DEMO-LFR Conceptualization
- Structural material Qualification